

Service Manual Etnyre Chipspreader

7050996

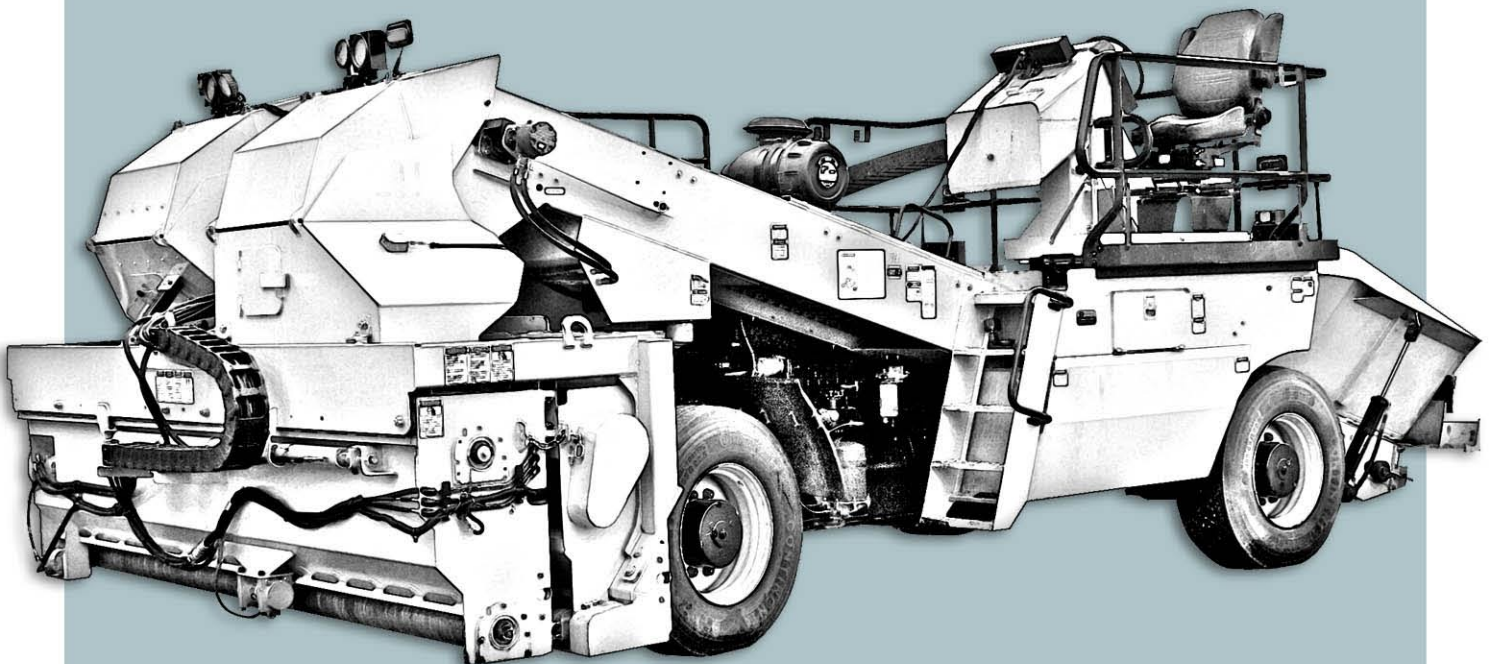

330-783-2000
Parts@ktsdi.com
Youngstown, OH USA

KESSLER+CO

Edition 03/2006

Table of contents

- 1** Important remarks
- 2** Lubrication intervals and maintenance instructions
- 3** General instructions for correct assembly and disassembly
Service tools
- 4** Assembly drive assembly
- 5** Assembly hub assembly
- 6** Assembly planetary gear drive
- 7** Assembly service brake
- 8** Assembly parking brake

Important remarks

Important remarks

For safety reasons , the operator should verify and service at regular intervals all of the bolted assemblies and all of the important safety locks such as :

- Wheel nuts
- Nuts of axle mounting bolts
- Bolts on the steering components and the brake system parts ; if the screws are tightable , the Loctite contact breaks loose and remounting is necessary .
- Corrosion on the carrier elements (such as the axle spindle) is not acceptable for operational safety reasons .
- Verify seals , oil levels and lubrication at regular intervals .

Brakes

- Inspect brake lining and brake drum / brake disk regularly as well as wear of brake system parts .
- Inspect the free movement of brake system rods .
- In case of signs of excessive heating , consult a brake specialist or the manufacturer .

Lubrication intervals and maintenance instructions

General lubrication instructions

Lubrication points see sheet 2.2 resp. installation drawing .

Lubricants see sheet 2.3

Fill levels Are checked at the level control plugs .

Oil change

Place the vehicle in a horizontal position . Draining of the oil is to be accomplished only in warm condition . Clean all lubrication points before opening them . Open the drain holes on the carrier assembly , on the wheel assemblies , and if present , on the interaxle differential and drop gear housing . On the hub assemblies , the drain plug should be turned downward .

Oil draining

Replacement of the oil draining plugs

Remove the oil filler plug as well as the oil level control plug on the carrier assembly , on the wheel assembly , and , if present , on the interaxle differential and drop gear housing . (see sheet 2.2 → lubrication points) .

Oil filling

Check the oil level at the oil level plug hole (Overflow control) . Wait a few minutes . If the oil level falls , add oil until the level remains constant .

Clean the grease nipples before lubrication .

Lubrication intervals see sheet 2.3

Important !

On the axles with self locking differentials , a noise is produced if normal oils are used . In case of abnormal noises and in case of operation under bumpy conditions , use gear oil EP with additives of the „ Limited Slip „ type conforming to specification M 2C - 104 A .

In case of prolonged non - operation of the vehicle , it is recommended to start - up and operate all of the parts of the gear train every 6 months . For this purpose , maintain the proper oil level which also protects the axle against water intrusion .

The surfaces of the brake areas are to be preserved in humid locations . On start - up , a break - in of the braking system by intermittent operation is indispensable .

Lubrication points

The binding lubrication points has to be taken from the according installation drawing of the axle .

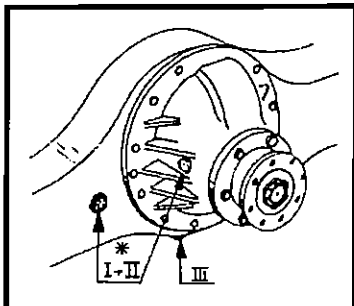

Single drive assembly

* The position is dependent from the respective axle version.

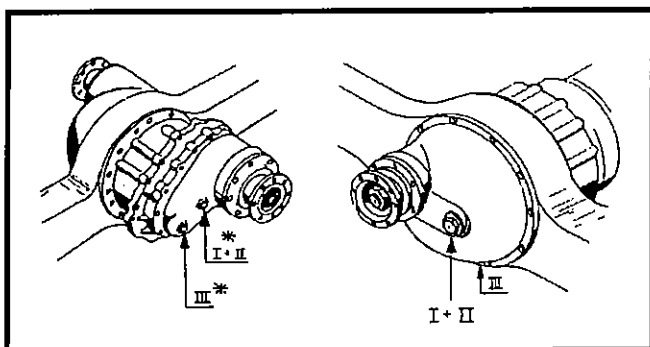

Drive assembly with throughdrive
Version with interaxle differential
fill 1,5 litre oil at I + II * for first - time
filling and for refilling !

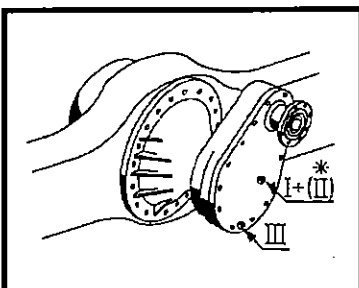

Drop gear D 51 / D 108

* II only at version with separately oil space .

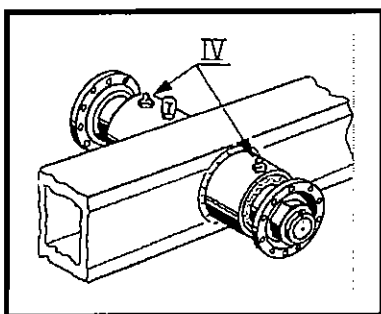

Cardan shaft intermediate bearing

I = Oil fill plug
II = Oil level control plug

III = Oil drain plug
IV = Grease nipple

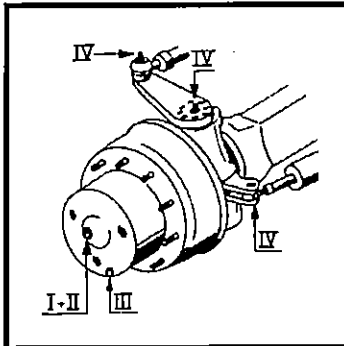
Lubrication points

Hub assembly with planetary gear drive

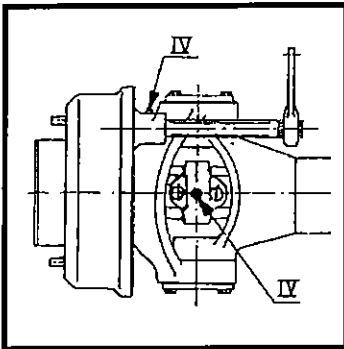
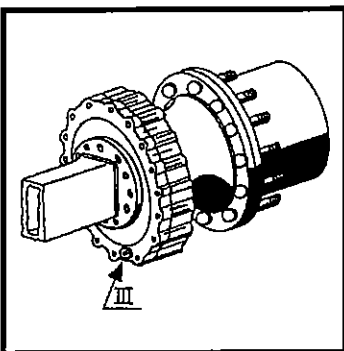
Lubrication points at universal joint and brake shaft .
(if not maintenance - free)

Hub assembly with wet disk brake

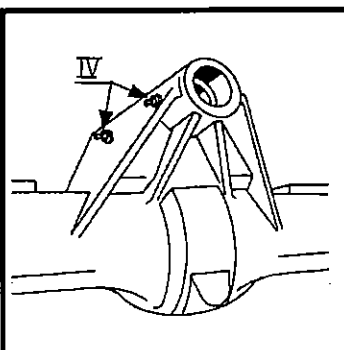

Tumbler bearing

I = Oil fill plug
II = Oil level control plug

III = Oil drain plug
IV = Grease nipple

Lubricants and lubrication intervals

Lubrication point	Lubricant	Remarks	Lubrication intervals 1.)				
			after 100Bh 1000Km	every 500Bh 5000Km	every 1000Bh 10000Km	min. 1x Year	min. 1x in 2 Years
Drive assembly	Hypoid – gear oil per MIL-L – 2105 B / API GL 5 Hypoid – gear oil in multi – range characteristic per MIL-L – 2105 C / D / API GL 5 SAE 90 or multi grade oils for normal external temperature SAE 75 W – 90 ; SAE 75 W – 85 for external temperature lower – 10° C SAE 140 or multi grade oils for external temperature over + 30° C	Oilchange	⊕		⊕	⊕	
Wheel hub planetary gear drive		Check oil level at control points monthly	⊕		⊕	⊕	
Interaxle differential		⊕		⊕	⊕		
Drop gear / Gear boxes		⊕		⊕	⊕		
Wheel bearing oil lubricated		⊕		⊕	⊕		
Multi disk parking brake	Hydraulicoil ISO VG 32		⊕		⊕	⊕	
Steering knuckle bearing	Multi – use grease lithium saponified groove penetration per NLGI 2 f. e. Fuchs Renolit MP 150		⊕	⊕			
Steering knuckle bearing		maintenance reduced			⊕	⊕	
Universal joint		if provided for	⊕	⊕			
Track rod		if provided for	⊕	⊕			
Steering cylinder -ball head / -spherical plain bearing		if provided for	⊕	⊕			
Cardan shaft intermediate bearing		if provided for			⊕	⊕	
pinion bearing		if grease lubricated	⊕		⊕	⊕	
Brake shaft bearing		Attention ! 2.)	⊕	⊕			
Brake shoe bearing		Attention ! 2.)	Lightly greased at brake shoe new assembly				
Wheel bearing		if grease lubricated	Change grease at wheel hub disassembly				⊕
Wet disk brake	see chapter -7-	external cooled oilchange	dependent on tank volume / cooling system / operation conditions				
		not external cooled oilchange	⊕		⊕	⊕	

(Bh = Hours of operation)

1.) Whichever occurs first .

2.) The bearing point is to be lightly lubricated only , to avoid the penetration of grease in the interior of the brake (use only hand operated grease gun and remove surplus grease !) .

Check regularly the brake shafts and if need correct the lubrication intervals (danger of overheating !) .

Recomendable hypoid gear oils corresp .

MIL - L 2105 B / API GL 5 resp. MIL - L 2105 C / D / API GL 5

ARAL - Gearoil Hyp 90

AVIA - Gearoil Hypoid 90 EP

BP - Multiuse - Gearoil EP SAE 90

ELF - Tranself Typ B 90 / Tranself Typ B 80 W - 90

ESSO - Gearoil GX - D 90

FINA - Pontonic MP SAE 85 W - 90

FUCHS - Renogear Hypoid 90

MOBIL - HD 90 - A

SHELL - Spirax MB 90 / HD 90

TEXACO - Multigear EP SAE 85 W / 90

AGIP - Rotra MP / Rotra MP DB

On no account use „ normal „ gear oils !

General maintenance instructions

Check - and maintenance points	Remarks	Maintenance intervals 1.)				
		after 50Bh 500Km	after 100Bh 1000Km	every 500Bh 5000Km	every 1000Bh 10000Km	min. 1x Year
Wheel bearing	Inspect , if necessary readjust wheel bearing		⊕			⊕
Wheel nuts	Check and tighten with a torque wrench (after tire change after 50km and 200km)	⊕	⊕	⊕		
Castle nuts/track rod Screws/drive flange Nuts/axle mounting bolts	Check and retighten (Verify the adjustment)	⊕	⊕	⊕		⊕
Brakes (see also chapter 7)	Check lining wear , if necessary readjust , control the proper operation of the brake shafts	⊕	monthly			
NLB	Check lining wear					⊕
NLB - spring load design	Check lining wear				⊕	
Steering - and trackrod lever	Check and retighten mounting bolts *)		⊕			⊕
Bolted connections (f. e. drive assembly)	Check from time to time			⊕		
Ring gear support bolt on drive assembly	Readjust (if necessary)					⊕
Seals	Check from time to time	monthly				
Differential lock	Check function and the automatic return in original position	monthly				

(Bh = Hours of operation)

*) If the bolts are moving (Loctite brakes loose) , the lever has to be mounted once more .

1.) Whichever occurs first .

**General instructions for correct
assembly and disassembly
Service tools**

General instructions for correct assembly and disassembly

- The assembly is to be accomplished only by trained personnel .
- The disassembly can be made reverse to the respective assembly instruction .
- Drain oil before removing , check for presence of metal particles .
- Mark the parts to each other before dismantle .
- Never use a hard objekt to separate tightly fitted assemblies . To remove bearings , drive flanges and similair parts , use the proper pullers .
- It is recommended that the special tools according 3.6 used for disassembly .
- Do not place parts on a dirty surface .
- Systematically replace used seals , O - rings and if need bearings on disassembly .
- Clean parts before reassembly .
- Replace or clean corroded parts .
- The cages of bearings rotating in oil are to be coated with oil at reassembly .
- Seal ring treads on flanges , shafts etc. must be preserved with Castrol Rustilo DWX 32 before mounting .
- Oil seal rings and particularly the anti - dust lip seals must be filled with grease .
- The universal joint shafts and the axle shafts must not be force mounted (they must slide) .
- At mounting of radial seal rings pay attention that there is suffice overlap to the housing bores .
Pay attention for a plain alignment of the radial seal ring . The seal lips always must not be contacted with Loctite !
- The bolted or keyed assemblies safeties are to be checked according to instructions ; in case of doubt , consult Kessler & Co .
- Refill the oil after assembly !
- Repair weldment is only allowed after consultation with Kessler & Co !

Using of Loctite and operating supplies

	Type	Colour	Application
1. LOCTITE	243	blue	Lightly locked screws
	262	red	Middle locked screws
	270	green	Highly locked screws
	270	green	Increased coefficient of friction in contact surfaces
	510	orange	Surface gasket
	572	white	Special gasket
	638	light-green	Glueing with big width of slit
2. EPPLE	33	grey	Surface gasket
3. DIRKO		grey	Elastic gasket

Remarks for working up Loctite and operating supplies

- Threads and surfaces have to be cleaned and free from colour , oil and grease before applying Loctite .
- Loctite will harden under following conditions :
 - Exclusion of air
 - Metal contact
 - Increased temperature
- Pre - assembly and control tightening has to be made in a short time (5 to 10 min.) .
- The time between glueing and mounting of the parts should be shorter than 1h .
Exception : parts made from nonferrous metal have to be glued within one minute .
- Assembled parts must remain unloaded for at least 24 hours .
- **Loctite quantity :**
at screws :

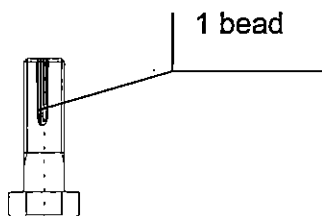

- at contact surfaces :
Pay attention for a sufficient Loctite application !

Utilization of Loctite and operating supplies

Hub assembly			
Safety blocked parts	Joint	Loctite	Operating supplies
Spacer ring	Contact surface	572	-
Axle spindle	Screws	262	-
Axle spindle	Contact surface	270	-
Grommet	in planetary housing	270	-
Disk	in axle spindle	270	-
Adjusting screw with nut	in planetary housing	270	-
Support	Screw	262	-
Ring gear retainer	Screws	270	-
Pol wheel	Contact surface	638	-
Steering lever Track rod lever	Screws	262	-
Steering lever Track rod lever	Contact surface	270	-
Wheel hub cover	Thread	572	-
Radial seal rings Rubber casing	Contact surface	572	-
Radial seal rings Steel casing	Contact surface	270	-
Wheel safety nut → see chapter 5 → Adjustment of wheel bearings			

Utilization of Loctite and operating supplies

Drive assembly			
Safety blocked parts	Joint	Loctite	Operating supplies
Drive flange	Nut surface	-	Epple 33
Diff-housing	Screws	262	-
Shifter cylinder (Diff-lock)	Contact surface	572	-
Diff.carrier (Through drive)	Contact surface	510	-
Drop gear housing	Contact surface	510	-
Diff.carrier	Contact surface	-	Epple 33
Through drive cover	Contact surface	510	-
Differential strap	Screws	262	-
Adjustment nut screw	Screw	270	-
Ring gear	Screws	262	-
Ring gear	Contact surface	270	-
Ring gear support	Cap	270	-
Ring gear support	Thread	-	Epple 33

Tightening torques (Nm)

$$\mu = 0,14$$

Metric standard thread						
Thread	Screw	Nut	Screw	Nut	Screw	Nut
	8.8	8	10.9	10	12.9	12
M 4	3,0		4,4		5,1	
M 5	5,9		8,7		10	
M 6	10		15		18	
M 8	25		36		43	
M 10	49		72		84	
M 12	85		125		145	
M 14	135		200		235	
M 16	210		310		365	
M 18	300		430		500	
M 20	425		610		710	
M 22	580		830		970	
M 24	730		1050		1220	
M 27	1100		1550		1800	
M 30	1450		2100		2450	
Metric fine pitch thread						
Thread	Screw	Nut	Screw	Nut	Screw	Nut
	8.8	8	10.9	10	12.9	12
M 8 x 1	27		39		46	
M 10 x 1	55		81		95	
M 10 x 1,25	52		76		90	
M 12 x 1,25	93		135		160	
M 12 x 1,5	89		130		155	
M 14 x 1,5	145		215		255	
M 16 x 1,5	225		330		390	
M 18 x 1,5	340		485		570	
M 20 x 1,5	475		680		790	
M 22 x 1,5	650		920		1050	
Brake caliper dowel screws (greased !)						
M 20 x 1,5	400 + 100					
M 27 x 2	900 + 100					
Nut for steering stop = 300 Nm						

Regard reduced tightening torque for galvanized bolts and nuts !

Tightening torques of wheel nuts

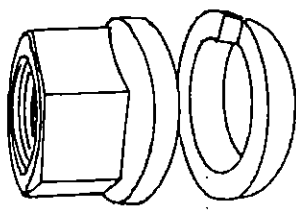
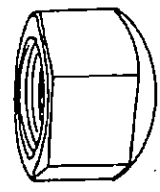
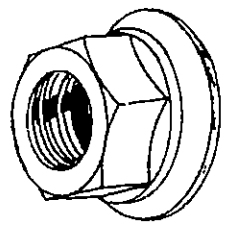
		
<p>Wheel nut with spring lock washer</p>	<p>Wheel nut with clamp (for clamp fixation)</p>	<p>Wheel nut with thrust collar (for rims with centerring)</p>

Wheel nut with spring lock washer		
Dimensions	Phosphorous darkened	Galvanized
M 18 x 1,5	270 Nm	250 Nm
M 22 x 1,5	450 Nm	350 Nm

Wheel nut with thrust collar		
Dimensions	Phosphorous darkened	
M 22 x 1,5	650 Nm	

Wheel nut with clamp		
Dimensions	Galvanized	
M 18 x 2	350 Nm	

Tightening torques for castle nuts on ball joints for track rods and ram cylinders

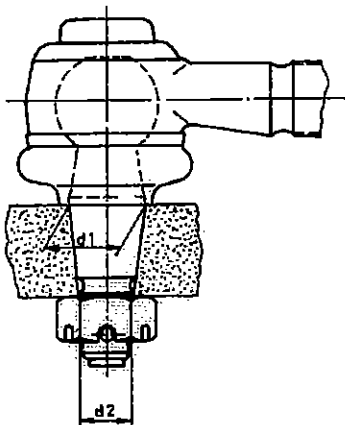

Cone size d1 (mm)	Thread d2 (mm)	Torque (Nm)
26	M 20 x 1,5	200 - 220
30	M 24 x 1,5	280 - 300
32	M 27 x 1,5	290 - 320
38	M 30 x 1,5	340 - 360
45	M 39 x 1,5	410 - 430

The tightening torques of the different thread dimensions of the joints are applicable for nuts of quality S6 .

Tightening torque of the adjusting nut resp. slotted nut at flanges resp. gearwheels ect.

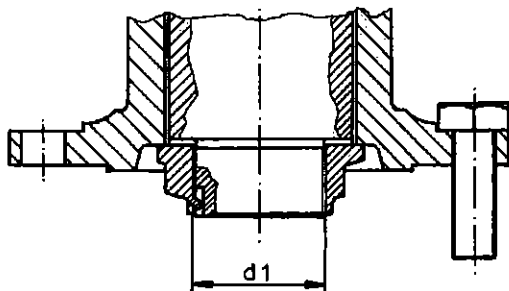

Thread d1 (mm)	Torque (Nm)
M 24 x 1,5	360
M 30 x 1,5	450
M 36 x 1,5	540
M 42 x 1,5	850
M 45 x 1,5	850
M 48 x 1,5	850
M 52 x 1,5	950
M 64 x 1,5	1050 - 1100

Service tools

When ordering service tools please provide order number (installation drawing no.) , resp. fabrication number → see identification plate . (The illustrations are not binding for the design) .

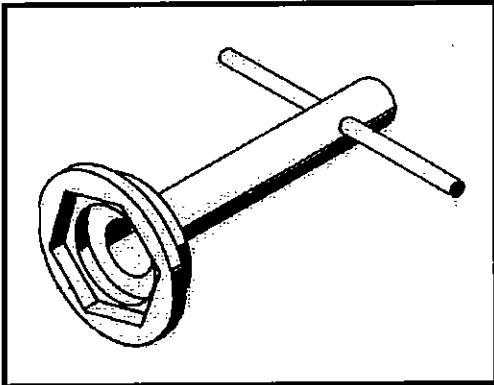

Spanner for wheel safety nut

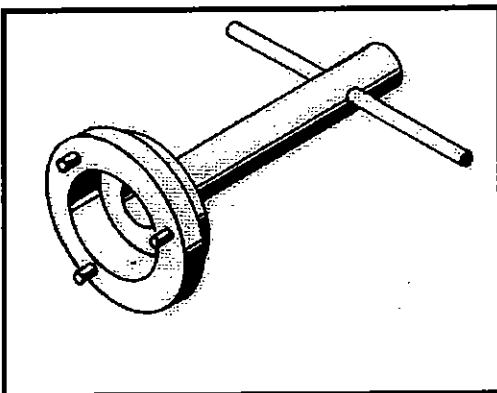

Spanner for splined nut (hub assembly)

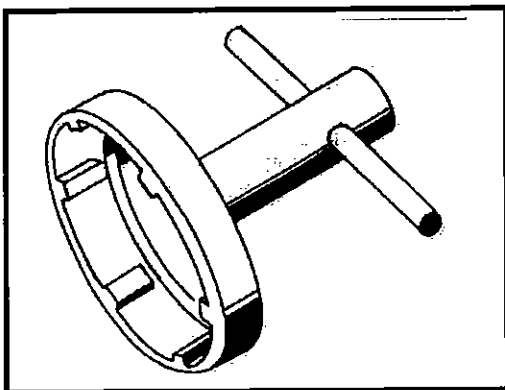

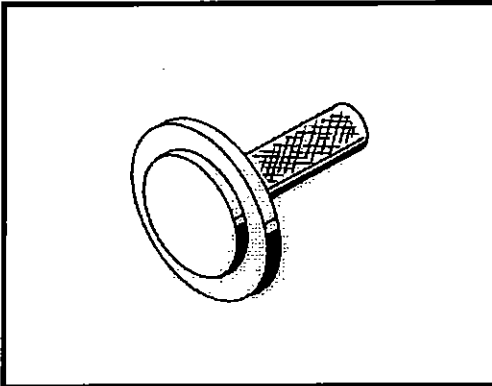
Service tools

Seal ring sleeve driver

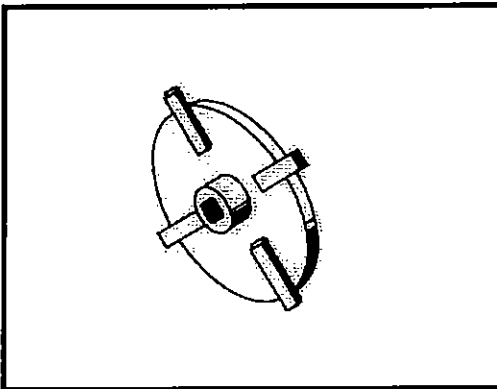
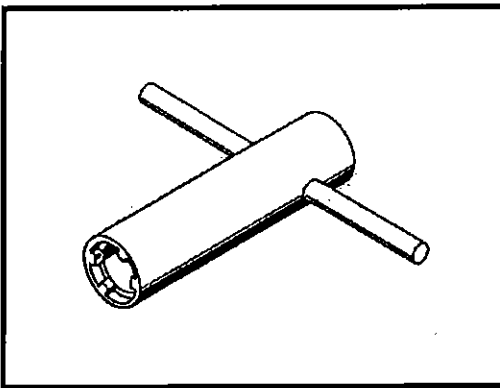
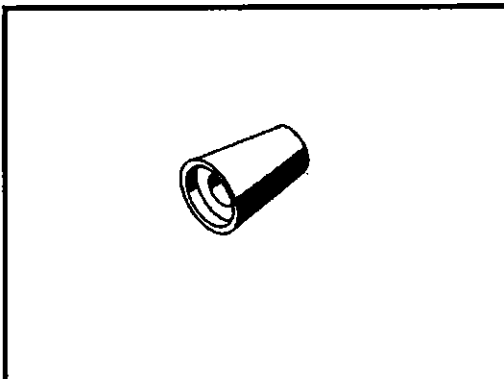
Spanner for thread rings
(differential bearing)Spanner for counter nut
(planetary gear drive)Assembly cone for o - ring
(differential lock)

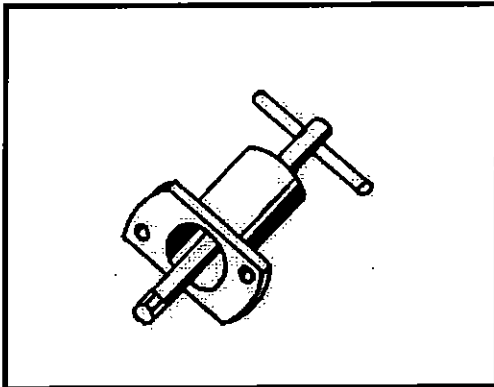
Service tools

Assembly sleeve for piston
(differential lock)

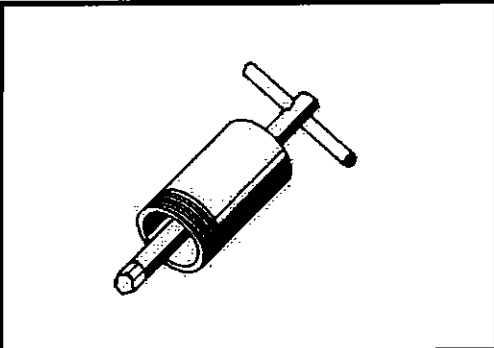

Assembly sleeve for piston
(differential lock)

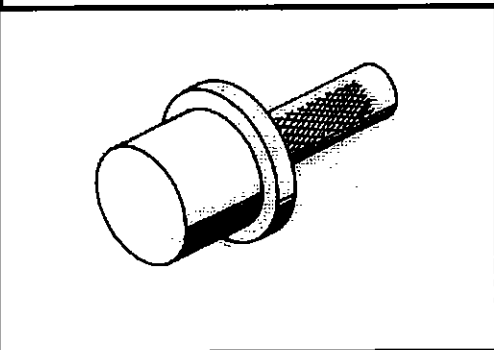

Sleeve driver for universal joint bearing
(needle bearing / bearing bushing)

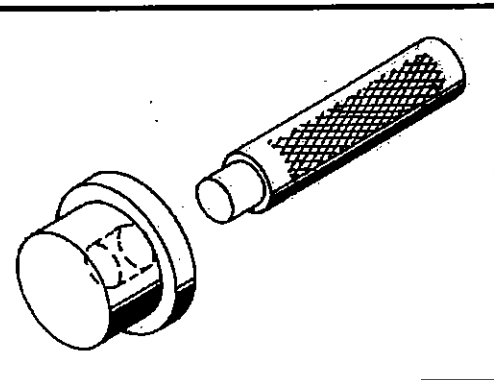

Sleeve driver for bearing bushings
(steering knuckle bearing)

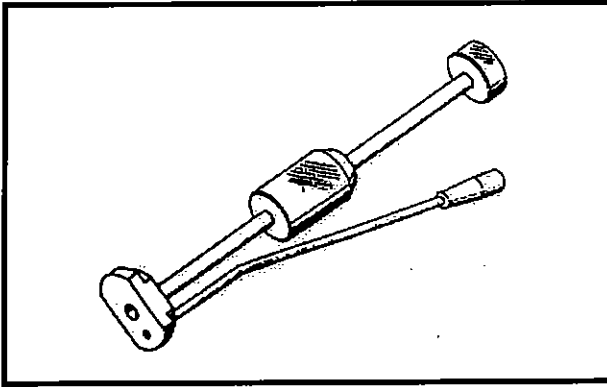
Service tools

Puller for universal joint bearing
(needle bearing / bearing bushing)

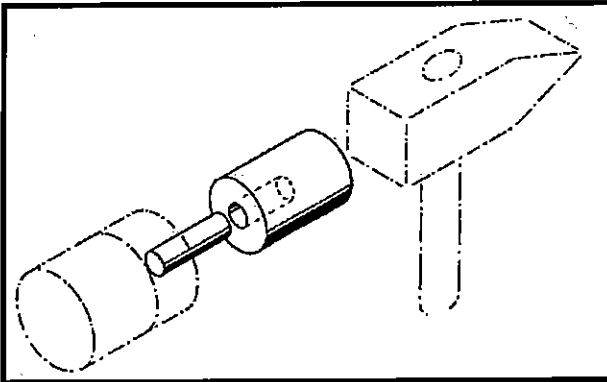

Device to press in king pins

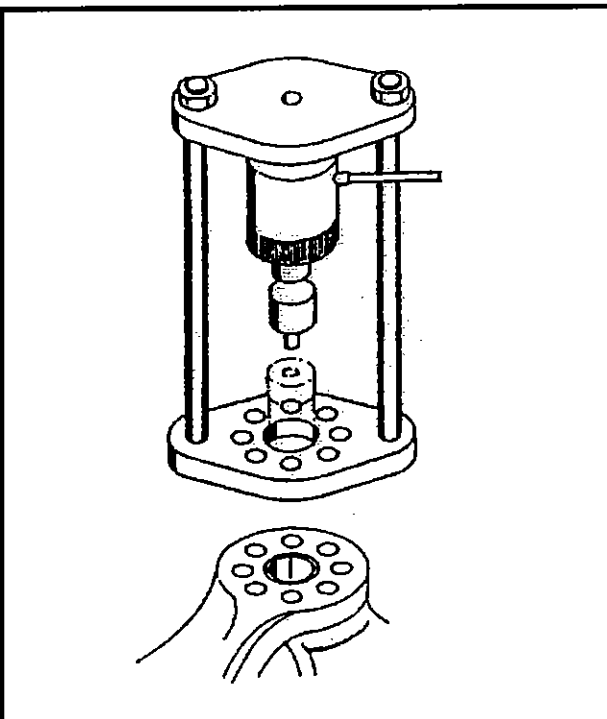

Hydraulic device to press in king pins

Service tools

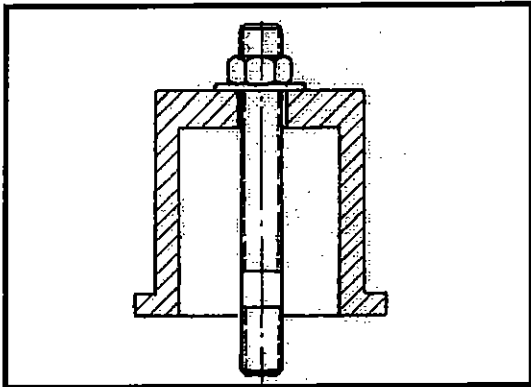

Mechanical puller for king pins

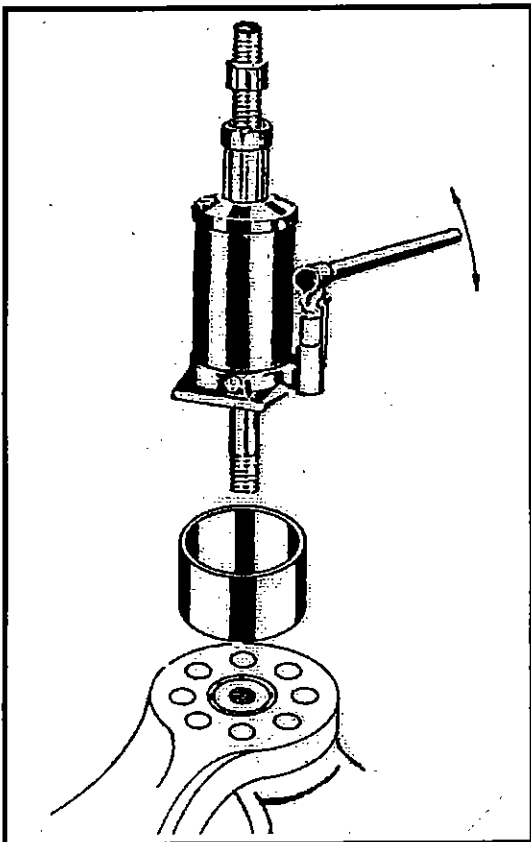

Hydraulic puller for king pins

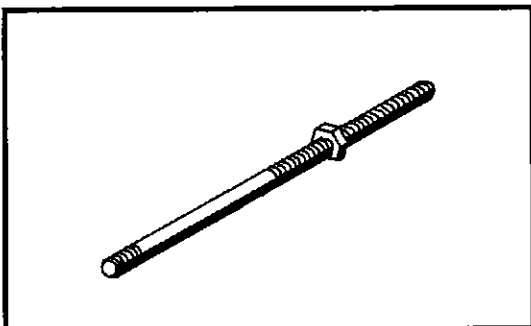

Screw spindle for king pin pullers

Assembly drive assembly

Adjustment of gear meshing of Gleason gears

To become a perfect gear meshing is only possible , if the fabrication number of the drive pinion (marked on the end face) and the ring gear (marked on the circumference) are corresponding .

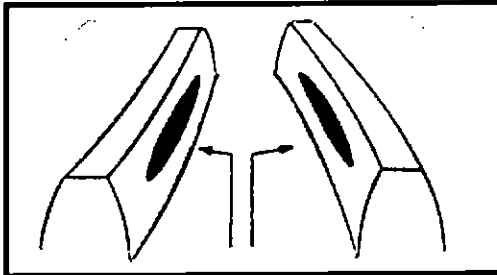

Perfect marking .

The following figures are showing improper gear meshing marks of the ring gear . The text alongside gives the corrections to obtain correct gear meshing . The dark colored arrows in the sketch of the drive pinion and ring gear are indicating the direction towards which the drive pinion has to be moved . The clear arrows are indicating the direction towards which the ring gear has to be moved , to get further more a correct backlash .

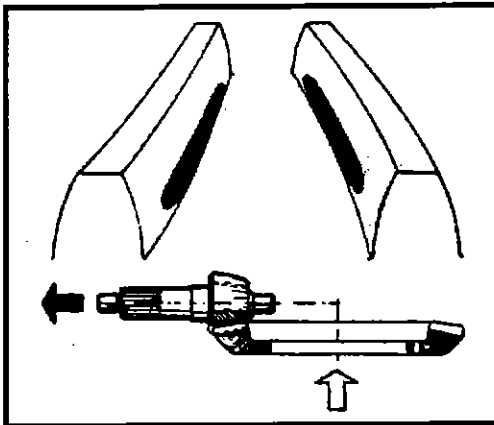

Gear meshing too deep .

Increase the drive pinion distance by correction of the adjustment disk thickness .

Regulate the backlash by inwards moving of the ring gear .

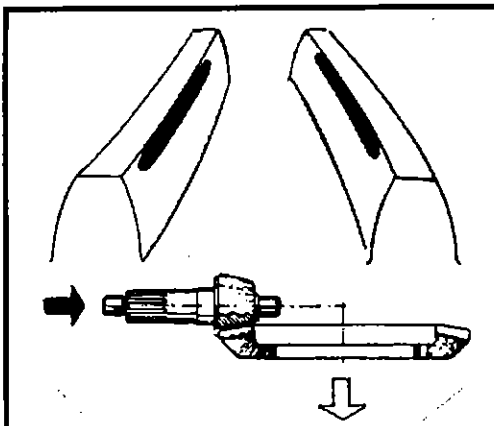

Gear meshing too high .

Decrease the drive pinion distance by correction of the adjustment disk thickness .

Regulate the backlash by outwards moving of the ring gear .

Securing of the striking nut

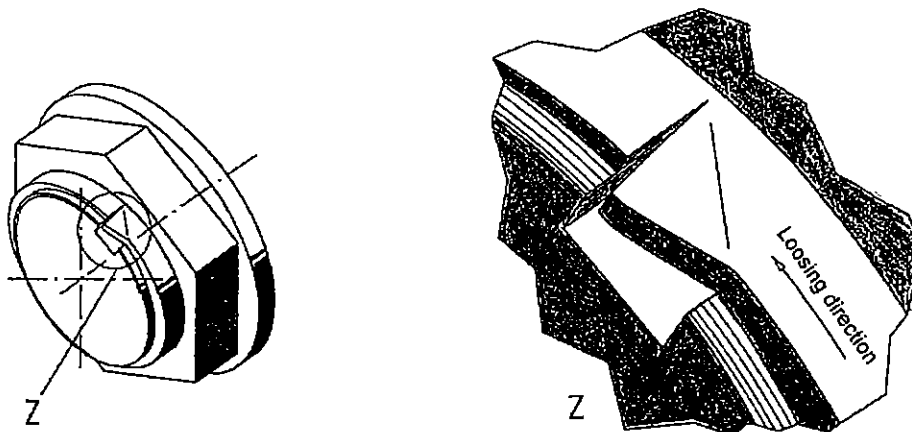

The brim of the striking nut has to be sheared only along the slot flank and the corner has to be bended on the slot ground .

Using of Loctite and other operating supplies

1.) Striking nut at drive flange

- In thread : assembly paste with MoS₂ (exception through drive pinion see point 2) .
- Front side contact surface : sealing compound (Epple 33 or equivalent) .

2.) Striking nut at through drive pinion

- In thread : Loctite 262 .

3.) Striking nut at gear wheels , bearings etc.

- In thread : assembly paste with MoS₂ .

Removing of the striking nut

Bend away the nose and screw off the nut .

Achsantrieb D 41

Drive assembly D 41

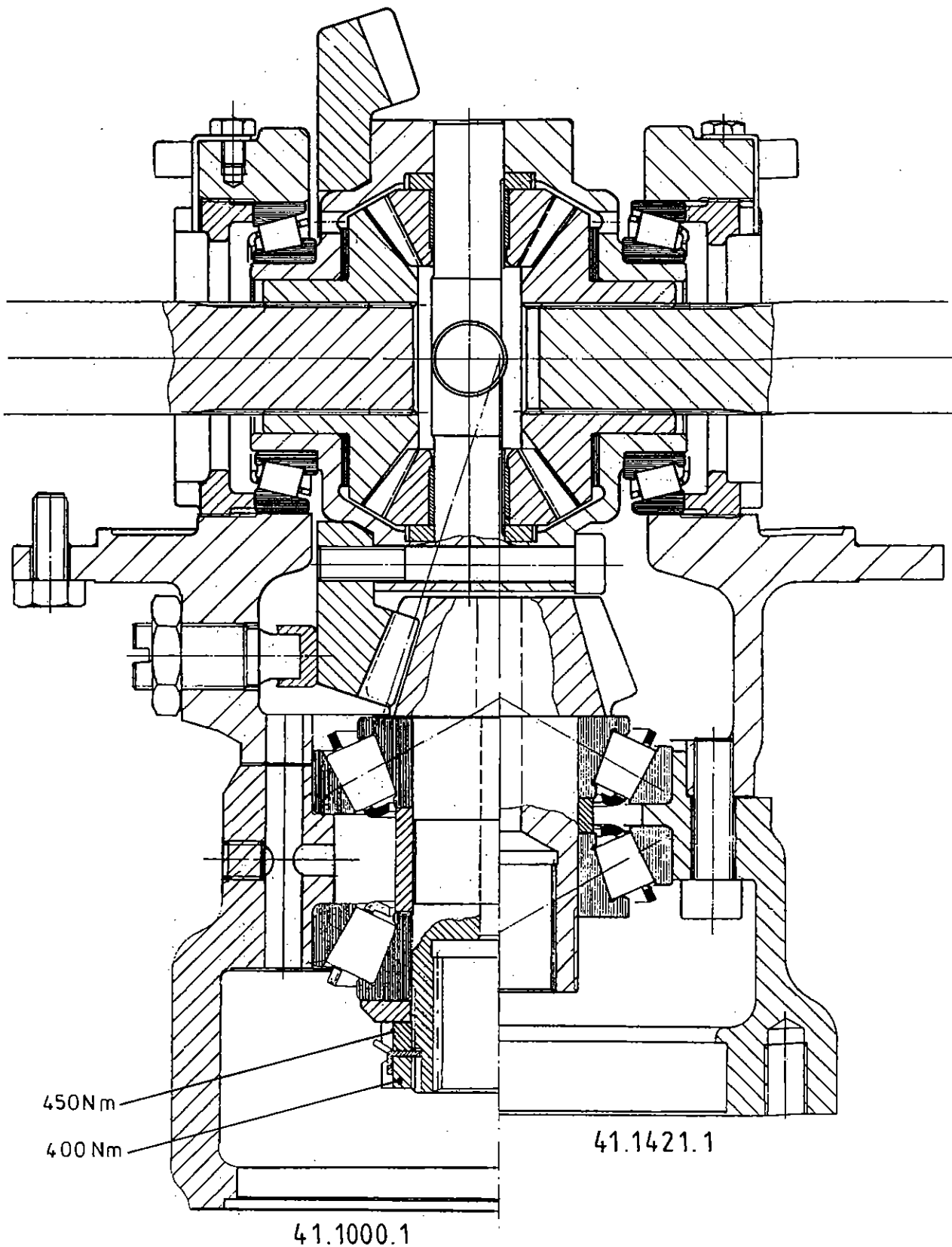

Assembly of the drive pinion bearing

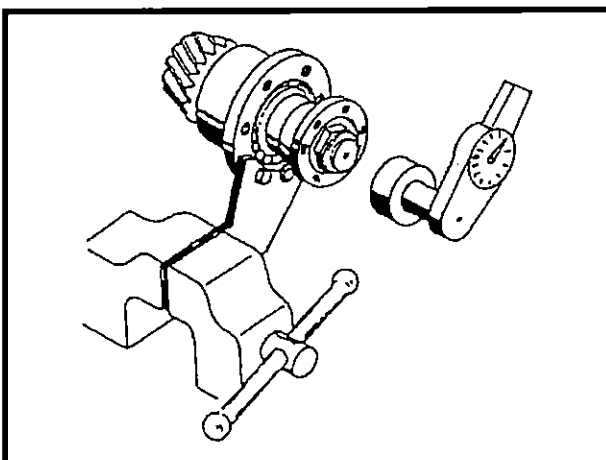
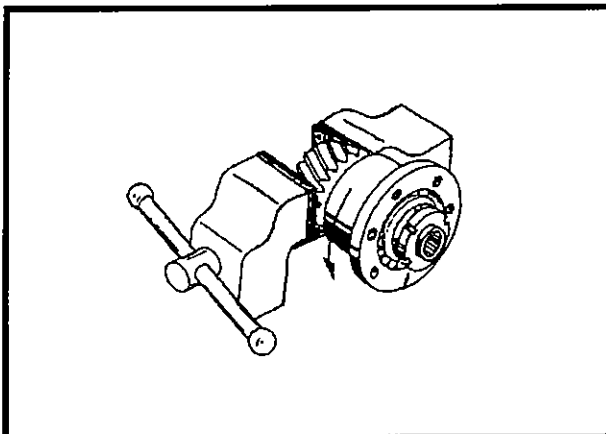
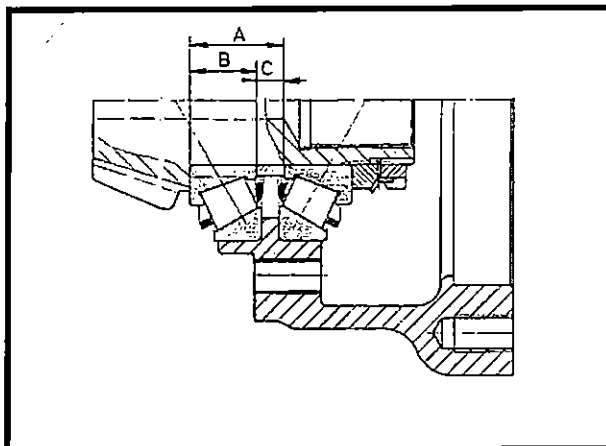

1. Insert the two outer rings of the taper roller bearings into the pinion housing .
2. Calculate the thickness C of the spacer bushing.
 - a) Place the two inner rings of the taper roller bearings in their outer rings . Measure A or C .
 - b) Measure the dimension B of the taper roller bearing .
 - c) Thickness of the spacer bushing $C = A - B$
3. Heat the drive pinion side taper roller bearing to about $100^{\circ}C$ and install it on the drive pinion shaft. (Drive on completely after it cools) .
4. Install the spacer bushing on the pinion shaft .
5. Install the pinion housing onto the drive pinion . Heat the taper roller bearing inner ring at undersize to about $100^{\circ}C$ and install it with a tube onto the drive pinion shaft .
6. Tighten the safety nuts by turning the pinion housing (tightening torque : inner nut = 450 Nm , outer nut = 400 Nm) . For tightening , place the drive pinion in a vice using soft jaws .
7. Measure the roll resistance of the bearings by using a torque wrench . If the measured value is not prescribed (see table) , adjust the resistance by modification of the thickness of the spacer bushing . After arriving at the adjustment of the bearing secure the nuts with the lock plate .

drive assembly	roll resistance
41.1000.1	0,8 - 1,5 Nm
41.1421.1	0,5 - 0,8 Nm

Adjustment of gear meshing

Set the complete mounted drive pinion into the differential carrier and bolt it .

Ascertaining of the thickness S of the adjustment disks :

To obtain the proper tooth flank contact according sheet „ adjustment of gear meshing of Gleason gears „ , adjust the axial position of the drive pinion with the thickness of the adjustment disks . The necessary thickness of the adjustment disks can be obtained by successive trials .

(For this operation the differential have to be mounted onto the differential carrier → see sheet „ assembly of drive assembly „) .

After the adjustment of gear meshing bolt the pinion housing onto the differential carrier , seal the pinion housing with Loctite 572 .

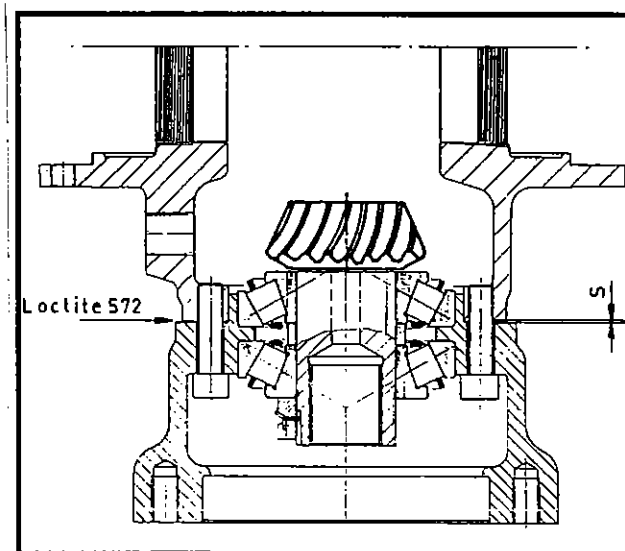

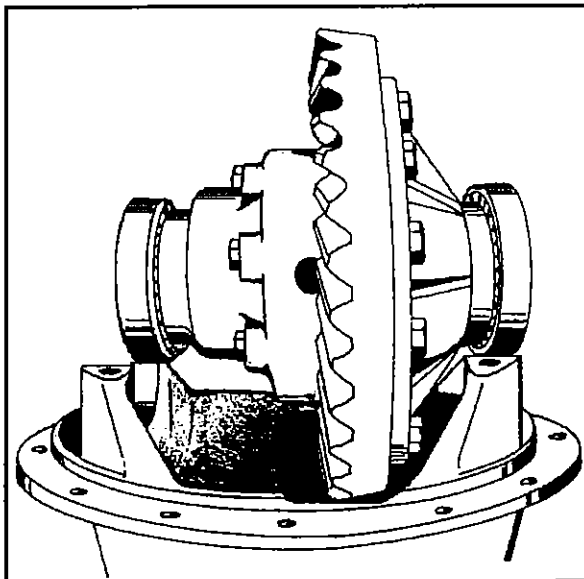

Assembly of drive assembly

Place the differential with the outer rings of the taper roller bearings on the differential carrier which is in a vertical position, with mounted drive pinion.

Mount the differential straps and align them with the thread rings.

During this operation be careful of the alignment marks on the differential straps with respect to the differential carrier. (Do not interchange the differential straps.)

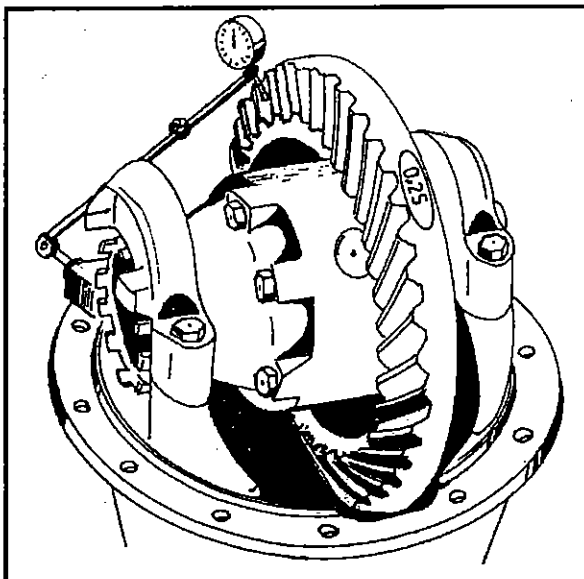

Hand tighten the differential strap bolts. By a counter rotation of the two thread rings, move the differential until the backlash is correct. (The smallest admissible value at the closest place is marked on the ring gear).

Therefore hold the drive pinion at the drive flange. Check the backlash by careful forwards and rearwards rotating the ring gear. Use a dial indicator.

Measure the backlash during a few times turns of the ring gear and if need correct the backlash, because of the smallest admissible value at the closest place must not be fall short of.

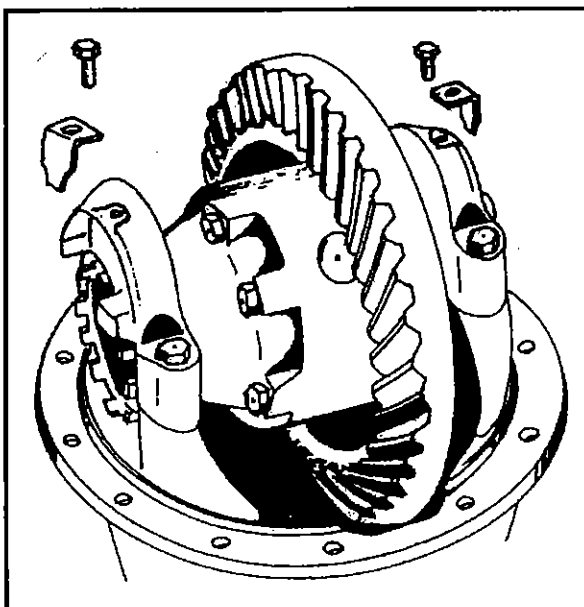

Adjust gear meshing according to sheet „Adjustment of gear meshing of Gleason gears“.

Tighten screws of the differential straps and lock them with Loctite 262.

Adjust the bearing roll resistance trough tightening of the thread rings. Set value : 2,0 to 3,0 Nm. Check the value with a torque wrench. If measuring at the drive pinion / drive flange, take the ratio of the bevel wheel set into account.

Screw the lock plates for the thread rings and secure with Loctite 270, if need bend the lock plates.

Assembly of the Differential

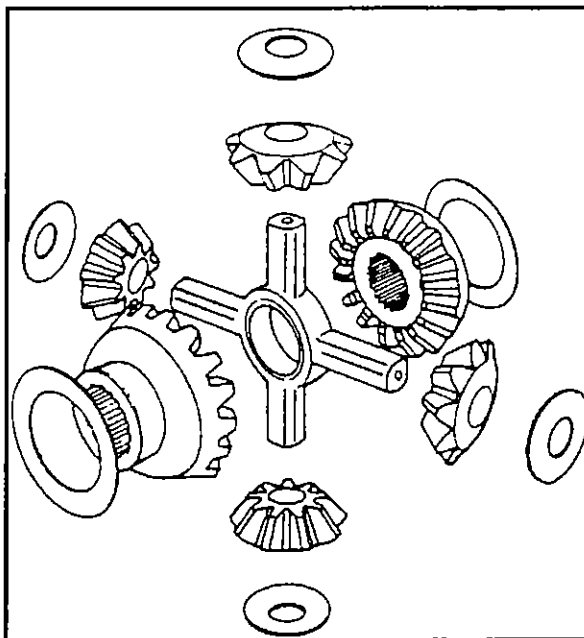

Before assembly all of the bevel gears and the thrust rings should be well oiled.

1. Place one differential side gear with the side gear thrust washer in the differential case.
2. Install the spider with differential gears and differential pinion thrust washers in the differential case.
3. Install the other differential side gear and side gear thrust washer. (At variants with Nospin differential install the Nospin diff. instead of the differential gears)
4. Install the other half of the differential case over the assembly and observe the alignment marks, tighten the differential case bolts. Secure with Loctite 262.
5. Check that all differential pinions can rotate easily.
6. Coat the contact surface of the ring gear with Loctite 270 and install the ring gear on the differential case by tapping lightly on the circumference. Tighten the ring gear bolts. Secure with Loctite 262.
7. Heat the two taper roller bearings to about 100°C and install them by using a sleeve.

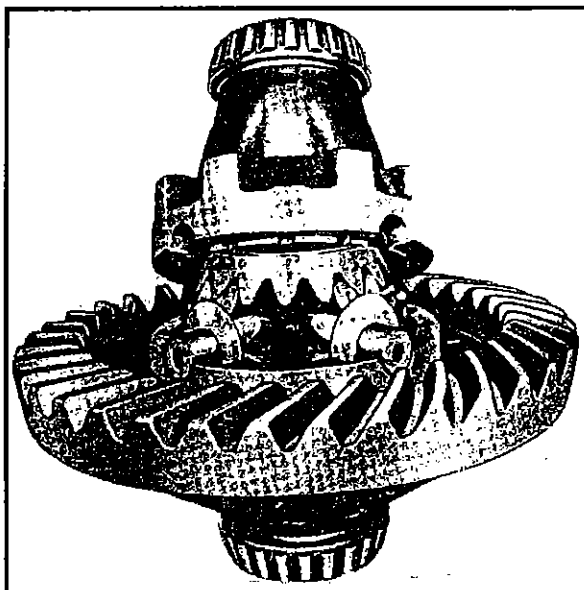
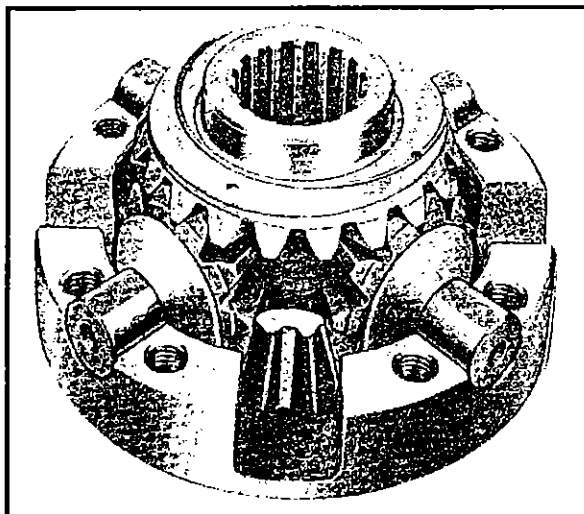

Assembly of the ring gear support bolt

1. Glue the cap with Loctite 270 onto the support bolt .
2. Coat the support bolt with Epple 33 .
3. Screw the support bolt with cap by hand to contact to the ring gear , without exert pressure .
4. Screw the counter nut onto the support bolt .
5. Turn back the support bolt max. 15 ° .
6. Tighten the counter nut , during this operation the support bolt must not move .

In tightened condition the clearance between the ring gear surface and the contact surface of the support bolt amount about 0,1 mm .

Attention :

The support bolt has to be sealed again when adjusting timely .

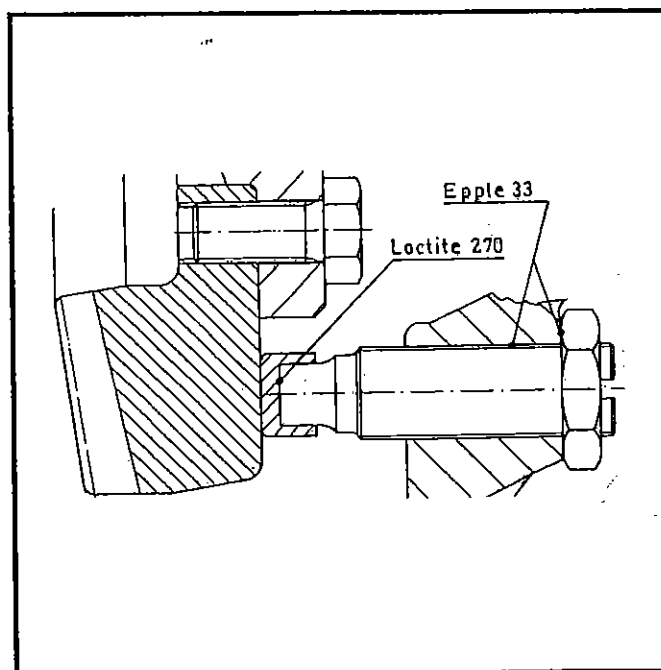

Assembly hub assembly

Radseite Lenktriebachse
Hub assembly steer drive axle

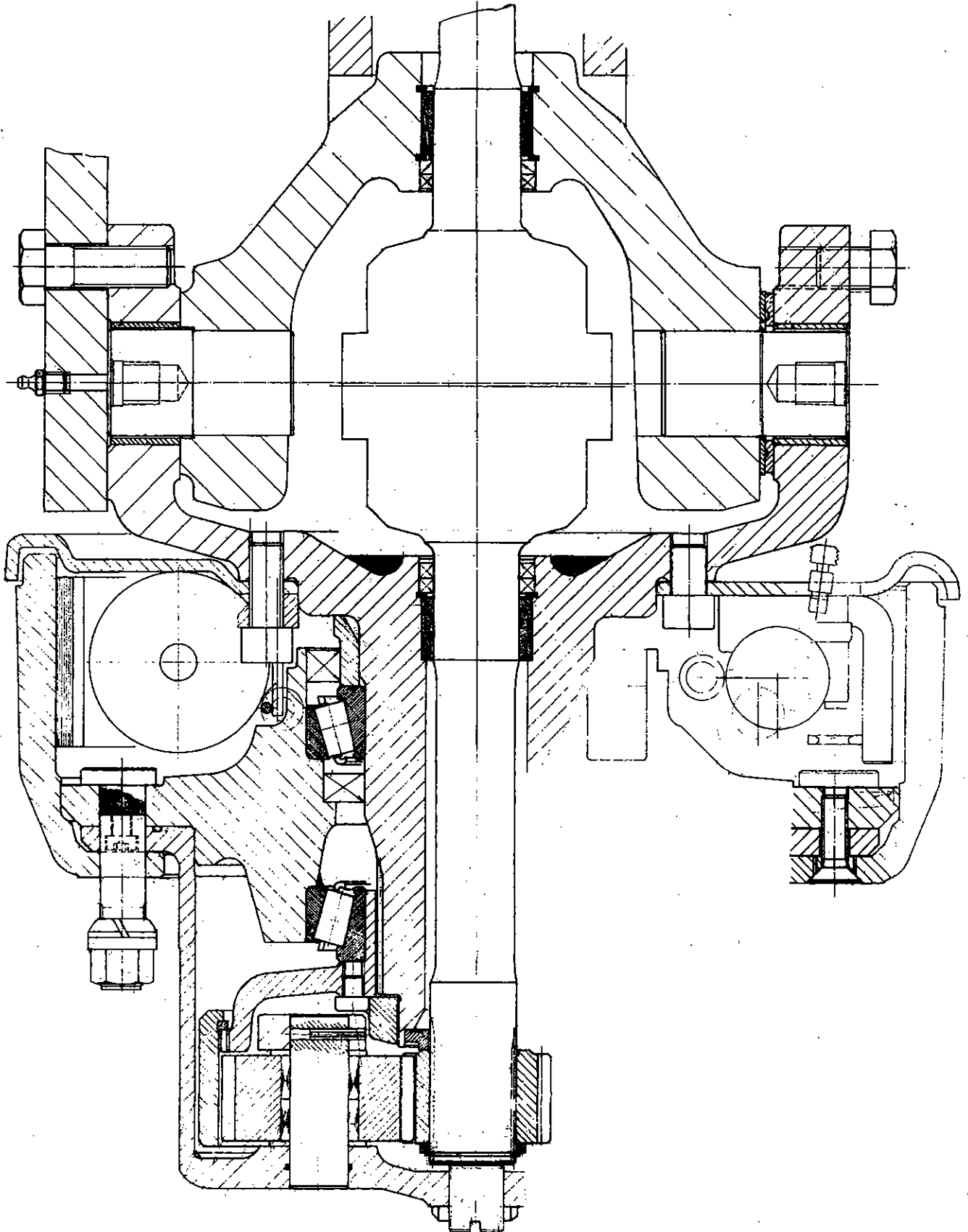

Assembly bearing of steering knuckle and bearing of universal joint

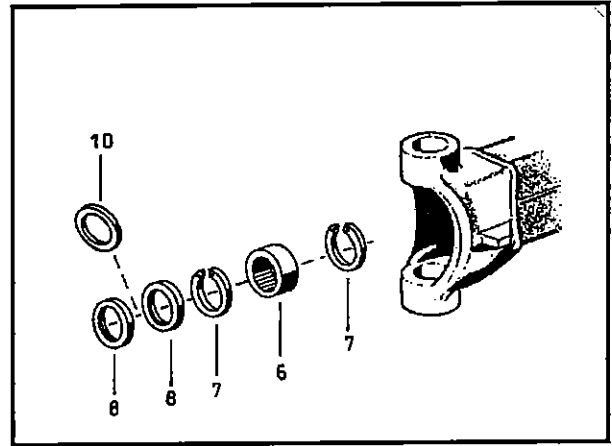
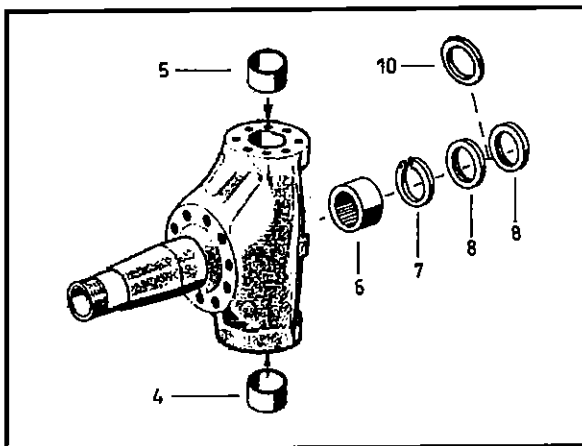
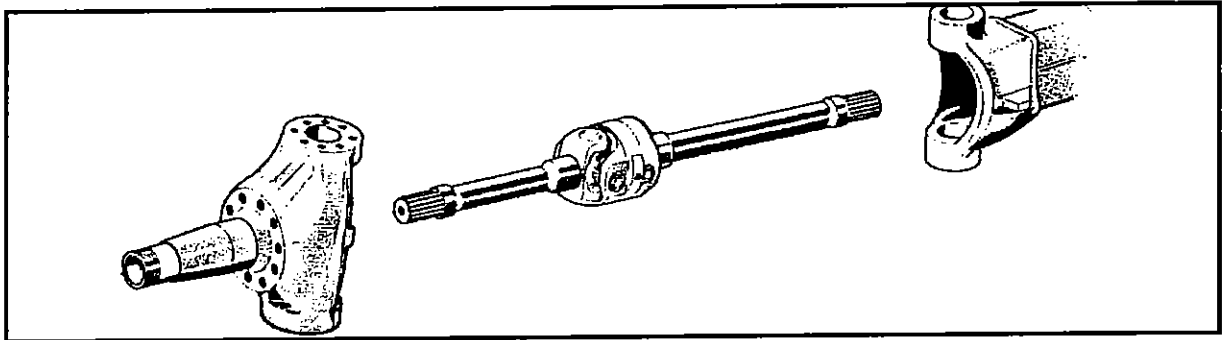

Prepare the steering knuckle:

- Assembly of the spacer ring (if present) see sheet 5.1.6.
- Introduce the bearing bushing (4) into the lower bore of the steering knuckle and press in, by using a sleeve. Press in the upper bearing bushing (5), by using a sleeve, into the upper bore of the steering knuckle. (At version with spring support the upper bearing bushing (5) has to be mounted after installation of the king pin).
- Press the bearing (6) into the steering knuckle and secure it with the circlip (7). Install the seal rings (8) with Loctite 572 resp. 270, place the support disk (10) (if present) between the seal rings. Fill the seal rings with bearing grease.

Prepare the axle housing:

- Insert the inner cliclip (7) into the axle housing. Press the bearing (6) into the axle housing and secure it with the second circlip (7). Install the seal rings (8) with Loctite 572 resp. 270, place the support disk (10) (if present) between the seal rings. Fill the seal rings with bearing grease.

Assembly of the drive assembly onto the axle housing

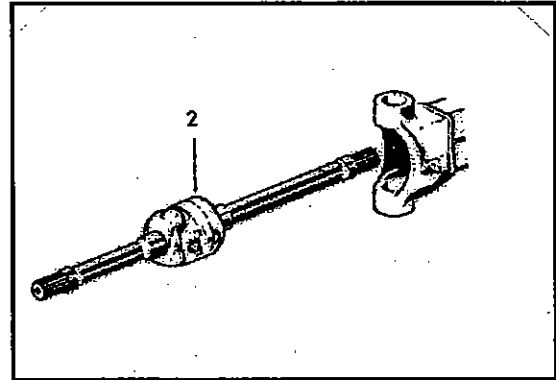
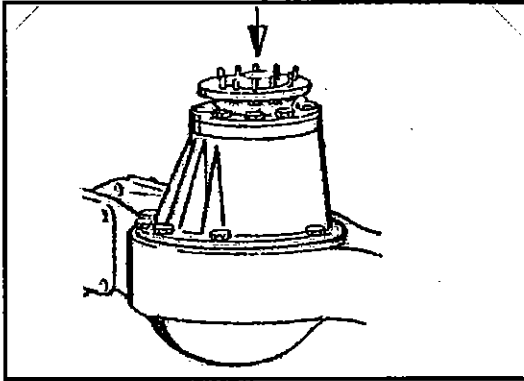

Coat the contact surface of the axle housing with Epple 33 (at version through drive with Loctite 510), and mount the complete drive assembly. The axle housing being placed in a horizontal position, secure the screws with Loctite 262. Mount the pol wheel (if present) onto the universal joint (see 5.1.7).

Very carefully engage the long shaft of the universal joint into the axle housing.

The universal joint shaft should be able to be moved easily (by hand) in the tothing of the differential side gear.

At version with differential lock on the outside (D 71 / D 109) the differential lock must always be actuated when assemble or disassemble the universal joint.

Direction:

Actuating of the differential lock is necessary to prevent the sliding sleeve to drop out of the shifter fork into the axle housing when pulling out or sliding in the universal joint. This would entail disassembly of the axle.

Assembly of the steering knuckle onto the axle housing

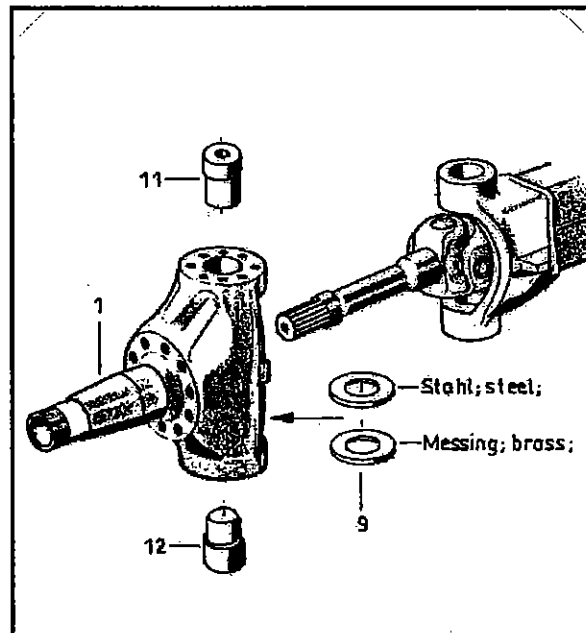

At version with maintenance reduced steering knuckle bearing install the o-rings according the respective version.

Fit the steering knuckle (1) onto the axle fork. **Caution:** Be very carefully and do not damage the seal rings in the steering knuckle with the universal joint shaft!

Introduce the thrust disks (9) according the respective version.

Before mounting the king pins apply Molykote – powder or – paste on the pins and in the bores (danger of gripping).

Press in the king pins (11 + 12).

Disassembly king pin:

Draw off the lower king pin to the bottom, and the upper king pin to the top.

Assembly of steering- resp. track rod lever

Important : threads and surfaces have to be cleaned and free from colour , oil and grease before applying Loctite .

Note further remarks for working up Loctite (see sheet 3.2) .

Coat the contact surface between lever (6 resp. 13) and steering knuckle at the contact area with Loctite 270 and install the lever by screws onto the steering knuckle , secure the screws with Loctite 262 . Hardening time of Loctite 270 = 24 hours .

Coat the contact surface between cover (7 resp. 14) and steering knuckle with Loctite 510 and install the cover by screws onto the steering knuckle .

Screw the grease nipples into the lever resp. cover and grease the steering knuckle bearing with bearing grease according the lubrication plan 2.3 .

At version with dowel pins for increased torque , the dowel pins have knocked in before tightening the screws , note the position of the slits in the dowel pins (180° turned to one another) .

Steer drive axle

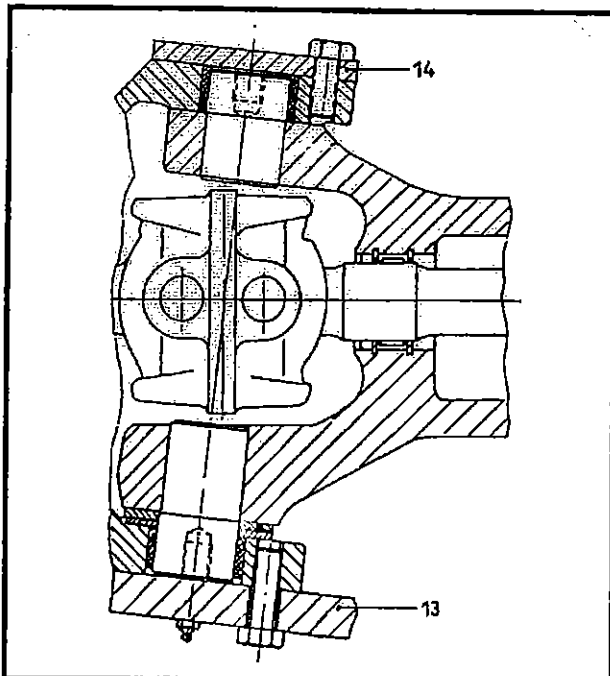

Steer axle

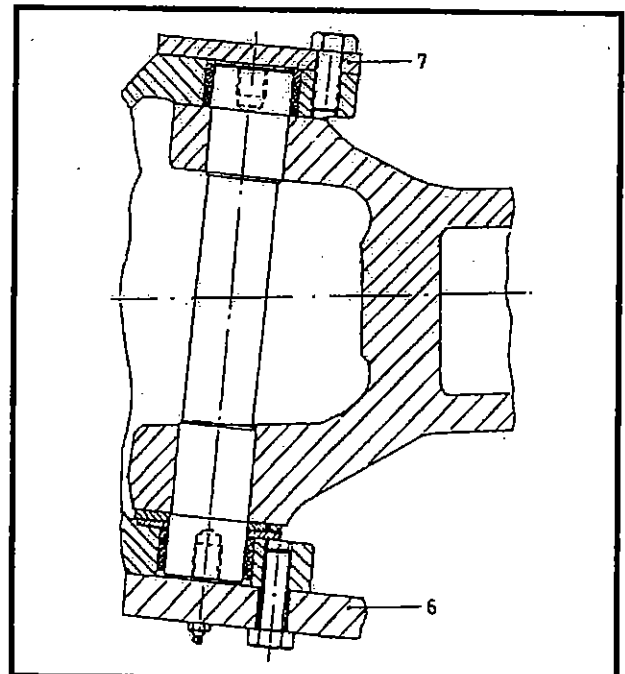

Assembly hub assembly

- Assembly of the spacer ring (if present) see sheet 5.1.6 .
- Install the brake onto the steering knuckle , be careful of the brake control position and bolt it . At version with disk brake install the brake carrier (if present) , then mount the wheel hub with the brake disk , and after this operation install the brake .
- Prepare and mount the wheel hub see chapter 5.5 .
Attention : Hold the wheel hub with a hoist till the outer bearing with ring gear carrier is mounted .
- Assembly of the planetary gear drive see chapter 6 .
- At version with drum brake mount the brake drum .
- Assembly of the ABS - sensor installation (if present) see 5.1.7 .

Assembly of the spacer ring

Coat the seat of the spacer ring on the steering knuckle resp. axle spindle with Loctite 572 . Heat the spacer ring to about 100 ° C and push him by gently striking onto the steering knuckle resp. axle spindle . (The steering knuckle resp. axle spindle must be free of corrosion) . Oil the seal ring tread onto the spacer ring .

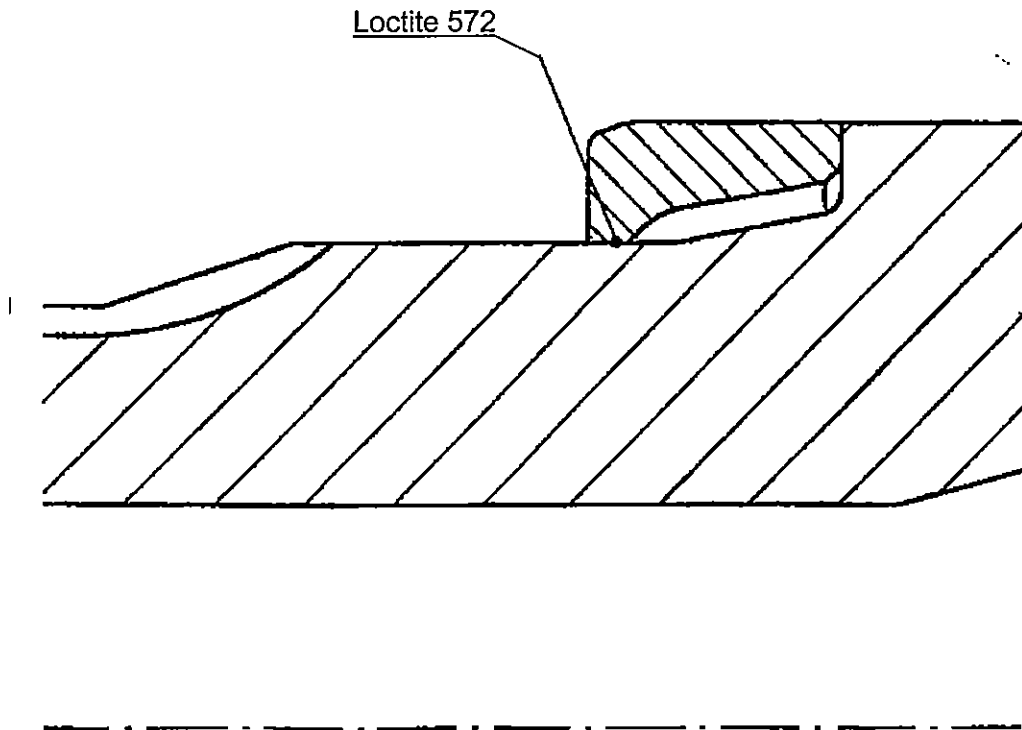

Radseite Antriebsachse
Hub assembly drive axle

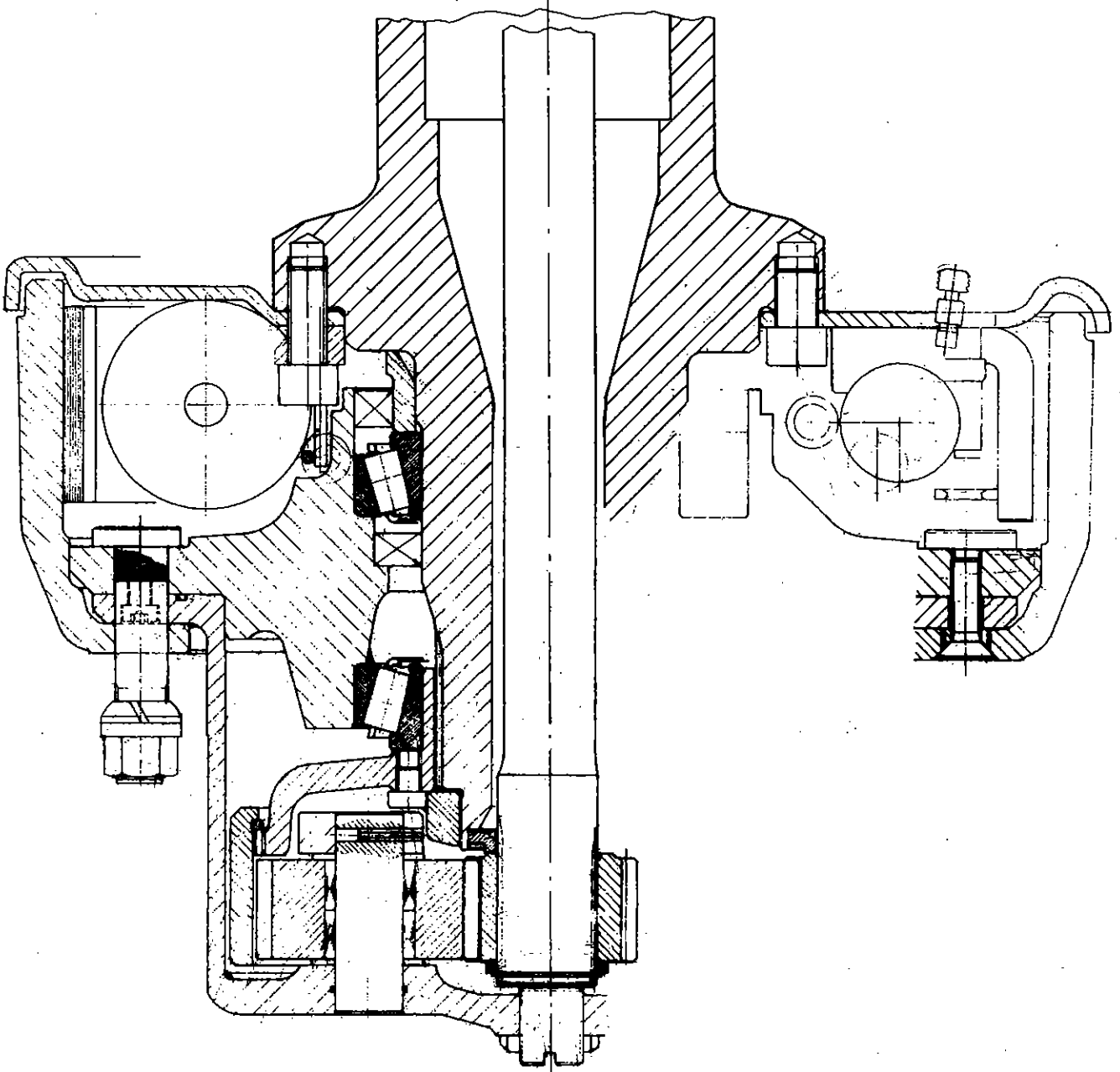

Assembly of the drive assembly onto the axle housing

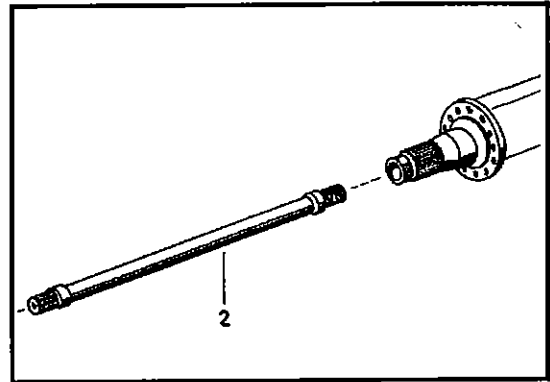
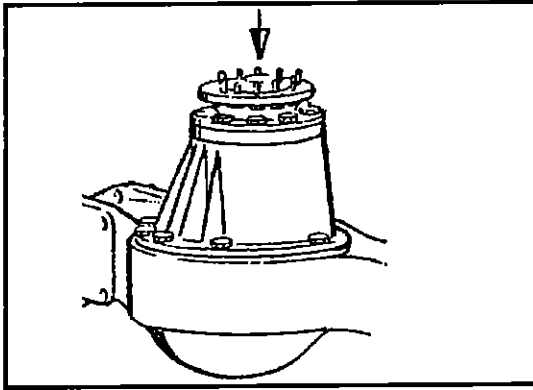

Coat the contact surface of the axle housing with Epple 33 (at version through drive with Loctite 510), and mount the complete drive assembly. The axle housing being placed in a horizontal position, secure the screws with Loctite 262. Mount the pol wheel (if present) onto the axle shaft (see 5.1.7).

Engage the axle shaft into the axle housing.

The axle shaft should be able to be moved easily (by hand) in the tothing of the differential side gear.

At version with differential lock on the outside (D 71 / D 109) the differential lock must always be actuated when assemble or disassemble the axle shaft.

Direction:

Actuating of the differential lock is necessary to prevent the sliding sleeve to drop out of the shifter fork into the axle housing when pulling out or sliding in the axle shaft. This would entail disassembly of the axle.

Assembly hub assembly

- Assembly of the spacer ring (if present) see sheet 5.1.6 .
- Install the brake onto the axle spindle , be careful of the brake control position and bolt it .
At version with disk brake install the brake carrier (if present) , then mount the wheel hub with the brake disk , and after this operation install the brake .
- Prepare and mount the wheel hub see chapter 5.5 .

Attention : Hold the wheel hub with a hoist till the outer bearing with ring gear carrier is mounted .

- Assembly of the planetary gear drive see chapter 6 .
- At version with drum brake mount the brake drum .
- Assembly of the ABS - sensor installation (if present) see 5.1.7 .

Attention :

At version with ABS resp. ABS - preparation (the pol wheel is mounted onto the axle shaft) the thrust ring of the sun gear in the axle spindle must be dismounted for disassembly the axle shaft .

Prepare wheel hub

Install the wheel studs (1) .

Press the radial seal ring (2) with Loctite 572 (rubber cage) resp. Loctite 270 (steel cage) applied into the wheel hub (5) . Fill the radial seal ring with bearing grease .

Press in outer rings of taper roller bearings (3 + 4) , do not hammer them .
Install inner ring of taper roller bearing (3) . Fill the taper roller bearing with bearing grease .

Press the radial seal ring (6) with Loctite 572 (rubber cage) resp. Loctite 270 (steel cage) applied into the wheel hub . Fill the radial seal ring with bearing grease .

At version with cassette seal ring observe the mounting instruction 5.6 .

Mount wheel hub

Push the pre - assembled wheel hub (5) parallel onto the axle spindle resp. steering knuckle .

Attention : Be carefully do not damage the seal rings (2 + 6) .

At version with cassette seal ring observe the mounting instruction 5.6 .

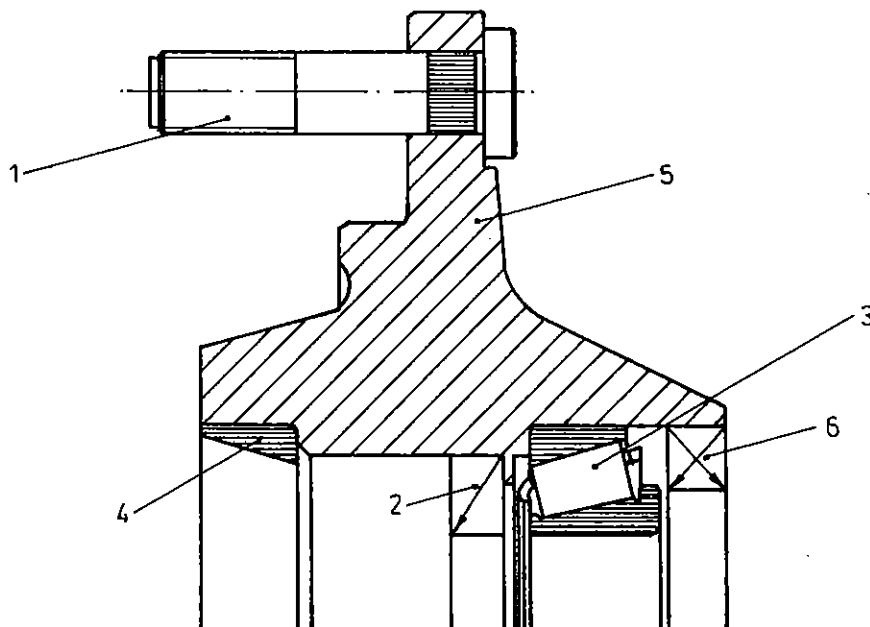

Adjustment of wheel bearings

Tightening torque of the wheel safety nut

Series	Nm
41 51	300 350
61, 71 81	400 450
91 109 116	500
106 L101 L102 D / LT 101 / 102	500 550 650
111 112	750 1000

Adjusting of wheel bearings

The temperature of the axle parts should be between 0 and + 20° C at the bearing adjustment .

Screw on the wheel safety nut (Loctite- resp. Molykote- using see page 5.7.2) and adjust and secure as following described :

Screw on the wheel safety nut and tighten it with a 1,5 to 2 times higher tightening torque than the finish tightening torque . During the tightening , turn the wheel hub a few times and knock it with a plastic hammer . Untighten the wheel safety nut (about 180° back rotation) , then tighten the wheel safety nut to the tightening torque according to the table . At this tightening turn the wheel hub also a few times , if there is no possibility for securing , the wheel safety nut has to be turned back to next securing possibility .

Radsicherungsmutter

Wheel safety nut

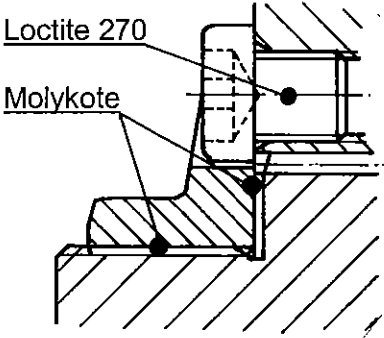
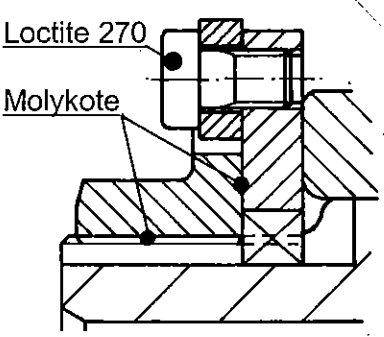
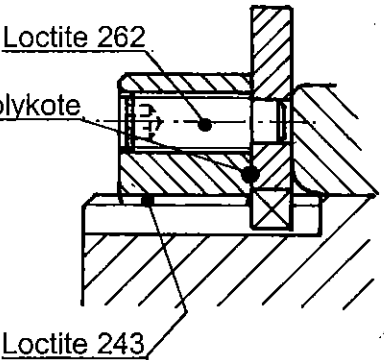
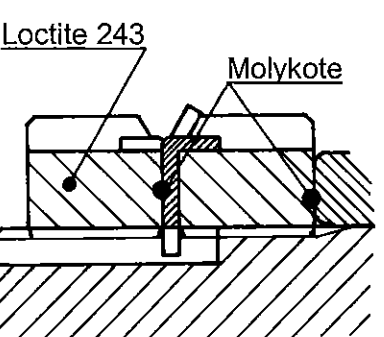
Bezeichnung Designation	Ausführung Version	Sicherung / Bemerkungen Security / Remarks
<p>Wellenmutter mit Zylinderschraube</p> <p>Shaft nut with cheese head screw</p>		<p>Zylinderschraube</p> <p>Cheese head screw</p> <p>& Loctite 270</p>
<p>Wellenmutter mit Zylinderschraube und Buchse</p> <p>Shaft nut with cheese head screw and bushing</p>		<p>Zylinderschraube</p> <p>Cheese head screw</p> <p>& Loctite 270</p>
<p>Wellenmutter mit Gewindestift</p> <p>Shaft nut with set screw</p>		<p>Gewindesttiff</p> <p>Set screw</p> <p>& Loctite 243 / 262</p> <p>Gewindesttiff nach dem Anziehen ca. 1/2 Umdrehung zurückdrehen Back off set screw 1/2 rotation after tightening</p>
<p>Wellenmutter mit Kontermutter</p> <p>Shaft nut with counter nut</p>		<p>Sicherungsblech & Kontermutter</p> <p>Security spline & counter nut</p> <p>& Loctite 243</p>

Assembly steering cylinder assembly

- Push in the steering cylinder into the steering cylinder brackets .
- Install the bolt .
- Attach the shim and screw on the nut .
- Hand tighten the nut and further tightening to next safety possibility and install the split pin .
- Screw in the grease nipple and lubricate the bearing with bearing grease .

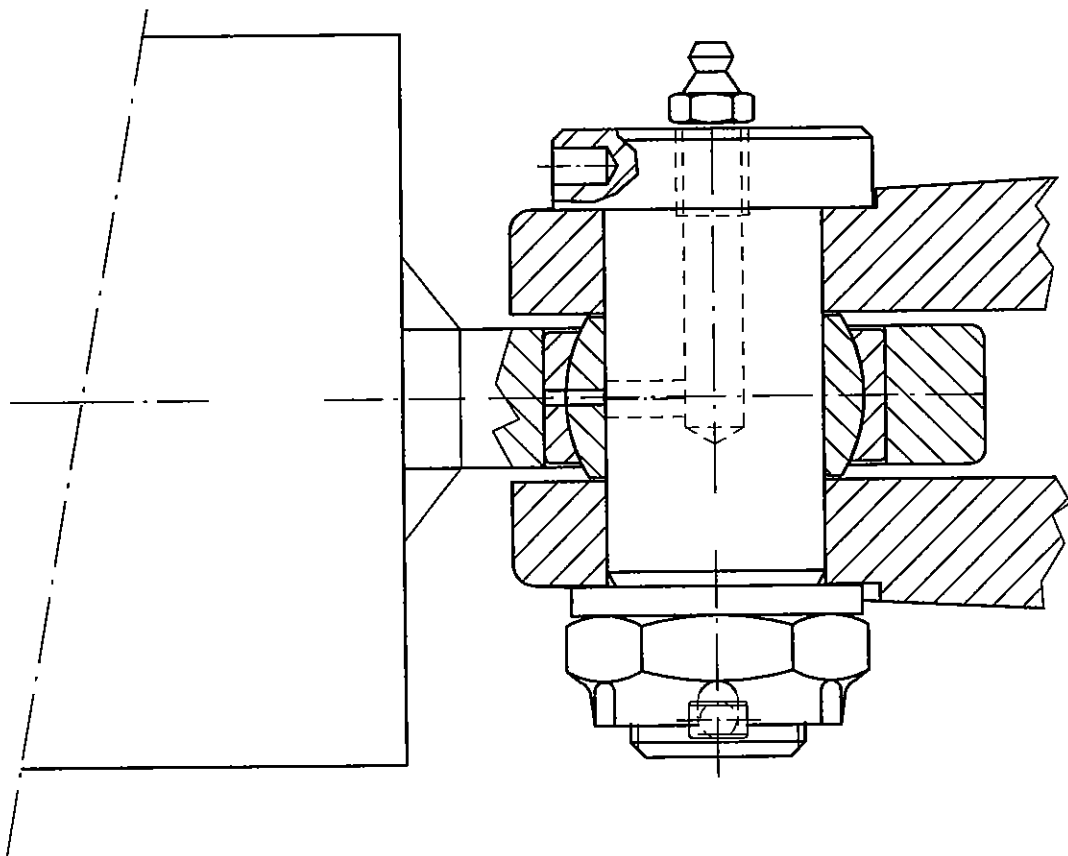

Assembly planetary gear drive

Planetengetriebe
Planetary gear drive

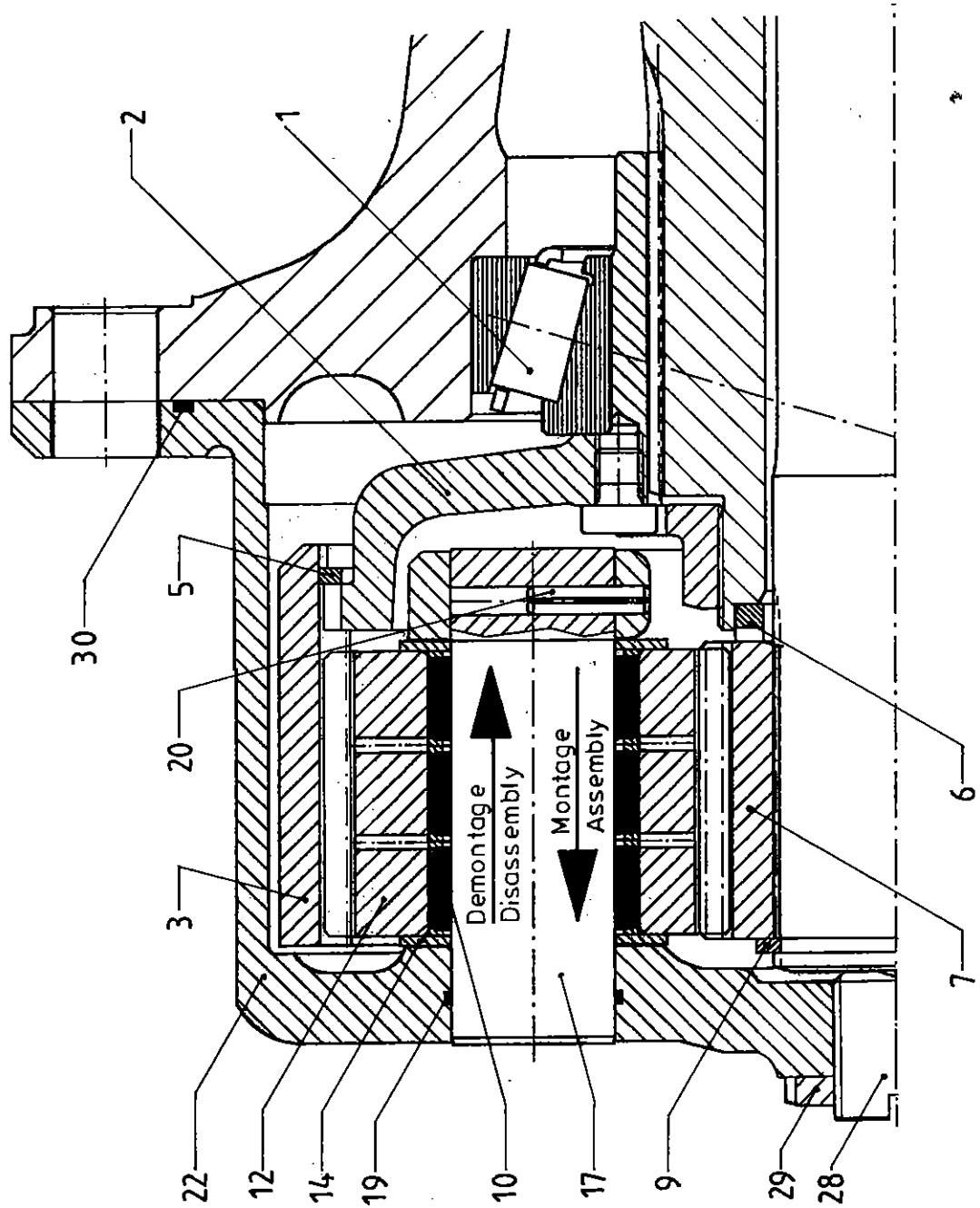

Prepare the ring gear and the ring gear carrier

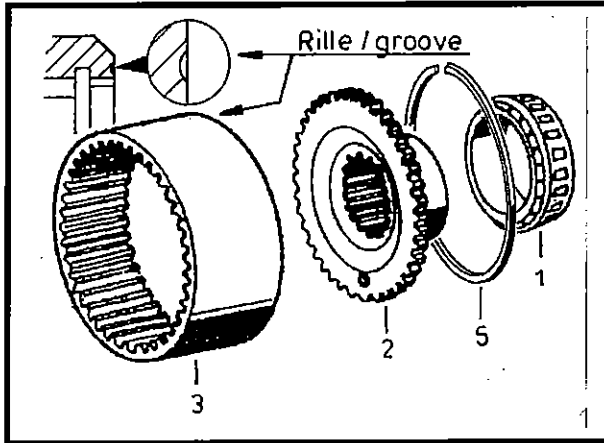

Heat the taper roller bearing inner ring with cage (1) to about 100 ° C and install it onto the ring gear carrier (2) . Place the ring gear (3) onto the ring gear carrier . Install the circlip (5) into the slot of the ring gear .

At planetary gear drive PL 375 and PL 75 pay attention to the marking at the front side of the ring gear :

Ring gear with groove ⇒ circlip SB 250 .

Ring gear without groove ⇒ circlip SB 240 .

Assembly of the ring gear carrier

Install the ring gear carrier (2) with ring gear (3) into the wheel hub resp. onto the steering knuckle resp. axle spindle . The oil compensating hole in the ring gear carrier must be on the bottom . Subsequent adjust wheel bearings (see chapter 5.7) .

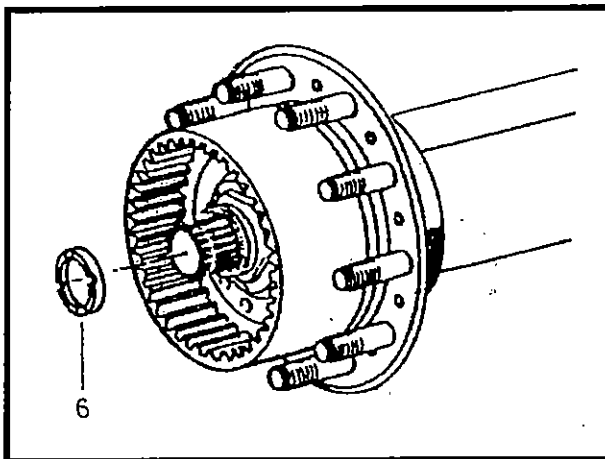

Assembly of the thrust ring

Press the thrust ring (6) into the steering knuckle resp. axle spindle . Secure with Loctite 270 .

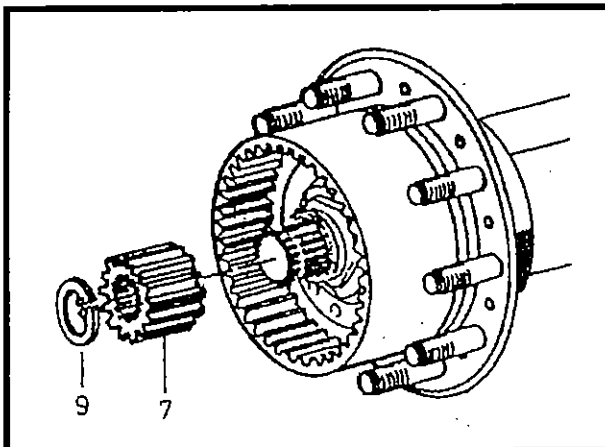

Assembly of the sun gear

Slip the sun gear (7) onto the universal joint resp. axle shaft , install the circlip (9) and push the universal joint resp. axle shaft towards the inside until the circlip contacts to the sun gear and the sun gear contacts to the thrust ring .

Assembly of planetary gear

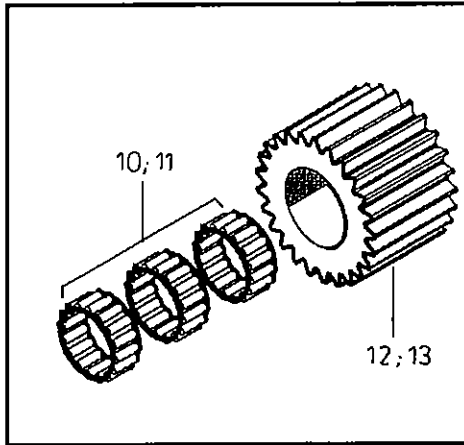

Prepare planetary gear:

Install the needle bearing (10 resp. 11) into the planetary gear (12 resp. 13).

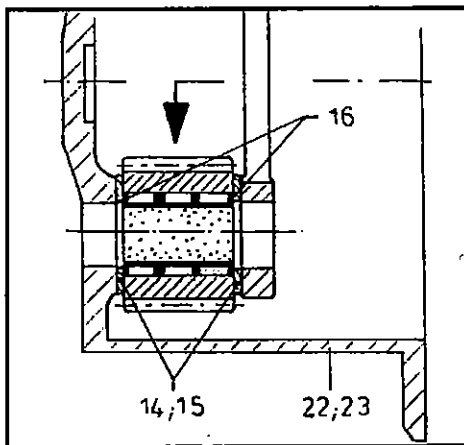

Insert the preassembled planetary gears (12 resp. 13) with needle bearings (10 resp. 11), rings (16) (if present) and thrust disks (14 resp. 15) into the planetary housing (22 resp. 23) (planetary housing in horizontal position).

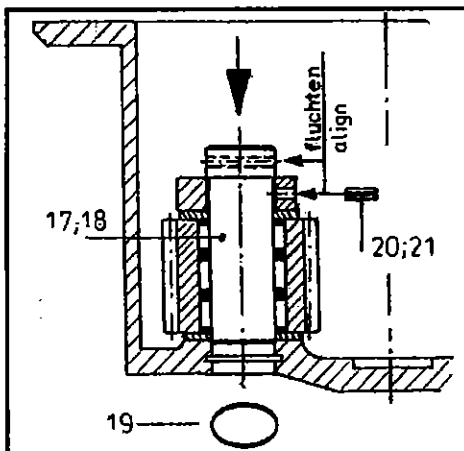

Place o - ring (19) into the slot of the planetary housing (22). Because of the difference of diameter of 0,1 mm press the planetary pin (17 resp. 18) in direction of arrow. Be sure, that the bore hole of the locking pin in the planetary pin and planetary housing are aligned. After inserting, secure the planetary pin with the locking pin (20 resp. 21).

Assembly of the planetary housing

Place o - ring (30) into the slot of the planetary housing . Install the planetary housing and bolt it .

Adjustment of the axial clearance

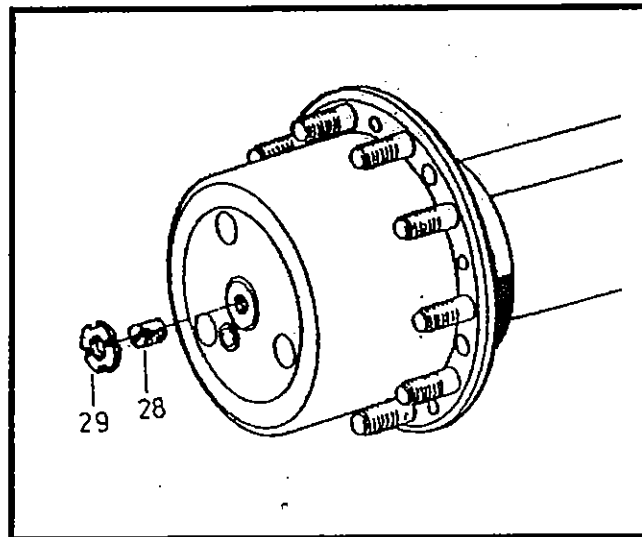

The axial clearance between axle shaft resp. universal joint and adjusting screw must be 0,3 - 0,7 mm .

The adjustment has to be made by screwing in the adjusting screw until it touches the axle shaft resp. universal joint . Back - off the adjusting screw 72 ° - 170 ° from the tightened position (this corresponds to about 0,3 - 0,7 mm axial clearance) .

Secure the adjusting screw and the counter nut with Loctite 270 .

Attention :

When tightening the counter nut (29) , hold the adjusting screw unconditional , to prevent turning of the adjusting screw .

Disassembly of planetary gear

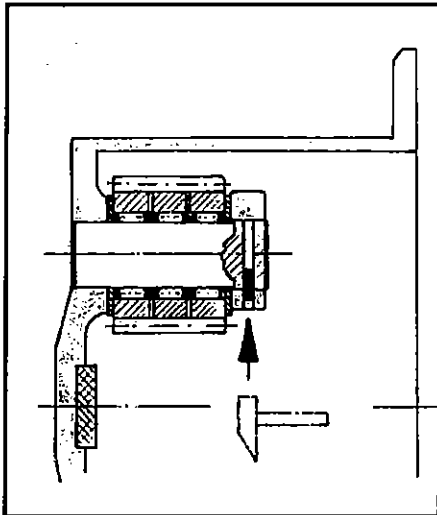

Knock the locking pin (20 resp. 21) completely to the inner side of the planetary pin.

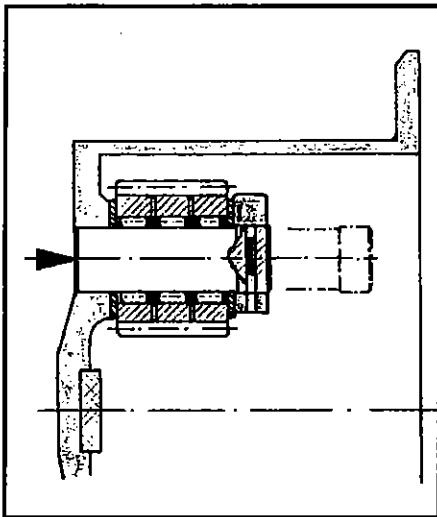

Press the planetary pin in direction of arrow out of the planetary housing.

Attention:

Because of the difference of diameter of 0,1 mm do not press the planetary pin against the direction of arrow out of the planetary housing, to prevent damaging the bore.

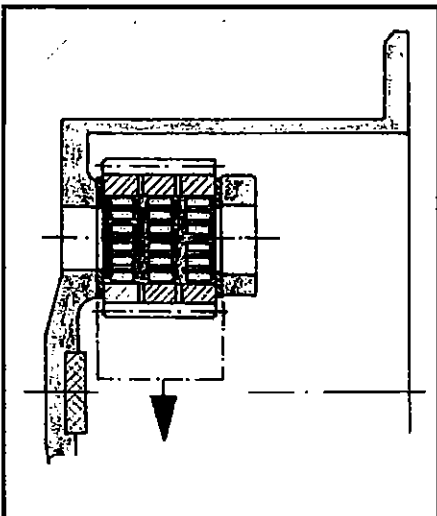

Remove the planetary gears with the thrust disks and needle bearings.

Assembly / disassembly cageless needle bearing (planetary gear bearing)

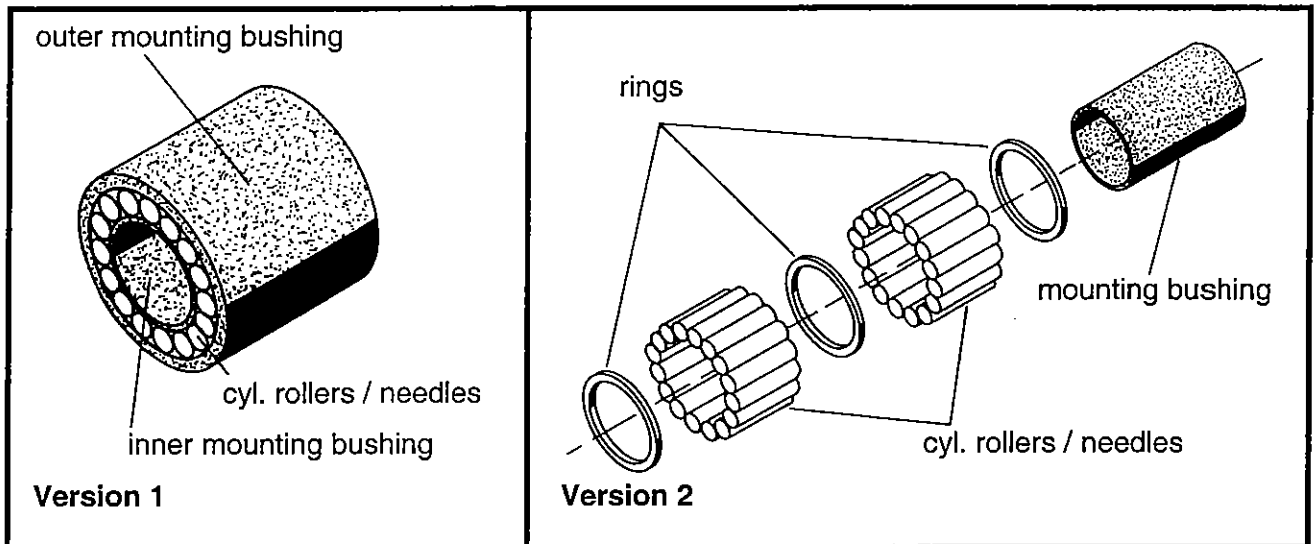

Assembly :

Version 1 : Install the needle bearing with mounting bushings into the planetary gear ; thereby the outer mounting bushing will be stripping .
 Insert the planetary gear with thrust disks into the planetary housing .
 Press in the planetary pin , thereby the inner mounting bushing will remove .

Version 2 : Place one thrust disk on the work bench , place on the planetary gear and insert the mounting bushing .
 Insert the cylindrical rollers / needles alternately with the rings (according to the design) .
 Insert the planetary gear with thrust disks into the planetary housing .
 Press in the planetary pin , thereby the mounting bushing will remove .

Hint : Note the passage " Assembly of the planetary gear " !

Disassembly :

At the disassembly of the planetary pin the cageless needle bearing will fall asunder , if not a mounting bushing will be pushing inwards at planetary pin removing .

Hint : Note the passage " Disassembly of the planetary gear " !

Assembly service brake

Instruction for the servicing and repair of hydraulic - and mechanically actuated drum and disk brakes

1 . General :

Brakes are very important safety components and it is therefore of utmost importance that all service and repair functions be only performed by trained and qualified technicians . Improper adjustment or repairs can lead to brake failure and may ultimately result in property damage , bodily injury , or loss of life .

Vehicles operating on public property are subject to compliance with all applicable federal , state and local ordinances , standards and regulations .

All brake components must be , dependent on usage and operating conditions of the subject vehicle , inspected and , if necessary , repaired or replaced at regularly scheduled intervals in accordance with manufacturer subscribed recommendations and procedures .

Vehicles exempt from the above mentioned regulations must be inspected annually by qualified personnel .

If different braking values are measured by axle on the brake test stand , make the adjustment , in principal , with respect to the brake presenting the best braking action .

2 . Brake lining renewal

Brake linings that are worn , burnt , glazed or contaminated with oil or other lubricants must be replaced at once . It is very important that all brake linings on both brakes of the same axle be replaced simultaneously . Only brake linings or pads recommended and approved by the vehicle manufacturer must be used . In applications where the brake linings are bonded , or bonded and riveted , manufacturers replacement specifications must be followed .

All warranties , expressed or implied , are void and no claim against the manufacturer will be considered if these instructions are not followed .

3 . Other brake components :

Brake shoe return springs , wheel cylinder seals and dust boots and bellows are to be replaced at two year intervals , or sooner if required .

The brake drums and disks wear must not exceed the admissible values .

The brake fluid must conform to specifications SAE J 1703 and safety norms US FMVSS 116 .

Change the operating fluid annually .

When using mineral oil as a operating fluid , provide for the rubber elements resistant to this oil in the brakes and the cylinders .

Important : Using from brake fluid or mineral oil according to the recommendation of the vehicle - or axle - manufacturer . ⇒ Use of improper fluids will affect rubber components of the brake and can cause brake failure !

After having worked on the brakes , purge the air from all of the circuits and verify that there are no leaks .

4 . Burnishing / activating procedure :

Every new brake lining in order to reach optimum performance , must be burnished or activated . This can be accomplished by interval braking in the lower to medium speed ranges of the subject vehicle . Panic stops , or forceful / violent stops are to be avoided . The break in distance , a minimum of 500 km is desirable , is dependent on vehicle design and its intended use . Brake drum / disk temperature must be monitored and can not exceed 200 degrees Celsius .

Temperature rise , as a result of each individual application of the brake must not be more than 15 % of the 200 degree C maximum value .

Burnishing of new brake linings / pads by means of one or more extended applications of the brake or through the performance of several panic stops from high vehicle speeds is not allowed and will void all warranties .

KNOTT

Bremsen

Operating and Maintenance Instructions for
Hydraulic Simplex Brakes

(with automatic friction adjuster)

1. Operating characteristics of the hydraulic simplex brake

The functional characteristics of this brake are based on the movement of the two brake shoes in the brake drum into the contact position after spread of the wheel cylinder.

Determined by the fixed lower support (1), the rising brake shoe (2) (primary shoe) is pressed in the direction of movement against the brake drum, and the downward moving brake shoe (3) (secondary shoe) contrary to the direction of movement against the brake drum.

This configuration ensures that the braking effect is approximately identical in both senses of direction.

Forward movement

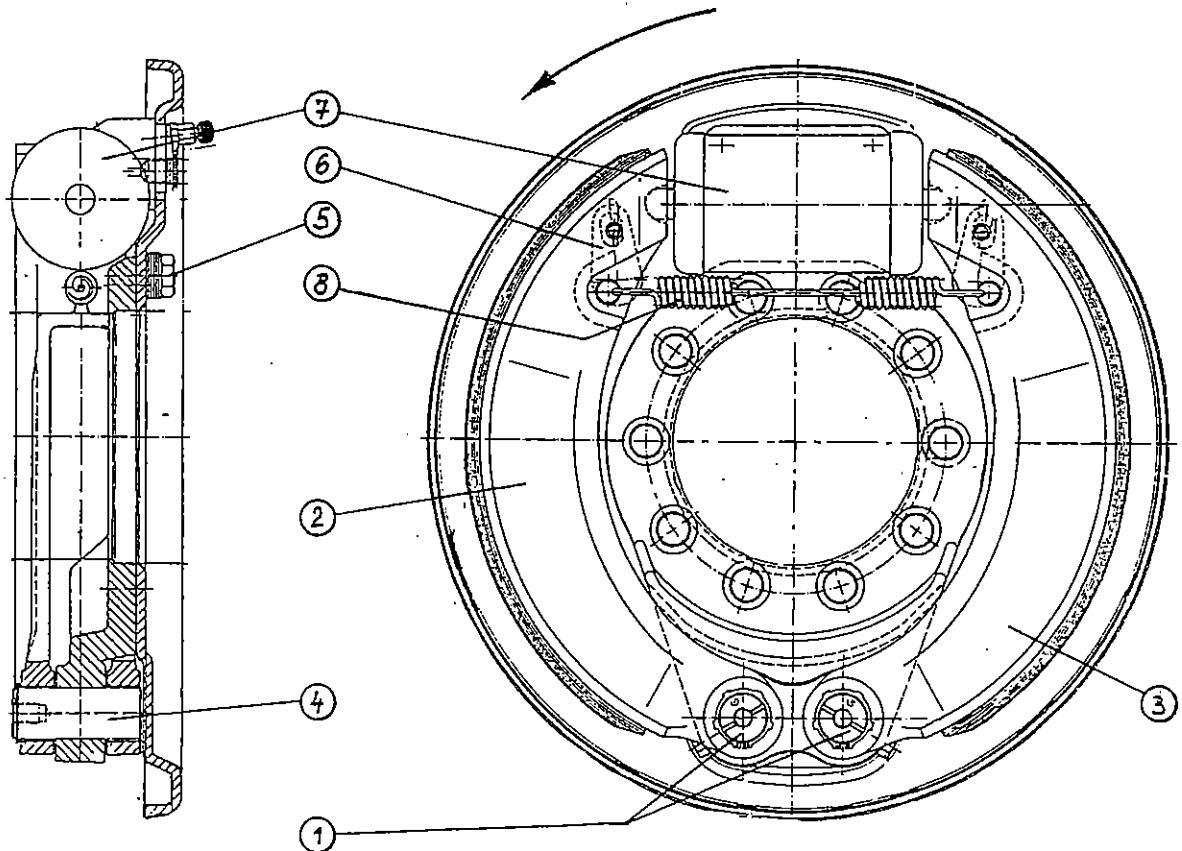

2. Adjuster (automatic friction adjustment)

The brakes are supplied from the factory set ready for installation. The automatic friction adjuster (6) keeps the specified clearance constant over the whole of the permissible lining wear. During repair work on the brake, the brake shoes (2, 3) can be reset by turning a special hexagonal key at the welded hexagonal nuts. This simplifies withdrawal of the brake drum. After completion of work, however, the automatic friction adjuster must be turned far enough to the left or right using the hexagonal screw (5) until the brake shoes come to rest against the brake drum. The two hexagonal nuts (5) are subsequently turned back again far enough to allow the brake drum to run freely. Repair and setting work must be carried out with the axle jacked up.

Pay particular attention to the following: The hexagonal screws (5) of the friction adjusters (6) must remain in the adjusted position and must not be permitted to continue turning or become readjusted under their own volition as a result of the force exerted by the jaw restoring springs (8). Should this case arise, i.e. the existing moment of friction is no longer sufficient, the friction adjuster must be renewed immediately or the brake anchor plate must be completely exchanged (brake anchor plate with cover plate).

3. Wheel cylinder 7

The pressure generated by the actuator is transmitted via the piston of the wheel cylinder to the brake shoe.

3.1 Maintenance

With each periodical brake inspection, the wheel cylinders and their connecting elements must be checked for leaks or areas moistened with oil.

3.2 Repair instruction:

Following dismantling of the cylinder, all individual parts as well as the housing must be subjected to a careful visual inspection. To renew the individual components, repair sets are provided. We would urgently recommend exchanging these as an entire set and not as individual components.

Important Ensure that, where mineral or synthetic brake fluid is used as an operating medium, sufficiently resistant sets of seals are mounted, as otherwise the wheel cylinder will not function correctly.

To clean the cylinder and its individual components, only use methylated spirit. Never under any circumstances use cleaning agents containing mineral oil.

When assembling, ensure that the parts are mounted in the correct order using a suitable assembly paste or fluid.

If defects become evident during visual inspection of the cylinder track in the housing, for example rust scars, grooves or other damage, the wheel cylinder must be exchanged as a complete component. This is available from the respective vehicle or brake manufacturer, specifying the order number.

Once work on the hydraulic system has been completed, check the level of the brake fluid in the storage container and if necessary fill. Then carefully bleed at the main and wheel cylinders in accordance with the instructions of the vehicle manufacturer.

4. Brake shoes

4.1 Maintenance and inspection

The brake shoes themselves are maintenance-free. All that is necessary is to carry out a check for damaged parts, and to check free running at the lower bearing bolt (4). Light lubrication may be necessary using a suitable grease (e.g. Molykote).

The lining thickness must be checked at intervals of no longer than six months, depending on the frequency of use, by means of a visual inspection.

Where the residual lining thickness is too low, these intervals must be reduced accordingly in order to avoid major damage to the brake or brake drum.

As the brake linings can be either glued or riveted types, depending on their application, care should be paid to check for different residual lining thicknesses.

Riveted brake lining: Min. residual thickness 1.0 - 1.5 mm above the rivet head at the thinnest point of the lining

Glued brake lining: Min. residual thickness 2.0 mm at the thinnest point of the lining

Once these thicknesses have been reached, the brake lining must be renewed in accordance with the following regulation:

4.2 Repair / exchange of brake shoes

The brake linings and shoes must be renewed or exchanged if soiled or unevenly worn, or when the braking performance deteriorates, or when the limiting residual thickness has been reached.

Remark: Always renew or exchange all the shoes or linings on one axle in order to avoid the risk of uneven braking behaviour.

Riveted linings can be riveted off and on in accordance with generally applicable regulations by a workshop with the necessary facilities.

Important! However, this must only be done using original spares from the company Knott.
If other spare parts are used, no warranty or guarantee can be accepted on the brakes or their function.

Glued brake linings may only be renewed in the form of a complete exchange of the brake lining.

Remark! A ready-to-install Knott original spare can be supplied for exchange purposes by the vehicle or brake manufacturer, stating the order number.

Important! If other spare parts are used, no warranty or guarantee can be accepted on the brakes or their function.

After mounting or repairing new brake shoes, the brake must be adjusted in accordance with the instructions of the manufacturer Knott.

5. Brake drum

If substantial grooves are in evidence on the drum running surface during a regular inspection, the brake drum can be turned in accordance with the instructions of the vehicle manufacturer.

If no instructions are provided here, proceed in accordance with the following table, taking the thickness of the walls into consideration.

Max. permissible turning dimensions for brake drums

Brake size	Drum dia. [mm]	Max. turning dia. [mm]
325 x 80	325.0	327.5
400 x 80	400.0	403.0
500 x 120	500.0	504.0

Particular attention must be paid here to ensure that both the brake drums of a particular axis are reworked to the same dimension.

Remark: For reworked brake drums, outsize brake lining thicknesses should be used.

6. General:

Any defects or damage discovered on parts not listed here must naturally be repaired or replaced using original spares.

Any missing specifications or more detailed instructions can be provided by the vehicle or brake manufacturer.