

ALL SPECIFICATIONS SUBJECT TO CHANGE WITHOUT NOTICE

FEATURE	DESCRIPTION	SPECIFICATION
Capacity	Minimum Body Volume	15-1/4 cu yd (11-3/4 cu m)
	Front Compartment	6-1/2 cu yd (5 cu m)
	Rear Compartment	8-3/4 cu yd (6-3/4 cu m)
	Net Body Weight	5100lbs (2310kg)
	Each Bucket Volume	1/2 cu yd (3/8 cu m)
	Each Bucket Capacity Weight	500lbs (225kg)
Construction	Side Panel	14 Ga. (1.9mm) Formed Steel
	Floor	10 Ga. (3.4mm) Formed Steel
	Frame	10 Ga. (3.4mm) HSS Tubing
	Rockershaft	Re-inforced Heavy Duty Pipe
Hydraulic System		
Hoist Capacity	Double Acting Cyl 45° Dump Angle	5tons (4-1/2tonnes)
PTO/Pump	Output @ 1200 RPM	10gpm (38 l/min)
Hyd Valve	5 spool Directional Control	
	Rated Operating Pressure	3000psi (200bars)
	Capacity	15 us gpm (56 l/min)
Load & Pack Cycle	Varies with chassis	15 sec @ 1200 RPM

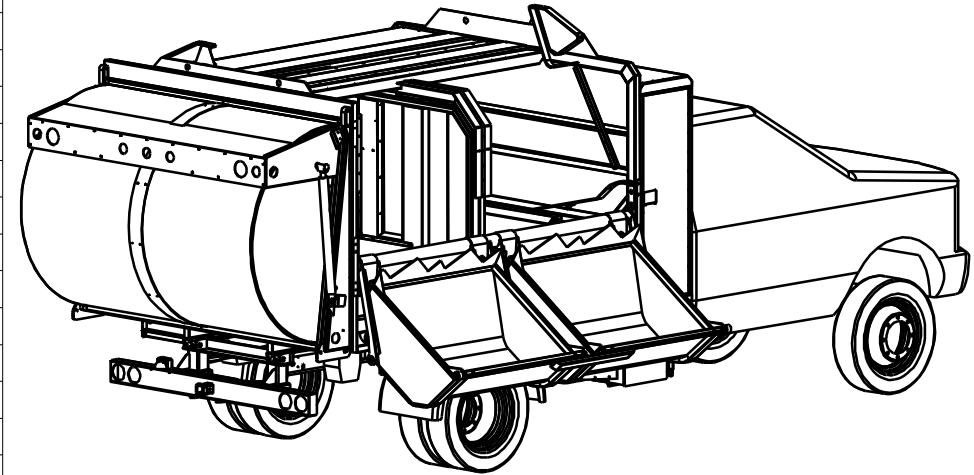

* SPECIFICATIONS & DIMENSIONS ARE BASED ON A TYPICAL CHASSIS AND MAY VARY

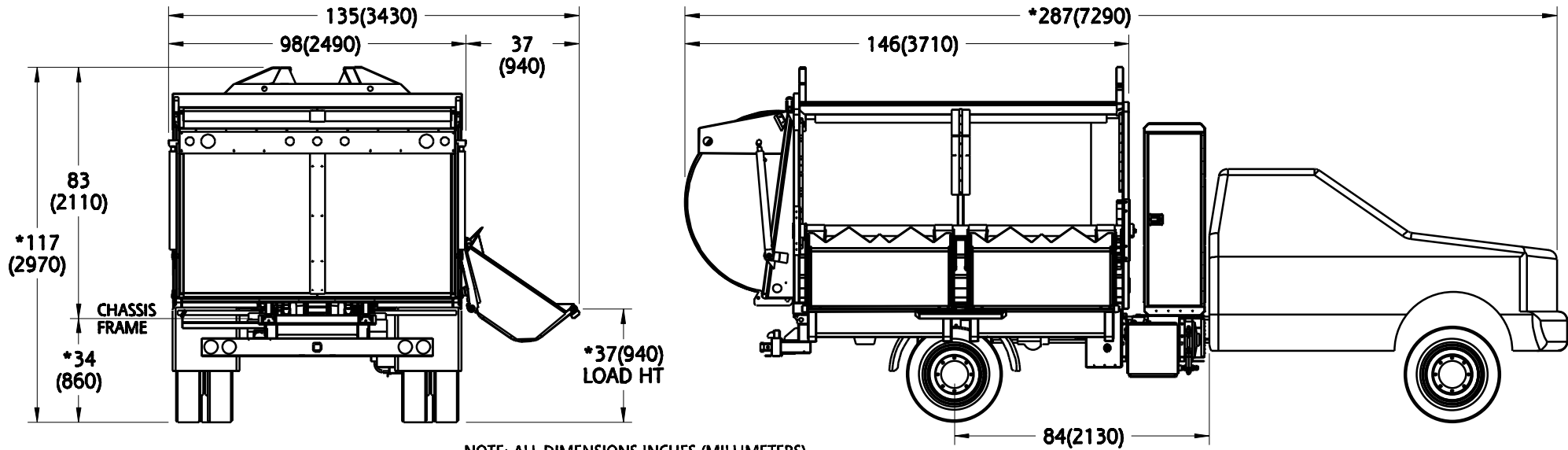

NOTE: ALL DIMENSIONS INCHES (MILLIMETERS)

CHASSIS REQUIREMENTS	SPECIFICATION
*Gross Vehicle Weight	19500lbs (8850kg)
Minimum CA Distance	84in (2130mm)
*Rear Axle Rating	13500lbs (6120kg)
*Front Axle Rating	6000lbs (2720kg)

HAUL-ALL EQUIPMENT LTD. reserves proprietary rights on this drawing or any part of the information contained thereon. This drawing shall be considered confidential material and is not to be used for competitive bidding nor for use in any procurements other than from Haul-All Equipment Ltd.



NAME M-CLASS 1600 RH BUCKET SPLIT BODY		
PART NUMBER	SP-M1600S	DRAWN BY PS
DATE	FEBRUARY 11, 2010	REVISION 1