

ALL SPECIFICATIONS SUBJECT TO CHANGE WITHOUT NOTICE

FEATURE	DESCRIPTION	SPECIFICATION
Capacity	(1) 65 Gal Wheeled Poly-Cart	8-3/4 cu.ft. 65 US Gallons (246L)
	(1) 95 Gal Wheeled Poly-Cart	12-3/4 cu. ft. 95 US Gallons (360L)
Construction	Housing	14 Ga. (1.9) Galvanneal Steel
	Lid	12 Ga. (2.6) Galvanneal Steel
	Floor	10 Ga. (2.6) Stainless Steel
	User Door	14 Ga. (1.9) Galvanneal Steel
	Side Hinged Unloading Door	14 Ga. (2.6 Galvanneal Steel
	Hinges and Latches	Stainless Steel
	Paint	Powder Coat
Weights	Hid-A-Cart Container	310lbs (140kg)
	(Optional) with Pre-Cast Mounting Pad	525lbs (240kg) 40x36x4 (1015x915x102)

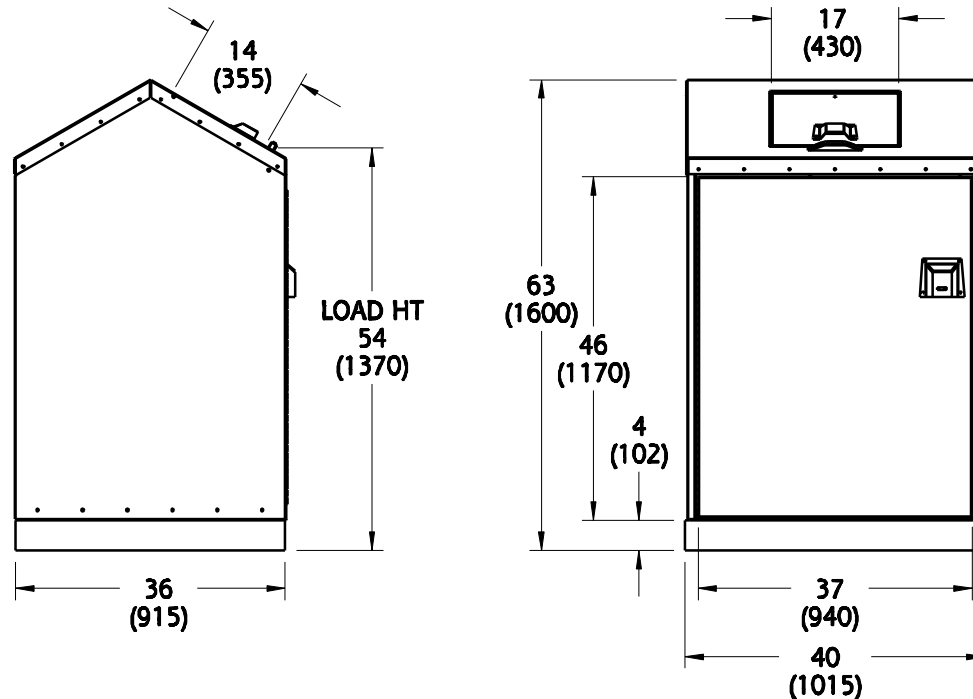
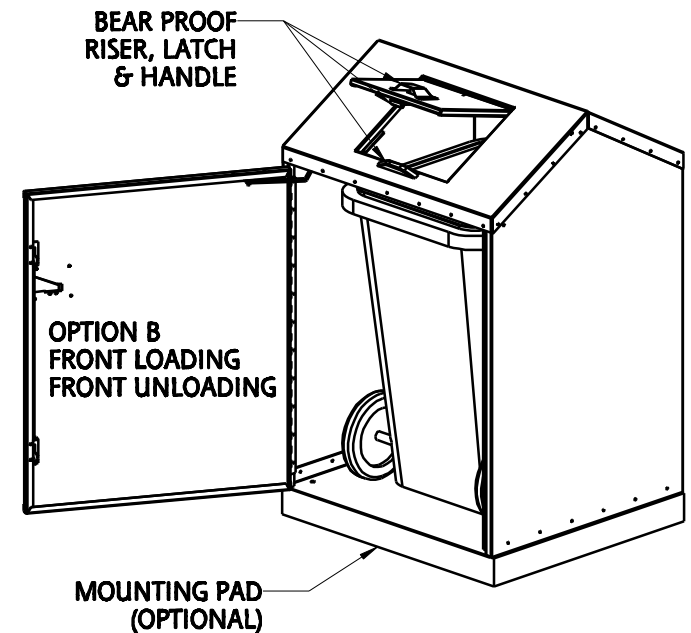
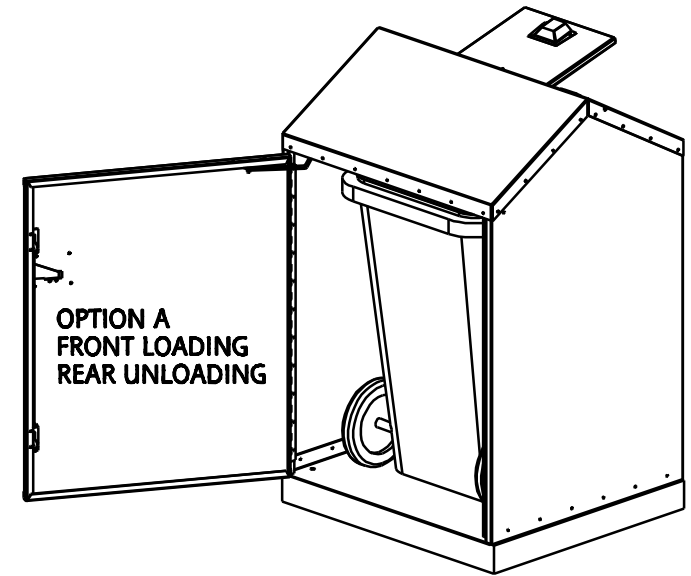

NOTE: ALL DIMENSIONS INCHES (MILLIMETERS)

TRAILER SIZE	QTY
8-1/2ft x 45ft	39
8-1/2ft x 53ft	45
B-Train 8-1/2ft x 28ft & 32ft	60
Double Decker Van 8-1/2ft x 48ft	112

HAUL-ALL EQUIPMENT LTD. reserves proprietary rights on this drawing or any part of the information contained thereon. This drawing shall be considered confidential material and is not to be used for competitive bidding nor for use in any procurements other than from Haul-All Equipment Ltd.



NAME	
SINGLE HID-A-CART BP CONTAINER	
PART NUMBER	SP-HC1-P
DATE	MARCH 18, 2010
DRAWN BY	PS
REVISION	1

ALL SPECIFICATIONS SUBJECT TO CHANGE WITHOUT NOTICE

FEATURE	DESCRIPTION	SPECIFICATION
Capacity	(1) 65 Gal Wheeled Poly-Cart	8-3/4 cu.ft. 65 US Gallons (246L)
	or (1) 95 Gal Wheeled Poly-Cart	12-3/4 cu. ft. 95 US Gallons (360L)
Construction	Housing	14 Ga. (1.9) Galvanneal Steel
	Lid	12 Ga. (2.6) Galvanneal Steel
	Floor	10 Ga. (2.6) Stainless Steel
	User Door	14 Ga. (1.9) Galvanneal Steel
	Side Hinged Unloading Door	14 Ga. (2.6) Galvanneal Steel
	Hinges and Latches	Stainless Steel
	Paint	Powder Coat
Weights	Hid-A-Cart Container	310lbs (140kg)
	(Optional) with Pre-Cast Mounting Pad	525lbs (240kg) 40x36x4 (1015x915x102)
	(Optional) Front Step Kit	105lbs (48kg) Kit weight only

BEAR PROOF RISER LATCH & HANDLE

OPTIONAL FRONT STEP c/w SAFETY GRATE

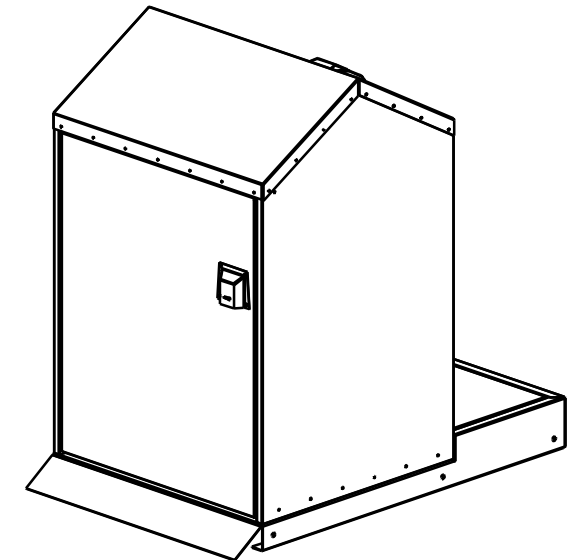
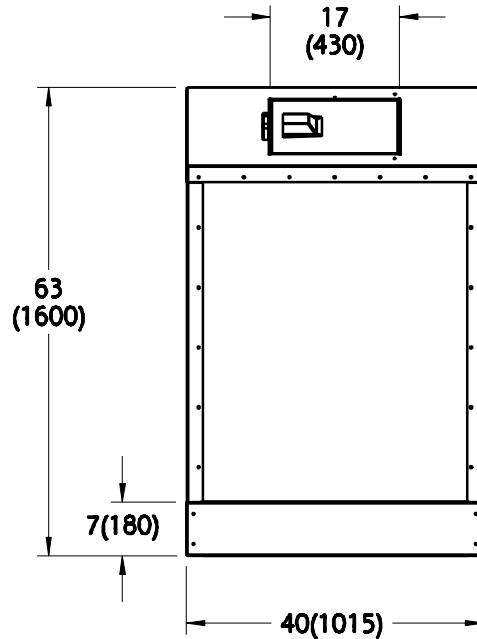
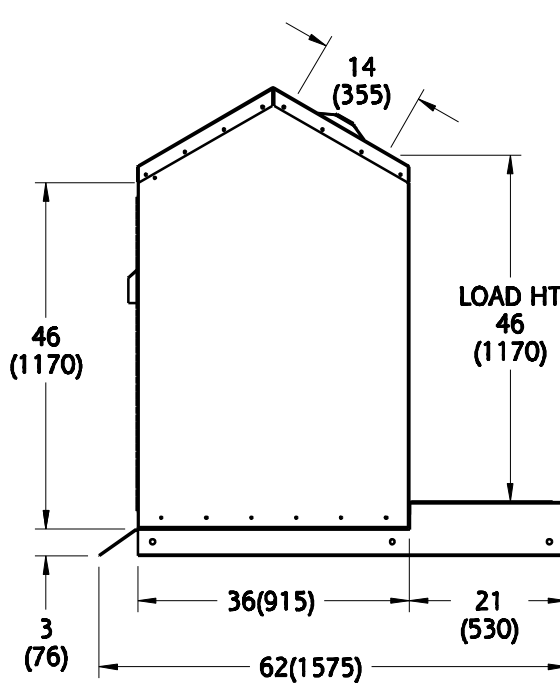
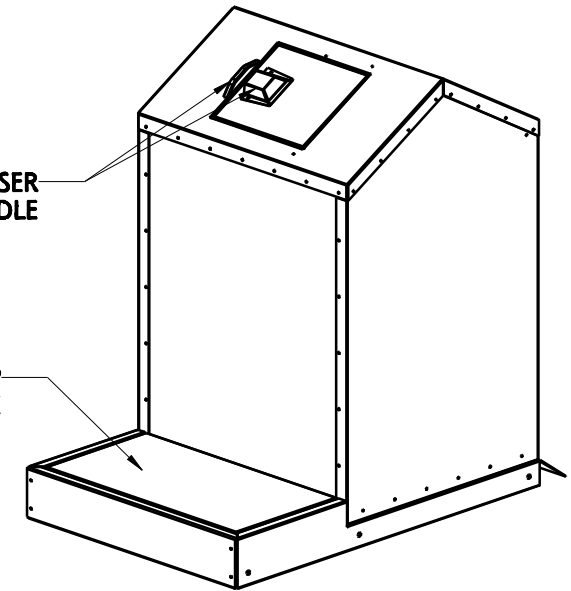

NOTE: ALL DIMENSIONS INCHES (MILLIMETERS)

TRAILER SIZE	QTY
8-1/2ft x 45ft	39
8-1/2ft x 53ft	45
B-Train 8-1/2ft x 28ft & 32ft	60
Double Decker Van 8-1/2ft x 48ft	112

HAUL-ALL EQUIPMENT LTD. reserves proprietary rights on this drawing or any part of the information contained thereon. This drawing shall be considered confidential material and is not to be used for competitive bidding nor for use in any procurements other than from Haul-All Equipment Ltd.



NAME SINGLE HID-A-CART BP CONTAINER		
PART NUMBER	SP-HC1-P-SIDE	DRAWN BY PS
DATE	APRIL 19, 2011	REVISION 1