

M-215-16

with RC 36 Controller

S/N K6975 and Up

Updated August 7, 2018



Computerized Variable Width Hopper **CHIPSREADER**



Operation



Maintenance



Safety

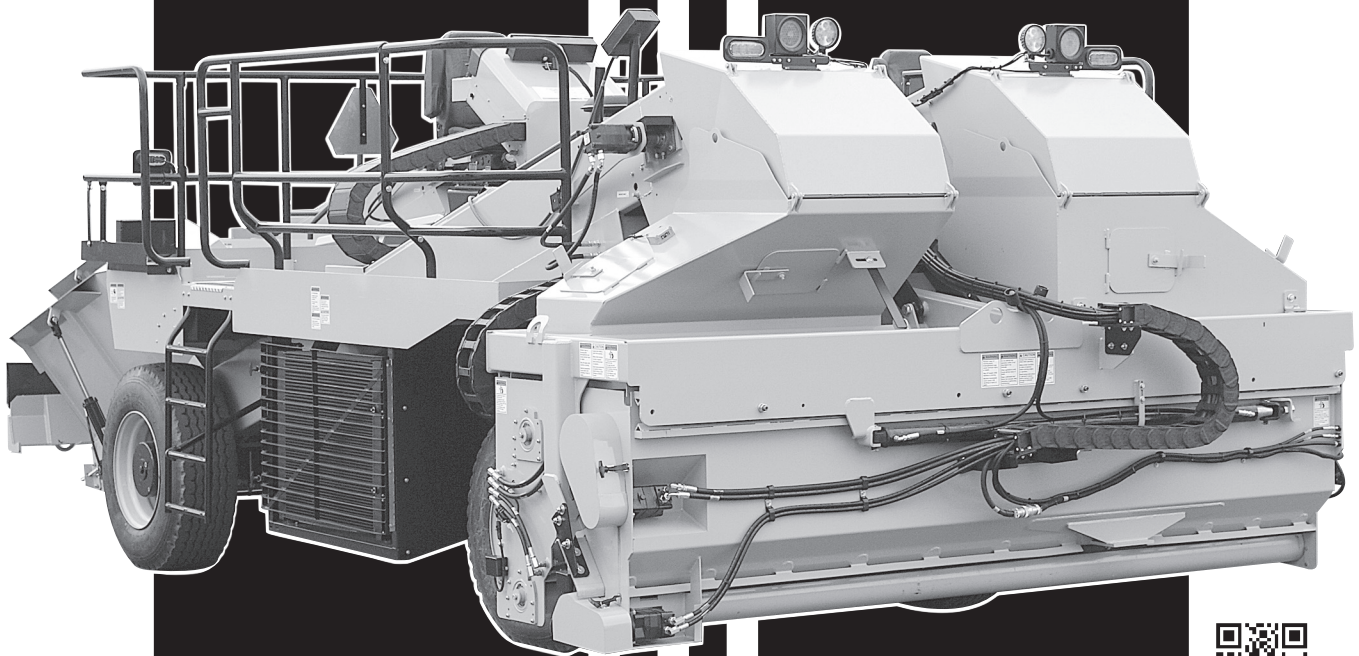

E. D. ETNYRE & CO. 1333 S. Daysville Road, Oregon, Illinois 61061

Phone: 815/732-2116 or 800/995-2116 • Fax: 800-521-1107 • www.etnyre.com

M-215-16

**Computerized Variable Width Hopper
ChipSpreader**

with RC 36 Controller

S/N K6975 & Up

Updated August 7, 2018

Operation, Maintenance and Safety Manual

WARRANTY

E. D. Etnyre Co. warrants to the original Purchaser, its new product to be free from defects in material and workmanship for a period of twelve (12) months after date of delivery to original Purchaser. The obligation of the Company is limited to repairing or replacing any defective part returned to the Company and will not be responsible for consequential damages or any further loss by reason of such defect.

The company excludes all implied warranties of merchantability and fitness for a particular purpose. There are no warranties, express or implied, which extend beyond the description of the goods contained in this contract.

This warranty does not obligate the Company to bear the cost of machine transportation in connection with the replacement or repair of defective parts, nor does it guarantee repair or replacement of any parts on which unauthorized repairs or alterations have been made or for components not manufactured by the Company except to the extent of the warranty given by the original Manufacturer.

This warranty does not apply to:

- (1) Normal start-up services, normal maintenance services or adjustments usually performed by the selling dealer, factory service representative or customer personnel.
- (2) Any product manufactured by E. D. Etnyre Co. purchased or subjected to rental use.
- (3) Any product or part thereof which shows improper operation, improper maintenance, abuse, neglect, damage or modification after shipment from factory.
- (4) Any product or part thereof damaged or lost in shipment. Inspection for damage should be made before acceptance or signing any delivery documents releasing responsibility of the delivering carrier.

This warranty and foregoing obligations are in lieu of all other obligations and liabilities including negligence and all warranties of merchantability or otherwise, express or implied in fact or by law.



E. D. ETNYRE & CO., Oregon, Illinois 61061-9778

1333 South Daysville Road Phone: 800-995-2116 Fax: 800-521-1107

www.etnyre.com

Safety Precautions, Hazard Seriousness Level

You will find safety information boxes throughout this manual. These boxes contain information alerting you to situations or actions to avoid.

Signal words (DANGER, WARNING and CAUTION) are used to identify levels of hazard seriousness. Their selection is based on the likely consequence of human interaction with a hazard. Definitions of hazard levels are as follows.

 **DANGER** - Immediate hazards which **will** result in severe personal injury or death.

 **WARNING** - Hazards or unsafe practices which **could** result in severe personal injury or death.

 **CAUTION** - Hazards or unsafe practices which could result in minor personal injury or product or property damage.

CALIFORNIA

Proposition 65 WARNING

Diesel engine exhaust and some of its constituents are known to the State of California to cause cancer, birth defects, and other reproductive harm.

Please note this warning and remember -
Always start and operate the engine in a well ventilated area;
If in an enclosed area, vent the exhaust to the outside;
Do not modify or tamper with the exhaust system.

CAUTION

Before breaking the seal on all hydraulic fittings, fill caps, etc. be sure to clean around the connection. Failure to do so may cause contaminants to enter the hydraulic system causing damage to pumps, motors, etc.

WARNING

Do not use this machine for any operation which is not described in this manual.

If you have any questions about operation of this machine, contact the Etnyre Service Department at
1-800-995-2116 or 1-815-732-2116.

Operations that are not approved could cause serious injury or death.

WARNING

FLUROELASTOMER HANDLING

Some O-rings and seals used in this vehicle are made from fluoroelastomers. When used under design conditions, fluoroelastomers do not require special handling. However, when fluoroelastomers are heated to temperatures beyond their design temperature (around 600° Fahrenheit), decomposition may occur with the formation of hydrofluoric acid. Hydrofluoric acid can be extremely corrosive to human tissue if not handled properly.

A degraded seal may appear as a charred or black sticky mass, Do not touch either the seal or the surrounding equipment without wearing neoprene or PVC gloves if degradation is suspected. Wash parts and equipment with 10% lime water (calcium hydroxide solution) to neutralize any hydrofluoric acid.

If contact with the skin occurs, wash the affected areas immediately with water. Then rub a 2.5 calcium gluconate gel into the skin until there is no further irritation, while seeking prompt medical attention.

Note to Physicians: For advice or treatment of HF burns, call the DuPont Medical Emergency number, 1-800-441-3637

Table Of Contents

WARRANTY	1
List of Illustrations.....	4
 GENERAL	
General Identification.....	5
INTRODUCTION	
Reporting Safety Defects.....	6
Check Out.....	6
 OPERATION	
Identification and Function of Controls	8
Power/Ignition Switch.	8
Mode Selector-Drive/Park	8
Speed Set Toggle Switch.....	8
Aggregate Size Switch.....	9
Application Rate Switch.....	9
Circuit Breakers.	10
Computer Display Screen.	10
MATERIAL CALIBRATION.....	10
Screen Scroll Switch.....	12
Speed/Direction Control Handle (Figure 2)	13
Gate/Spread Roll Switch (Figure 2).....	13
Turn Signal Selector and Indicators. (Figure 4)	14
Hazard Flasher Switch (Figure 4).....	14
Headlight Switch. (Figure 4)	14
Seat Shift Switch. (Figure4) (Optional)	14
Hitch Release Pushbutton. (Figure 4)	14
Strobe Switch. (Optional).....	14
Application Rate Computer. (inside control panel).....	14
Right Conveyor Selector.....	15
Left Conveyor Selector.	15
Hitch Height Switch.	15
Left Gate Override Switch	15
Right Gate Override Switch	15
Left Hopper Position Switch	15
Right Hopper Position Switch	15
Left Gate Power Switch	15
Left Spread Roll Switch	15
Right Gate Power Switch.....	15
Right Spread Roll Switch	15
Left Auger Selector	15
Right Auger Selector	16
Memory Selector Buttons	16
Memory Save Button.....	16
Calibrate Switch.....	16
Traction Control Switch.....	16
Throttle Run/Idle Switch	16
Throttle Increase/Decrease Switch.....	16
Horn.....	16
Batwing Switch	16
Warning Light	16
Filter Indicator.....	16
Auxiliary 12 Volt Power	16
Engine Diagnostics On/Off Switch.....	16
Vibrator Auto Select Switch (Optional)	16
Vibrator Manual On/Off Switch (Optional)	16
Engine Diagnostics Stop Light	16
Engine Diagnostics Warning Light.....	17
Emergency Stop Switch	17
Computer Reset Switch.....	17
Individual Gates Master Switch	17
Left Hopper Gate Selector Switches	17
Right Hopper Gate Selector Switches	17
Hopper Raise/Lower Switch	17
Traction Boost switch (Optional).....	17
Brake Pedal (figure 4)	17
Left and Right Hopper Switch (figure 7)	18
Left and Right Conveyor Pushbutton (figure 7)	18
Hitch Release Pushbutton (figure 7)	18
Left and Right Auger Pushbutton (figure 7)	18
Left and Right Gate Override Switch (figure 7).....	18
Operation	19
Automatic Conveyor Control (figure 1)	20
Ultrasonic Sensors	20
Backup Alarm	20
Hydraulic Powered Seat Assembly.....	20
Individual Gates (figure 10)	20
Towing Instructions	21
 MAINTENANCE	
APPENDIX A.....	22
MAINTENANCE ADJUSTMENTS	22
Hopper Spread Roll Wear Plate Adjustment	22
Hopper Gate Wear Plate Adjustment	22
Conveyor Belt Adjustment	22
APPENDIX B.....	24
COMPUTER SETUP	24
Computer Set Up.....	24
Set Up Screens	24
APPENDIX C.....	27
COMPUTER SERVICE SCREENS.....	27
APPENDIX D.....	31
SYSTEMS STARTUP AND ADJUSTMENTS	31
Hydrostatic System Startup	31
Gate Transducer Adjustment	32
Air Pressure Adjustments	33
Pressure Settings For Hydrostatic Drive Pump	33
Setting the Charge Pressure	35
Pressure Settings For Auxiliary Pumps (Rexroth A10VO74 and AA10VO100D).....	35
Relief Valve Settings	35
Setting the Front Pump.....	35
Setting the Rear Pump	36
Pressure/Flow Settings For Actuator Valving	37
Hopper Reducing Valves	37
Spreadroll Speed Adjustment.....	38
Right Spreadroll.....	38
Left Spreadroll	38
Fixed Displacement Auxiliary Pump	38
Pressure Settings For Actuator Valving Supplied By Rear Auxiliary Pump	39
Main Relief Pressure (MPT)	39
Pilot Pressure (PP)	39
Fan Valve Pressure Setting	39
Truck Hitch Arrangement.....	40
LUBRICATION.....	41
CAUTION AND INSTRUCTION PLATES.....	42
COMMENT FORM	43

List of Illustrations

Figure 1. Control Panel Identification	9
Figure 2. Speed/Direction Control Handle.....	13
Figure 3. Ground Speed Pickup	14
Figure 4. Control Panel.....	14
Figure 6. Auger Auto On/Off Switch.....	18
Figure 7. Front Operator's Control Panel	18
Figure 8. Conveyor Diaphragm Switches	20
Figure 10. Individual Gates.....	21
Figure 11. Spread Roll Wear Plate	22
Figure 12. Hopper Gate Wear Plate	22
Figure 13. Conveyor Tail Pulley.....	23
Figure 14. Conveyor Head Pulley Adjustment.....	23
Figure 15. Hydrostatic Pump	31
Figure 16. Engine Left Side	31
Figure 17. Gate Valve	32
Figure 18. Gate/Hopper/Conveyor/ Auger/Spreadroll Manifolds	33
Figure 19. Right Gate Solenoid	33
Figure 20. Left Hopper Transducer.....	33
Figure 21. Air System	33
Figure 22. POR Setting	34
Figure 23. High Pressure Relief Setting	34
Figure 24. Charge Pressure Adjustment	35
Figure 25. Conveyor/Auger/Spreadroll Manifold	36
Figure 26. Pumps	36
Figure 27. Gate/Hopper Manifolds	36
Figure 28. Gate/Hopper/Conveyor/ Auger/Spreadroll Manifolds	37
Figure 29. Hopper/Gate Manifold	37
Figure 30. Conveyor/Auger/Spreadroll Manifold	38
Figure 31. Spreadroll Speed Adjustment.....	38
Figure 33. Hydraulic Control Assembly	39
Figure 34. Fan Valve	39
Figure 36. Engine Belt Routing	38

General Identification

- 1 Conveyor Drive Motor
- 2 Head Pulley Asm
- 3 Gate/Hopper Manifold
- 4 Conveyor/Auger/Spreadroll Manifold
- 5 Return Filters
- 6 Front Drive Axle
- 7 Air Reservoir
- 8 Hydrostatic Motor
- 9 Tail Pulley Asm
- 10 Radiator Cooler
- 11 Suction Line to Pumps
- 12 Hitch/Pwr Steer/Brake Manifold
- 13 Hydraulic Pumps
- 14 Horn
- 15 Rear Drive Axle
- 16 Rear Hydrostatic Motor
- 17 Hitch Position Linkage
- 18 Conveyor Belt
- 19 Hoods
- 20 Left Head Light Asm
Right Head Light Asm
- 21 Engine/Conveyor Covers/Decking
- 22 Hydraulic Reservoir
- 23 Front Control Box Asm
- 24 Left Spread Hopper
- 25 Individual Gate Cylinders
- 26 Air Intake Asm
- 27 Rough Tread
- 28 Control Console Asm
- 29 Seat Assembly
- 30 Handrails
- 31 Slow Moving Emblem
- 32 Right Tail light Asm
Left Tail light Asm
- 33 Rear Hopper Flow Gate
- 34 Flashing
- 35 Rear Lining
- 36 Hitch
- 37 Rear Motor Access Panel
- 38 Back Up Alarm
- 39 Fuel Tank

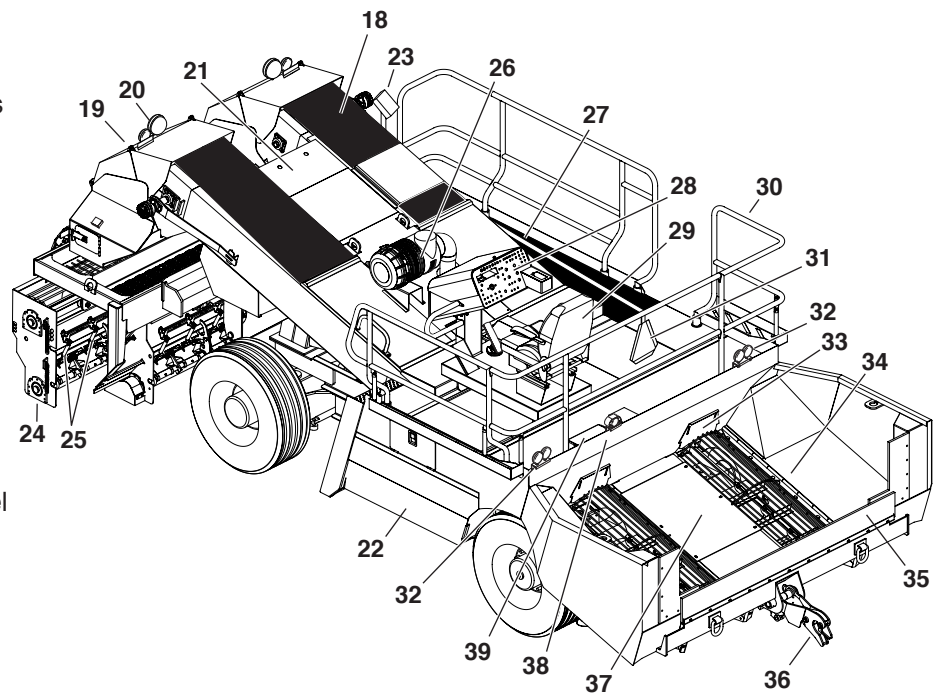
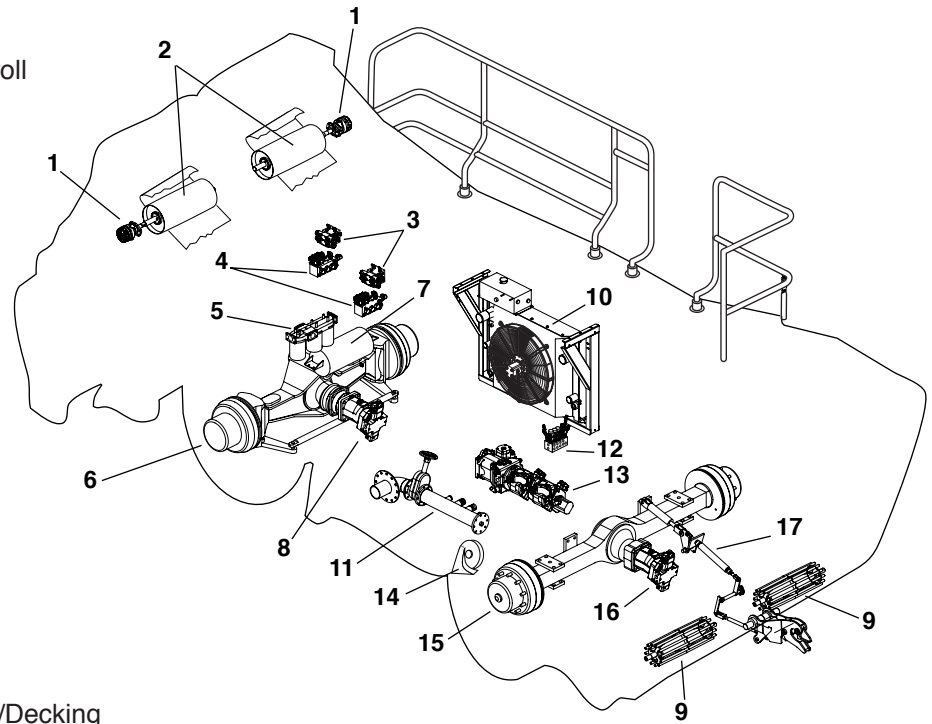

INTRODUCTION

The Etnyre Variable Hopper Hydrostatic Chipsreader has been designed to improve the accuracy of chip spreading while improving productivity. This has been done by incorporating Application Rate capabilities using precise gate opening control and speed feedback in closed loop controls, and the ability to do most roads in a single pass.

It is especially important from the safety standpoint that this manual be thoroughly read and understood before performing any operational or maintenance function.

The information contained in this manual will enable you to better understand the operation and performance of the machine and thus better utilize it to obtain maximum performance from your Chipsreader.



WARNING

Unsafe operation of equipment may cause injury. Read, understand and follow the manuals when operating or performing maintenance

IMPORTANT

1. The front hoppers should be fully closed up and latched using the safety chains on the left side of the machine when the unit is traveling between job sites to avoid possible damage to the outer ends of the hoppers.

2. Keep machine on road or relatively uniform surface at all times to avoid loss of traction and/or possible damage to the front hoppers or rear of conveyors.

3. Place truck gearshift in neutral as soon as the truck is connected to the spreader.

4. Under most operating conditions the Chipsreader should be allowed to tow the truck. However, certain steep upgrade or downgrade conditions may require the truck to assist the Chipsreader. The Chipsreader must pull the truck even while the truck is assisting. Do not attempt to push the Chipsreader with the truck.

5. Do not tow or push the Chipsreader before reading the towing instructions contained in this manual as this may damage the hydraulic motors.

6. Never use the Chipsreader to dislodge a truck or other equipment which has become stuck in mud or soft shoulder conditions as this may cause damage to the hitch, which could fail later in normal operation.

7. Avoid roading the machine with material in the hoppers if at all possible. Added weight in either the front hoppers or the rear hopper increases stopping distance, and weight in the front hopper decreases available traction at the rear wheels.

8. After changing filters or working on the hydrostatic system, be sure to follow hydrostatic start up procedure to reduce the potential for damage to the hydrostatic system.

9. Always install locking control box cover & chock wheels when leaving machine unattended as protection against vandalism and accidental movement.

10. Before operating the Chipsreader, do an inspection of the machine for condition of the tires, fluid leaks, fluid levels, fuel level, loose bolts, improper hose routings etc. Be sure that the machine is in a safe condition to operate.



CAUTION

The front hoppers should be fully closed up and latched using the safety chains at the left side of the machine when the unit is traveling between job sites to avoid possible damage to the outer ends of the hoppers.

Reporting Safety Defects

If you believe that your vehicle has a defect which could cause a crash or could cause injury or death you should immediately inform the National Highway Traffic Safety Administration (NHTSA) in addition to notifying E. D. Etnyre & Co.

If NHTSA receives similar complaints, it may open an investigation, and if it finds that a safety defect exists in a group of vehicles, it may order a recall and remedy campaign. However, NHTSA cannot become involved in individual problems between you, your dealer, and E. D. Etnyre & Co.

Check Out

1. The following accessories are shipped with each Chipsreader: extra linkage rods for shortened truck hookup, parts book and operation, maintenance and safety manual, wiring and hydraulic diagrams, and engine parts and operator's manual.

2. Best performance for most operating conditions is achieved when tire pressures are set to 55 to 60 PSI

in front and 60 to 65 PSI in rear. However, various operating speeds, road bed conditions, truck pulling arrangements and other operating conditions may require different tire pressures.

 WARNING
Never exceed the maximum inflation pressures indicated on the tire's sidewall.

3. Grease all fittings and check all reservoir oil levels in accordance with the Chipspreader Lubrication Chart on the side of the tool box prior to operation.

4. Check engine coolant and oil levels prior to operation. Refer to engine operator's maintenance manual for complete engine service requirements.

5. Hopper gate adjustment and spread roll straightness are established at the factory. However, to be sure adjustments or straightness were not altered during shipment and storage, the following gate and spread roll adjustment checks should be performed prior to operation:

Check that each gate opening cylinder rod clevis is fully screwed onto its respective cylinder rod.

With the hopper on the machine, start the engine and run it at a minimum of 2000 rpm and extend the hoppers fully. Depress and hold the left and right gate override push button switches until the gate position is at full opening. Release push button switches and gate position will return to full close. There should be 1/16" clearance between the gate and the spread roll. If this clearance is not constant across the full width of the hopper, it indicates that wear plates may need to be adjusted or the spread roll is not straight. Contact the factory for straightening instructions.

IMPORTANT

1. Since the Chipspreader is designed to operate on new sealcoat surfaces, all dynamic braking is being done by the hydrostatic system. With abrupt control inputs it is possible to "scuff" the road surface during starting or stopping. However, with smooth application of control inputs, very precise accelerations and decelerations can be made, giving the ability to outperform a conventional clutch/brake/gear combination.

2. Friction characteristics on both new sealcoat surfaces and other surfaces vary considerably. Therefore stopping distances must be watched carefully, particularly when towing a truck, going downhill or in stopping from higher travel speeds.

3. The larger the truck or steeper the grade, the longer the stopping distance.

4. Traveling with the front hoppers loaded removes weight from the rear wheels thus reducing the braking effectiveness of the rear wheels while the additional weight increases the braking forces required. Carrying material in the rear hopper also increases the braking forces required and consequently increases the required stopping distance from a given speed. It is therefore highly recommended to travel or "road" the machine in an empty condition.

5. When operating with the truck, in some cases, such as on steep downgrades, the truck should assist in braking. The truck should always set its own brakes after stopping, regardless of whether the combination is stopped on a downgrade, upgrade or level. The braking effort must be a coordinated effort when required. It is therefore important to have a clearly understood means of communication between the Chipspreader and truck. This may be done by radio, hand signals, horns etc. Each truck driver should know who is to give signals, where to look for the signal and the meaning of each signal.

 WARNING
Stay off hopper while machine is moving. Machine movements could cause a fall resulting in injury or death.

Identification and Function of Controls

Refer to figure 1 for identification of described features.

1. Power/Ignition Switch.

Rotating from “off” to “on” supplies electric power to all systems and controls. Rotating the switch further to the right against the spring will engage the starter. When the engine runs, release the key and the switch will remain in the “on” position. Note the engine will not start with the “park/drive” switch in the drive position. It is also recommended that the control joystick be in the neutral position during startup. If started without the control joystick in neutral, the Chipspreader will not move until the joystick has been brought back to neutral.

Since all functions except power steering, and rear brakes are electrically controlled, turning the key to “off” results in a violent stop.

 WARNING
Turning ignition switch to “off” results in a violent stop.

SHUT MACHINE OFF AND WAIT FOR ALL MOVEMENT TO STOP BEFORE LEAVING OPERATOR’S SEAT OR SERVICING

FAILURE TO DO SO COULD RESULT IN UNEXPECTED MOVEMENT AND CAUSE SERIOUS INJURY OR DEATH

2. Mode Selector-Drive/Park

A two position switch selects either “Drive” or “Park” position.

In “Park” mode, the “speed/direction handle”, (9) is disabled and the parking brake is applied. The parking brake is applied when the chipspreader is stopped by returning the speed/direction handle to neutral, regardless of the position of the “Drive/Park” switch.

In the “Drive” position, the parking brake will release when the “Speed/direction handle”, (9) is moved from the neutral position resulting in forward or reverse motion of the chipspreader.

Since engaging “Park” disables “Speed/direction handle” and applies the parking brake, selecting park while the chipspreader is moving will result in a violent stop. Do not select “Park” unless the chipspreader is at a full stop.

Auxiliary computer power is routed through the Park/Drive switch/ When the engine is not running, place the switch in the Park position to avoid draining the batteries.

The “Park/Drive” switch must be in the park position after the computer has been turned on for the Chipspreader to be movable. If the computer is reset with the “Park/Drive” switch in drive, it must be moved to park first and then back to drive to resume normal operation. Similarly, the control joystick must be brought back to the neutral position after a computer restart to resume normal operation.

 WARNING
Selecting “park” while the chipspreader is moving results in a violent stop.

 CAUTION
Always place the mode selector switch in the “Park” position when the chipspreader is stopped to avoid accidental movement of the machine

3. Speed Set Toggle Switch

When in the “Drive” position, this switch provides the command signal (or set point) to the computer. This switch is used to set the desired Chipspreader speed in feet per minute. Pushing the toggle switch up will increase the speed set point, while pushing the switch down will decrease the speed set point. The computer display screen will display the set point until the control handle is moved out of neutral, and then it will display the actual speed. Once the speed is set, the Chipspreader will repeat that speed any time the control handle is pushed fully forward. The “Speed Set Toggle Switch” can be pushed to either increase or decrease the set point while the Chipspreader is moving. When this is done, the Chipspreader will smoothly transition to the new set point, and the display will display the set point rather than the actual speed. When the switch is released, the display will switch back to the actual speed.

If the engine cannot maintain the Chipspreader’s speed on a steep hill, bring the control handle rearward toward neutral to slow the Chipspreader down so that the engine can recover to high idle rpm, and when the steepness of the hill decreases, or the truck lightens up, push the control handle fully forward again to return to the set speed.

4. Aggregate Size Switch.

This switch selects the size of the aggregate to be spread. The size should be set to the size of the aggregate to be spread before setting the application rate and doing any calibrating of material.

The choices of aggregate size are: Sand, 1/4" Chips, 3/8" Chips, 3/8" Gravel, 5/8" Chips, and 1" Chips.

The amount of aggregate applied on the ground (application rate) is a function of the front hopper gate opening. The gate opening is determined by the selected aggregate (i.e. 3/8 chips) and the chipspreader speed.

The computer controls the gate opening to maintain the application rate (i.e. 20.0 lbs/yd²).

5. Application Rate Switch.

This switch sets the position to which the gates will open, by increasing or decreasing the setpoint. The set point is the application rate, in lbs/ yd², that will be delivered when the Gate/Spread Roll switch (10) is activated. Pushing the switch up will increase the set point while pushing the switch down will decrease the set point. The set point can be changed at any time whether spreading aggregate or not.

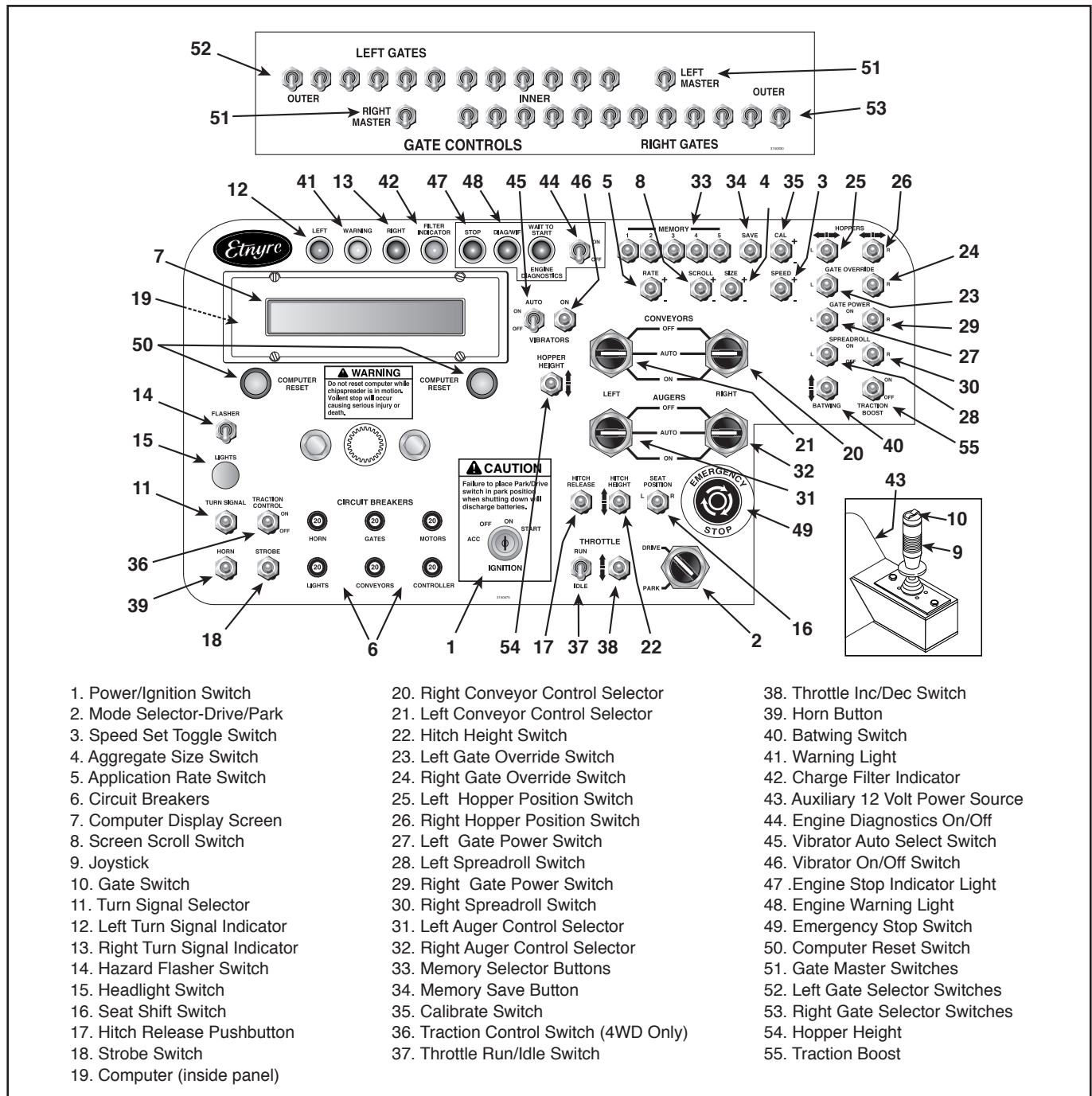

Figure 1. Control Panel Identification

6. Circuit Breakers.

These circuit breakers are powered from the accessory post on the ignition switch and lose voltage when starter is engaged.

Light circuit breaker: Supplies power to all lights except brake lights.

Conveyor circuit breaker: Supplies power to conveyor and auger switches.

Controller circuit breaker: Supplies power to the joystick, display, hitch functions, hopper functions, seat position, batwings, and gate override.

These circuit breakers are powered from the ignition post on the ignition switch and maintain voltage while starter is engaged.

Horn circuit breaker: Supplies power to the horn, input switches, and front control box.

Gate circuit breaker: Supplies power to the gate power switches, the spreadroll power switches, and the individual gates when required.

Motor circuit breaker: Supplies power to the brake lights, speed sensor, and traction control switch.

The computer is fused with an in-line, 30 amp fuse and is powered from the accessory post on the ignition switch.

7. Computer Display Screen.

OPERATOR SCREENS

20.0	3/8	400
lb/yd²	Chip	fpm

The screen shown above is displayed when power is turned on to the computer. This screen shows the application rate set point, aggregate size, and the speed set point while at a stand still. These values can all be changed depending on the application as described in earlier sections. When the chipsreader is powered down, the values currently on the screen are saved and returned the next time power is turned on.

The speed setpoint is displayed while the chipsreader is not moving. Once the chipsreader is in motion, the actual speed is displayed. The speed feedback is generated by a magnetic pickup mounted on the motor output shaft which generates pulses which the computer displays as feet per minute (FPM).

Different configurations of these three values can be saved in one of five memory presets. The memory presets store an application rate set point, an aggregate, and a speed set point in one of the memory locations. The memory pushbutton then restores the information stored in that location to the screen when activated. This

allows the operator to switch between stored combinations with the push of a button as opposed to having to scroll the individual values.

To save information in a memory, adjust the application rate set point, the aggregate size, and the speed set point to values that will be commonly used together. When the values displayed on the screen are set to the desired values, press the save pushbutton. Activating the save pushbutton will change the display to read “Select location 1, 2, 3, 4 or 5”. Select the location, or memory, the information is to be stored in by pressing the corresponding memory pushbutton (i.e. memory 1). The display will return to the main operator screen depicted above when this has been done. As a check, press the memory pushbutton the information was saved to prompting the display to read “Restoring memory 1”. The display will then show the values saved in memory 1.

Certain material conditions could require a calibration of the computer to insure the application rate set point is equal to the actual application on the ground. It is important to understand that the aggregate is being calibrated and not the memory. For example, if 3/8 chips are saved in memory 1 with an application rate setpoint of 20.0 lb/yd² and also in memory 2 with an application rate of 8 lb/yd², a calibration of 3/8 chips will update both memory locations. The memory functions serve as a means to quickly change between frequently used operating parameters.

If the set point on the display is dramatically different from the application on the ground it is possible the incorrect aggregate has been selected. Assuming this is not the case, the following procedure should be used to calibrate the aggregate to correct the application rate information stored in the computer.

MATERIAL CALIBRATION

Before calibrating a material, verify that both spread rolls are turning at 96 rpm. The aggregate to be calibrated needs to be selected on the display (i.e. 3/8 chips). Set the application rate setpoint to the desired value (i.e. 20 lb/yd²). The speed setpoint should be set around 300 FPM. Using the canvas supplied, place on a flat surface leaving plenty of room for the chipsreader to get up to speed. With the control handle in the full forward position to assure constant speed, maneuver chipsreader towards the canvas. Actuate the gate thumbswitch about 10 feet before the material will hit the canvas to insure the gate is in the correct position. Deactivate the gate thumbswitch once the canvas is covered. Weigh the material and the canvas with the scale provided. Empty the canvas and weigh it empty. Subtract the empty canvas weight from the total weight to arrive at the pounds per square yard. On a variable hopper machine, this will need to be done for the left

and right hopper. Do this a minimum of 3 times and average the values before making any changes.

Compare the measured values against the application rate setpoint on the display to determine calibration required for each hopper. As an example, assume the left hopper weighed in at 23.5 lbs and the right hopper weighed 18.0 lbs. Press the cal switch up or down to access the calibration screens. The screen will now read:

0.0	95.6%
lb/yd²	RIGHT CAL

The right hopper measured 18.0 lbs and the setpoint is 20.0 lbs, meaning the right hopper is 2 lbs light. Press and hold the cal switch up (+) until the lb/yd² reads 2.0. The RIGHT CAL value will decrease as the rate is increased, and increase as the rate is decreased. The RIGHT CAL value is a density factor that serves as a reference to keep track of the calibration. Press the save pushbutton to store the calibration for the right hopper. This process will increase the output of the right hopper by 2.0 lbs making the output equal to the application rate setpoint. The screen will reset to zero once the save pushbutton is activated.

Press the scroll switch down (-) to access the calibration screen for the left hopper which displays the following:

0.0	95.6%
lb/yd²	LEFT CAL

The left hopper weighed 23.5 lbs at the application rate setpoint of 20.0 lbs/yd². The measured weight is 3.5 lbs heavy compared to the setpoint. Press and hold the cal switch down (-) until the lb/yd² reads -3.5. The LEFT CAL value will decrease as the rate is increased, and increase as the rate is decreased. The LEFT CAL value is a density factor that serves as a reference to keep track of the calibration. Press the save pushbutton to store the calibration for the left hopper. This process will decrease the output of the left hopper by 3.5 lbs making the output equal to the application rate setpoint. The screen will reset to zero once the pushbutton is activated.

The calibration for the left and right hoppers is now complete. To exit the calibration screens, press the scroll switch up (+) two times to return to the main operators screen. The calibration screens can be exited at any time by pressing the scroll switch without changing the calibration. The calibration is changed only by pressing the save pushbutton. The calibration process may need to be repeated depending on the accuracy desired. For very accurate calibrations (± 2.0 lbs) it will be necessary to weigh at least three samples

to get an average material weight to use in the calibration process.

The calibration process will correct both hoppers to spread very close to the application rate setpoint. While chipping it may become evident that one side appears heavier or lighter than the other. This can be fine tuned using the calibration process explained above while chipping. If the left hopper appears lighter than the right, press the cal switch and scroll to the left calibration screen. Toggle the cal switch up (+) to raise the 0.0 to 1 or 2 lbs and press the save pushbutton. This will increase the output of the left hopper without effecting the right. The change will take effect as soon as the save pushbutton is activated and should be noticeable on the ground. This process can be repeated until the left and right hoppers appear the same.

The calibration process is permanent, meaning when the machine is powered down the changes will be saved for the next time the machine is put to use.

To move to the next screen, press the scroll switch down (-).

Left Conv	Right Conv
0%	0%

This screen shows how fast the conveyors are moving. The speed of the conveyors can be varied independently to provide a uniform distribution of material to the front hopper. With the percentage set to 99% the conveyor will run at its highest speed. With the percentage set to 10% the conveyor will run at its slowest speed. To change the speed of the conveyors press the CAL switch up or down. The screen will now show the set percentage of the left conveyor.

Left Conv
85%

Pressing the cal switch up (+) will increase the left conveyor speed by 5%. Pressing the cal switch down (-) will decrease the left conveyor speed by 5%. Pressing the scroll switch down (-) will show the screen for changing the right conveyor speed.

Right Conv
85%

Pressing the cal switch up (+) will increase the right conveyor speed by 5%. Pressing the cal switch down (-) will decrease the right conveyor speed by 5%. Pressing the scroll switch up (+) will show the screen for changing the left conveyor speed. Pressing the scroll switch up (+) again will show the actual speed of both conveyors. The conveyor speed percentage can be changed at any time whether or not the conveyors are moving.

Adjusting the speed of the conveyors is particularly useful in doing shoulder work or in operations requiring less than full hopper width. It is also useful in trying to smooth out delivery of material to match the rate being spread. When properly adjusted, the conveyors should run approximately 80% of the time with the hopper at maximum width and the Chipsreader traveling at maximum speed for the particular job.

To move to the next screen, press the scroll switch down (-).

Left Auger Right Auger
0% 0%

This screen shows how fast the augers are moving. The speed of the augers can be varied independently to provide a uniform distribution of material in the front hopper. With the percentage set to 99% the auger will run at its highest speed. With the percentage set to 10% the auger will run at its slowest speed. To change the speed of the augers press the CAL switch up or down. The screen will now show the set percentage of the left auger.

Left Auger
85%

Pressing the cal switch up (+) will increase the left conveyor speed by 5%. Pressing the cal switch down (-) will decrease the left auger speed by 5%. Pressing the scroll switch down (-) will show the screen for changing the right auger speed.

Right Auger
85%

Pressing the cal switch up (+) will increase the right auger speed by 5%. Pressing the cal switch down (-) will decrease the right auger speed by 5%. Pressing the scroll switch up (+) will show the screen for changing the left auger speed. Pressing the scroll switch up (+) again will show the actual speed of both augers. The auger speed percentage can be changed at any time whether or not the augers are moving.

To move to the next screen, press the scroll switch down (-).

100°F 60 PSI 15%
WATER OIL FUEL

This screen shows the engine coolant temperature on the left, the engine oil pressure in the center, and the fuel remaining in the fuel tank on the right. To move to the next screen, press the scroll switch down (-).

100°F 2200 RPM 13.8 V
HYD OIL ENGINE BATTERY

This screen shows the hydraulic oil temperature on the left, the engine rpm in the center, and the system

voltage on the right side. The right side will display battery voltage when the ignition is on but the engine is not running. The voltage will increase to 13.5 to 15.0 volts as the output of the alternator supplies voltage to the system. To move to the next screen, press the scroll switch down (-).

120.8 7550 FT
ENGINE CHIPPED

This screen shows the hours on the machine on the left side, and the feet chipped on the right side. When the ignition key is turned on but the engine is not running, the hours will not accumulate since the hourmeter is started and stopped by an oil pressure switch. If the engine is shut down after running less than 6 minutes, the hourmeter will not increase, as it counts up in 6 minute increments. Once the engine is started, the hours will start to accumulate. The feet chipped will accumulate as long as the gate thumbswitch is activated. Distance will not accumulate when traveling and not chipping. To reset to 0, press the cal switch up or down. You must push the scroll switch up to return to each previous screen, eventually returning to the top screen.

A series of alarm functions are built into the computer. If an item sensed by the computer reaches its programmed alarm condition, the appropriate item will appear and flash on the screen, regardless of what screen is currently displayed. In addition, an output is sent to the beeper and also to the warning light mounted in the upper part of the control box. For instance, the normal use will be to have the first screen displayed (FPM & LBS/SQ. YD) - this will automatically be displayed on starting the engine. If the fuel level gets down to the alarm level (approximately 10% or 7 gallons), the words "low fuel" will flash, the beeper will sound and the warning light below the steering wheel will come on. The same is true for any of the items monitored which have alarm points. The alarm points are as follows:

- high water temperature 240 F
- low fuel 10%-7 Gal.
- high hydraulic oil temp. 180 F.
- low voltage 12 volts
- high voltage 15 volts

8. Screen Scroll Switch

This switch is used to scroll the screen from the first to the fourth screen. You scroll down one screen each time you push the switch down. Upon reaching the last screen, you must push the scroll switch up to return through the screens to the first screen.

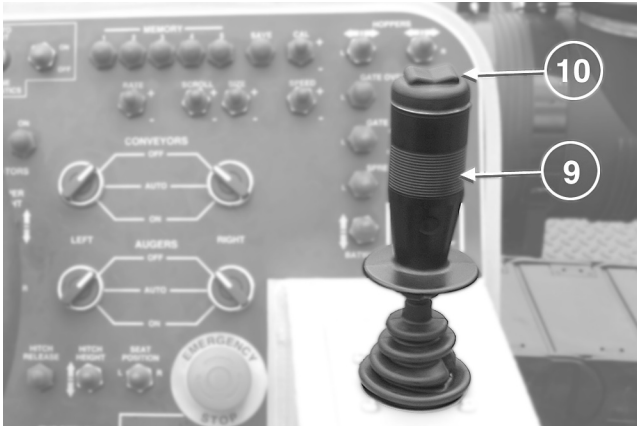

Figure 2. Speed/Direction Control Handle

9. Control Handle 10. Gate/Spread Roll Switch

9. Speed/Direction Control Handle (Figure 2)

The control handle controls both direction (forward, neutral, reverse) and rate of speed.

Full reverse movement will give 100% of the preset speed in reverse, up to 1300 fpm. In order to back up faster, you must increase the speed setting. After backing up, you must reselect the appropriate memory button to reset the speed to your chipping speed. Full forward movement will give 100% of the selected speed set point. Speed can be slowed down at any time by pulling the handle back towards neutral and resumed by pushing the handle fully forward at any time. The control handle controls the rate of acceleration and deceleration. If the handle is moved quickly, the Chipspreader will respond quickly. If the control handle is moved slowly, the Chipspreader will respond slowly.

The control handle also incorporates a neutral safety switch to hold the parking brake off when the control handle is out of the neutral position. The handle has a detent in the neutral position and an adjustable friction drag for holding at any desired position other than neutral.

PARKING BRAKE MEETS SAE J1472

PARKING BRAKE MAY NOT HOLD ON GRADES STEEPER THAN 15%

Decelerating is always accomplished by moving the handle toward neutral. Upon reaching the neutral position of the handle, the parking brake will be automatically applied, after the speed sensor reads “0” speed.

The control handle will operate as follows: moving the handle rearward out of the neutral position approximately 3 degrees will activate the backup alarm and release the brakes. Moving the handle further rearward will increase the reverse speed proportionate to the handle movement until full set speed is achieved

with the handle in the full reverse position. Moving the handle forward out of the neutral position approximately 3 degrees will release the brakes and begin to increase the forward speed until at the full forward position of the handle the Chipspreader will be at 100% of the set point speed and the computer will maintain the set speed. If the set speed is 200 fpm, the handle must be moved fully forward to obtain 200 fpm. If the set speed is 500 fpm, the handle must be fully forward to reach 500 fpm. The rate of acceleration, to the set speed, is controlled by how fast the handle is moved from neutral to the full forward position. Adjustments to the set point speed are made using the “Speed” toggle switch. A change in the speed setpoint may be made at any time using the “Speed” toggle switch. The speed may be decreased at any time by moving the handle rearward toward neutral without changing the set point and then be brought back up to the set point by moving the handle fully forward again. The Aggregate Application rate is automatically maintained when either of these methods is used to adjust the travel speed.

Stopping is always accomplished by returning the handle to neutral.

10. Gate/Spread Roll Switch (Figure 2)

This rocker switch (10) activates the spread roll and also the command circuit for the gates. The gate opening is set by the rate switch (5) to the desired opening. The gates are then opened or closed with the gate/spread roll switch. Depressing the left side of the switch closes the gates, while depressing the right side opens the gates. When used this way the gates will go from closed to the required opening for the speed and application rate or from the required opening to closed.

The gate opening will vary, depending on the speed of the Chipspreader, to maintain the set application rate. The gate switch may be turned on at any time. If the speed is too slow for the size aggregate the desired application rate of material will not flow out of the hopper, but the gates will be open to an opening dependent on the speed, and as the speed increases, the gates will continue to open further to maintain the selected Application Rate. If the speed is increased or decreased using either the “Speed Toggle Switch” or the control handle, the gates will open or close as necessary to maintain the set application rate. When the Chipspreader has come to a halt, depress the left side of the rocker switch to close the gates. The gates will close automatically when the Chipspreader’s speed is less than 30 fpm even if the switch is left on and will remain closed in neutral without being turned off, however, if they were not turned off, they will immediately begin to open whenever the forward or reverse speed exceeds 30 fpm.

11, 12, 13. Turn Signal Selector and Indicators. (Figure 4)

Push the switch to the right to signal a right turn, and to the left to signal a left turn.

 CAUTION
Turn signals are not self canceling

14. Hazard Flasher Switch (Figure 4)

Push up for “on” and push down for “off”.

15. Headlight Switch. (Figure 4)

Pull out for “on” and push in for “off”.

 WARNING
Check local regulations and codes to determine the lighting and marking requirements for your usage.

16. Seat Shift Switch. (Figure 4) (Optional)

Hold the switch right or left to move the seat to the desired position. The moving seat is meant to be an operator convenience during chipping.

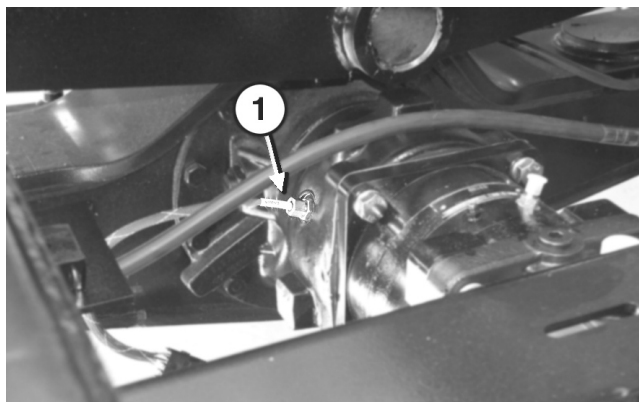

Figure 3. Ground Speed Pickup

- 1. Magnetic Pickup

17. Hitch Release Pushbutton. (Figure 4)

Push the hitch release pushbutton to disengage the Chipspreader from the supply truck. There must be some “slack” in the hitch (between the Chipspreader and supply truck) in order for the latch to release. While pushing the hitch release pushbutton, one should momentarily pull the control handle rearward slightly to slow the Chipspreader. This will cause the required “slack”. The control stick should then be pushed forward again, while still depressing the hitch release pushbutton. Once the truck has separated from

the Chipspreader, the hitch release pushbutton can be released. A second hitch release pushbutton is provided at the front operator’s controls.

It is possible to stop with no “slack” in the hitch (between the Chipspreader and supply truck). If this happens, the Chipspreader must be backed up slightly to create the necessary “slack” and then driven forward while pushing the hitch release pushbutton.

In order to hook up to a supply truck, momentarily depress the hitch release pushbutton to open the hitch if it is not already open, and back into the truck. The hitch automatically closes and locks when it contacts the back of the truck.

18. Strobe Switch. (Optional)

Push the switch up to turn on the optional strobe or beacon and down to turn it off.

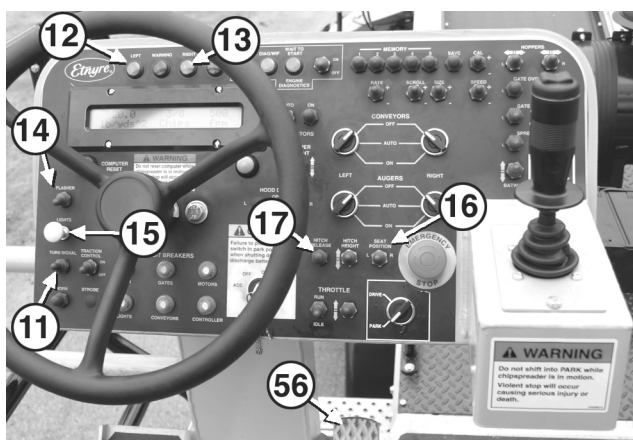

Figure 4. Control Panel

- | | |
|------------------------------|----------------------------------|
| 11. Turn Signal Selector | 14. Hazard Flasher Switch |
| 12. Lt Turn Signal Ind | 15. Headlight Switch |
| 13. Rt Turn Signal Ind | 16. Seat Shift Switch (optional) |
| 17. Hitch Release Pushbutton | 56. Brake Pedal |

19. Application Rate Computer. (inside control panel)

The speed pickup (Figure 3) feeds a pulse speed signal to the computer. The gate position feedback transducer feeds a gate position signal to the computer. The computer compares the speed feedback signal to the set point and sends the appropriate signal to the pump to maintain the set speed. The computer also calculates the required gate opening for the set application rate and opens and closes the gates to maintain the application rate.

Normal spreading would be done as follows:

- a) Place the control handle in neutral.
- b) Set the desired speed using the Speed Toggle Switch (3).

c) Turn the gate/spread roll switch (10) “off”.

d) Set the desired application rate using the Rate Switch (5), or select the appropriate memory by pushing the appropriate memory button.

e) Push the speed/direction handle (9) forward smoothly to the full forward position to accelerate to the speed set point.

f) Upon reaching the starting line of spreading, depress the right side of the gate/spread roll switch (10) fully to turn the gates “on”.

g) Upon reaching the ending line, center or depress the left side of the gate/spread roll switch fully (10) to shut the gates “off”.

h) Return the control handle to neutral.

Speed changes may be made while moving by using the Speed Toggle Switch to set a new speed. The Chipspreader will change speed to the new speed. The application rate will remain the same as long as the Chipspreader is within the limits of gate opening for the particular aggregate selected.

If a speed is reached which requires a gate opening greater than that available for the aggregate selected, or than the hopper has available, the gates will remain open but the Chipspreader will not be able to maintain the set application rate. Increase speed to resume set application rate.

20. Right Conveyor Selector

In the bottom position, the conveyor is turned “On”.

In the middle position, power is supplied to the auto switch mounted on top of the conveyor hood. (See fig. 8) When this switch senses material, the conveyor will shut off and conversely when no material is sensed it will start the conveyor attempting to fill the hopper.

In the upper position, the conveyor is turned “Off”

At any point, regardless of the position of the Right Conveyor Selector, the front operator can momentarily turn on the right conveyor using the pushbutton switch in the front control box.

21. Left Conveyor Selector.

Same operation as above except for left conveyor and left conveyor auto switch.

Since both conveyors are independently controlled, it is possible to run one conveyor in one mode of control while running the other conveyor in a totally different mode if so desired.

22. Hitch Height Switch.

Push up to raise the hitch, push down to lower the hitch. When the switch is released, the cylinder will hold

the hitch at a given height, about which it is free to float up and down on a spring to provide vertical articulation between the Chipspreader the truck.

23. Left Gate Override Switch

Depress to momentarily fully open the left hopper gate to clear a jam. Upon releasing the pushbutton, the gate will return to its original set point.

24. Right Gate Override Switch

Depress to momentarily fully open the right hopper gate to clear a jam. Upon releasing the pushbutton, the gate will return to its original set point.

25. Left Hopper Position Switch

Push left to extend the left hopper and push right to retract the left hopper.

26. Right Hopper Position Switch

Push right to extend the right hopper and push left to retract the right hopper.

27. Left Gate Power Switch

This switch connects or disconnects the left hopper’s gate to the “gate/spread roll” switch (Ref 10). When connected, the hopper is then turned “on” or “off” using the “gate/spread roll” switch.

28. Left Spread Roll Switch

This switch connects or disconnects the left hopper’s spread roll to the “gate/spread roll” switch (Ref 10). When connected, the spread roll is then turned “on” or “off” using the “gate/spread roll” switch.

29. Right Gate Power Switch

This switch connects or disconnects the right hopper’s gate to the “gate/spread roll” switch (Ref 10). When connected, the hopper is then turned “on” or “off” using the “gate/spread roll” switch.

30. Right Spread Roll Switch

This switch connects or disconnects the right hopper’s spread roll to the “gate/spread roll” switch (Ref 10). When connected, the spread roll is then turned “on” or “off” using the “gate/spread roll” switch.

31. Left Auger Selector

In the bottom position, the left auger is turned “On”.

In the middle position, power is supplied to the auto switch located at the outboard end of the left hopper. When this switch senses material, the auger will shut off and conversely when no material is sensed, it will

start the auger attempting to fill the outer end of the hopper.

In the upper position, the auger is turned “Off”.

32. Right Auger Selector

In the bottom position, the right auger is turned “On”.

In the middle position, power is supplied to the auto switch located at the outboard end of the right hopper . When this switch senses material, the auger will shut off and conversely when no material is sensed, it will start the auger attempting to fill the outer end of the hopper.

In the upper position, the auger is turned “Off”.

33. Memory Selector Buttons

These switches select which of the 5 preset aggregate combinations of speed, application rate, size and material is to be spread.

34. Memory Save Button

This button is used to save the preset combination once it has been set to the desired parameters. See the section on page 10 titled "Material Calibration" and saving in a preset location.

35. Calibrate Switch

This switch is used to calibrate the material before use. See the section on Material Calibration and saving in a preset location.

36. Traction Control Switch

This switch transfers torque to the front axle. The joystick must be in neutral to engage this switch. If a rear wheel spins, position the joystick in neutral and move the traction control switch to the on position. Move the joystick out of neutral and drive the chipspreader into an area with better traction. The chipspreader speed is limited to 200 fpm while the switch is engaged. When this switch is moved to the off position, the machine will resume set point speed.

37. Throttle Run/Idle Switch

The engine should be started with the switch in the idle position. The engine will run at low idle when the switch is in this position. When the switch is in the run position, the engine will run at high idle. The hydrostatic system is designed to run at high idle, therefore the switch should be in this position to perform any work.

38. Throttle Increase/Decrease Switch

Press the switch up to increase the engine RPM and down to decrease the engine RPM. The minimum recommended engine speed is 900 RPM.

39. Horn

This button is used to operate the Chipspreader’s horn for signalling the truck or warning of danger.

40. Batwing Switch

This switch is used to operate the batwing hopper. Push up to raise the batwings, and down to lower.

41. Warning Light

This light will be activated whenever one of the monitored functions reaches its alarm point. As in high oil temperature, high engine coolant temperature, low engine oil pressure, low voltage, and low fuel. The function which has reached its alarm point will be described in the computer’s digital display.

42. Filter Indicator

This light indicates that the charge pressure filter is clogged when lit.

43. Auxiliary 12 Volt Power

A “Cigarette Lighter” style 12 volt power supply. This supply is on when the ignition switch is in the on position or the accessory position.

44. Engine Diagnostics On/Off Switch

With the ignition switch in the on position (engine not running) position the diagnostic switch in the on position to access the engine fault codes. The stop light (Ref 47) will flash a series of times corresponding to a particular fault code. The warning light (Ref 48) will light when the code is finished. If more than one fault code is present, use the throttle increase/decrease switch to scroll through the active fault codes. The throttle switch functions in this manner only when the engine diagnostics switch is in the on position, otherwise it functions as the throttle switch.

45. Vibrator Auto Select Switch (Optional)

This switch places the vibrators, if so equipped, in the auto mode. The vibrators will cycle on with activation of the gate/spreadroll switch for the set time and then shutoff. The on time is adjustable from 1 to 10 seconds on the timer inside the control panel.

46. Vibrator Manual On/Off Switch (Optional)

This switch will turn on the vibrators when held in the up position and automatically returns to the off position when released.

47. Engine Diagnostics Stop Light

When the stop light is lit, shut down the engine. Access the fault code and call your Cummins dealer.

48. Engine Diagnostics Warning Light

The warning light indicates something is wrong with the engine and should be looked into soon.

49. Emergency Stop Switch

The emergency stop switch will bring the chpspreader to a controlled stop when activated, regardless of the joystick position. The switch stops the engine while maintaining electrical power, insuring a predictable stop. To restart the engine, the switch must be reset by turning the knob clockwise. the foot pedal service brake is active with the emergency stop switch and can be used to bring the chpspreader to a quicker stop.

50. Computer Reset Switch

WARNING

Do not reset computer while chpspreader is in motion. Violent stop will occur which could cause a fall resulting in injury or death.

When activated simultaneously, the computer reset switches will reset the computer. Activating a single switch will have no effect on the computer. In the event of an alarm that limits the speed of the machine, the computer can be reset without turning off the engine. Bring the machine to a stop before pressing the Computer Reset buttons. A violent stop will occur if the buttons are pressed while the machine is in motion. The park/drive switch must be placed in the park position, and the joystick must be in the neutral position while resetting the computer. The chpspreader will not respond to the joystick until both the park/drive switch has been placed in the park position and the joystick has been placed in the neutral position.

51. Individual Gates Master Switch

This switch connects the selected individual gates to the Thumb Switch on the top of the control stick so that the selected gates will open when the Thumb Switch is turned on. A more detailed description of how the gate operates is located in the section on the Individual Gates.

52. Left Hopper Gate Selector Switches

These switches select which gates on the left hopper will be opened when the Thumb Switch is turned on. Once the hopper is spreading, these switches are used to control individual gates on the left hopper, turning them on or off as the spread requires. A more detailed description of how the gate operates is located in the section on the Individual Gates.

53. Right Hopper Gate Selector Switches

These switches select which gates on the right hopper will be opened when the Thumb Switch is turned on. Once the hopper is spreading, these switches are used to control individual gates on the right hopper, turning them on or off as the spread requires. A more detailed description of how the gate operates is located in the section on the Individual Gates.

54. Hopper Raise/Lower Switch

This switch is used to change the height of the hopper. Push up to raise the hopper and down to lower hopper.

55. Traction Boost Switch (Optional)

This switch activates a cylinder which pushes up on the hitch. When attached to a truck this function increases traction on the chpspreader's rear tires. This switch should only be activated while attached to a truck and there will be no increase in traction while disconnected from a truck. The hitch release switch will not function while traction boost switch is active.

CAUTION

Traction Boost may reduce braking efficiency of truck.

56. Brake Pedal (Figure 4)

The brake pedal can be used to assist the hydrostatic braking. For instance, the parking brake is applied when the computer sees the chpspreader is stopped. On a grade, the chpspreader may roll back, since it did not come to a complete stop and apply the parking brake. The foot brake will hold the chpspreader on the grade until the parking brake is set.

When the chpspreader is in motion and the brake pedal is applied, a pressure switch in the brake line sends a 12 volt signal to the computer, which destrokes the pump. The chpspreader will decelerate as long as the brake pedal is applied until it comes to a stop, regardless of the joystick position. To resume operation, the joystick must be returned to center. If the brake pedal is released during deceleration, the speed at that instant will become the new speed set point. For example, if the chpspreader is traveling at 1000 FPM and the brake pedal is applied, the chpspreader will begin to decelerate. If the brake pedal is then released at 500 FPM, this will be the new speed set point. When the joystick is returned to center, the speed set point will return back to the original 1000 FPM.

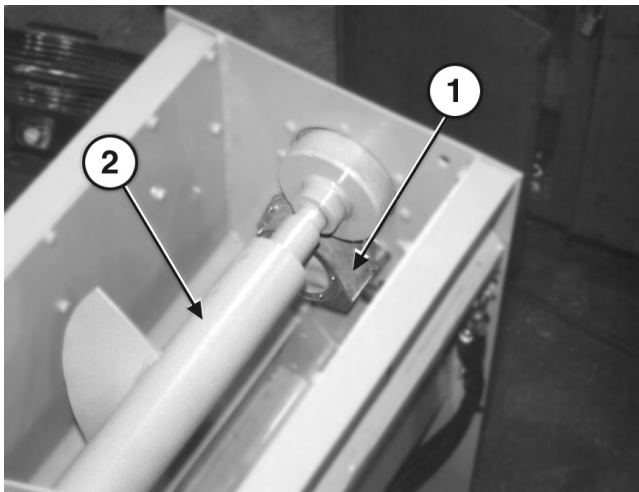

Figure 6. Auger Auto On/Off Switch

- 1. Switch
- 2. Auger

Items 57 thru 65 are located in the front operator's control box (figure 7)

57. Left Hopper Switch (Figure 7)

Push left to extend the left hopper and push right to retract the left hopper.

58. Right Hopper Switch (Figure 7)

Push right to extend the right hopper and push left to retract the right hopper.

59. Left Conveyor Pushbutton (Figure 7)

Pressing switch will turn left conveyor on independent of *Left Conveyor Selector*. Releasing switch will transfer conveyor switch control back to Left Conveyor Selector.

60. Right Conveyor Pushbutton (Figure 7)

Pressing switch will turn right conveyor on independent of *Right Conveyor Selector*. Releasing switch will transfer conveyor switch control back to Right Conveyor Selector.

61. Hitch Release Pushbutton (Figure 7)

Push the hitch release pushbutton to disengage the supply truck from the Chipspreader. (See item 17 "Hitch Release Pushbutton, operator's control panel")

62. Left Auger Pushbutton (Figure 7)

Pressing switch will turn left auger on independent of *Left Auger Selector*. Releasing switch will turn left auger off depending on *Left Auger Selector* position.

63. Right Auger Pushbutton (Figure 7)

Pressing switch will turn right auger on independent of *Right Auger Selector*. Releasing switch will turn right auger off depending on *Right Auger Selector* position.

⚠ WARNING

Auger may start automatically at any time! Do not attempt to clear any jam with the engine running.

64. Left Gate Override Switch (Figure 7)

Depress to momentarily fully open the left hopper gate to clear a jam. Upon releasing the pushbutton, the gate will return to its original set point.

65. Right Gate Override Switch (Figure 7)

Depress to momentarily fully open the right hopper gate to clear a jam. Upon releasing the pushbutton, the gate will return to its original set point..

⚠ WARNING

Unsafe operation of equipment may cause injury. Read, understand and follow the manuals when operating or performing maintenance.

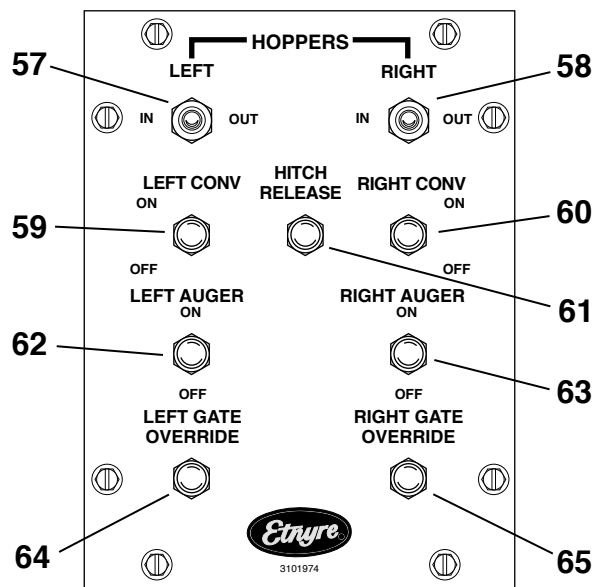

Figure 7. Front Operator's Control Panel

- 57. Lt Hopper Switch
- 58. Rt Hopper Switch
- 59. Left Conveyor Switch
- 60. Right Conv Switch
- 61. Hitch Release Pushbutton
- 62. Lt Auger Switch
- 63. Rt Auger Switch
- 64. Left Gate Override
- 65. Right Gate Override

OPERATION

WARNING

Unsafe operation of equipment may cause injury. Read, understand and follow the manuals when operating or performing maintenance.

Never place hands between the spread roll or gate and rear of hopper. The gate could move at any time and cause severe injury.

Do not travel with the seat unlatched. Seat movement could occur causing disorientation and possible loss of control.

Remain clear of all moving parts.

CAUTION

Before operating the Chipspreader, make an inspection of the machine to be sure that the machine is in a safe condition to operate.

WARNING

Always use steps, platforms and handrails provided.

Always have shields, covers and guards in place when operating.

Make certain everyone is clear of machine before starting or operating the machine.

Since all functions except power steering and brakes are electrically controlled, turning the ignition key to "off" results in a violent stop.

Keep loose clothing away from conveyor area when operating the conveyors.

CAUTION

Always install locking control box cover and chock wheels when leaving machine unattended as protection against vandalism and accidental movement.

IMPORTANT

Do not tow the Chipspreader before reading the towing instructions contained in this manual. Improper towing may damage the hydraulic motors.

WARNING

Unsafe operation of equipment may cause injury. Read, understand and follow the manuals when operating or performing maintenance.

Never put hands in between gate and spread roll or gate and rear of hopper. The gate could move at any time and cause severe injury.

Remain clear of all moving parts.

Should a piece of foreign material become lodged in the gates, push the gate override pushbutton (Ref. 23 or 24, Fig. 1) to open the appropriate gate above the set point to allow the piece to pass. Releasing the override will return the gates to the previously set position.

Adjust Chipspreader hitch height as necessary to accommodate different individual trucks.

Operate the conveyor belt switches so as to maintain an even distribution of aggregate in the front hopper.

The machine is equipped with conveyor belt speed controls. The rear conveyor gates should be set to deliver as much material as possible into the conveyor without spillage and then the conveyor speed should be adjusted to deliver slightly more aggregate to the front hopper than the amount being spread. When properly adjusted, the conveyors should run approximately 80% of the time with the hopper at maximum width and the Chipspreader traveling at maximum speed for the particular job.

Automatic Conveyor Control (Figure 1)

In the middle position, power is supplied to the auto switch mounted on top of the conveyor hood. When this switch senses material, the conveyor will shut “off” and conversely when it no longer senses material it will start the conveyor attempting to fill the hopper. (Fig. 8)

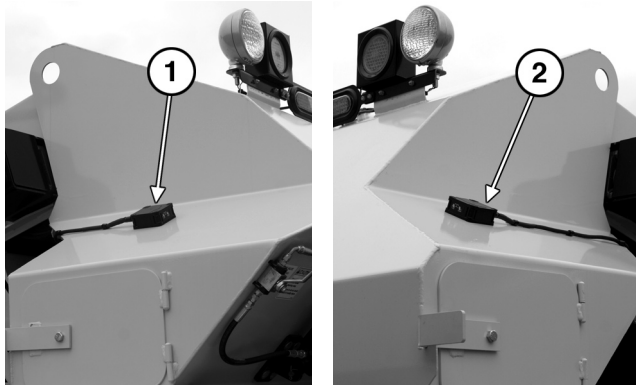

Figure 8. Conveyor Diaphragm Switches

1. Right Diaphragm Switch 2. Left Diaphragm Switch

Ultrasonic Sensors

The switching point of the ultrasonic switches can be changed to optimize flow of rock in hopper and hood. To change the switching point distance:

- 1) Turn key to the ON position and corresponding selector switch to AUTO position.
- 2) Hold A1 button until red light flashes.
- 3) Place object desired distance from switch.
- 4) Press A1 button to save.
- 5) Repeat steps 2-4 for A2 button.

CAUTION
Setting switching point to close or changing mode from desired setting may cause automatic switches to function improperly.

CAUTION
Keep loose clothing away from conveyor area when operating conveyors.

Backup Alarm

The electric backup alarm is automatically actuated when the speed/direction control handle (Fig. 2) is pulled to the rear of neutral.

WARNING
Unsafe operation of equipment may cause injury. Read, understand and follow manuals when operating or performing maintenance.

Hydraulic Powered Seat Assembly

A hydraulically powered seat positioner is operated by a spring centered toggle switch (Fig 4). The seat may be positioned wherever it is desired for operation.

Individual Gates (Figure 10)

These gates are turned on or off by air cylinders. The air cylinders either keep the gate closed, or when turned on, they open the gate up against the hydraulically positioned buss bar. The computer controls the position of buss bar according to the gate opening required. The buss bar is turned on/off by using the gate/spread roll thumb switch. For opening of all of the gates, the left and right gate power switches should be turned on and the left and right spread roll switches should be turned on. For normal operation, the Gate Master switch is turned on, and the switches for the individual gates are all turned on. When operated in this manner, the entire left and right hoppers will open across their full width. If the hoppers are fully extended, turning off individual switches on the outboard end will turn off 1 foot increments

The normal operation would be to turn on the Master gate switch and also all of the individual switches. The gates would then be turned on or off from the thumb switch on the control handle. If it is desired to turn the gates off instantly in some operations, the Gate Master switch can be turned off before the thumb switch, and then the thumb switch turned off.

Be sure to turn the Gate Master Switch back on again before opening the thumb switch or no gates will open with the buss bar.

If it is desired to spread a couple of feet at the end of a hopper for either shoulder work or patching, it is recommended that the spread roll for the hopper be turned off to avoid unnecessary wear on the portion of the spread roll that is turning against the closed gates. If the spread roll is turned off, the application rate will be less than with the spread roll on, so it will be necessary to increase the application rate to get the same amount of material.

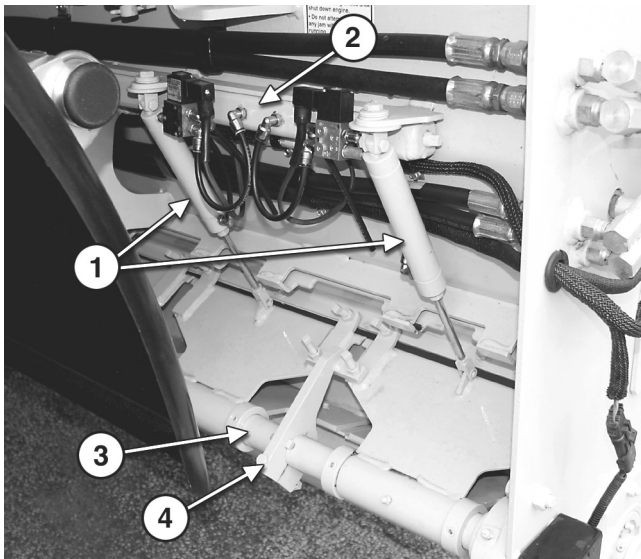

Figure 10. Individual Gates

- | | |
|------------------|-------------|
| 1. Air Cylinder | 3. Buss Bar |
| 2. Hydr Cylinder | 4. Buss Arm |

Towing Instructions

Install a chain or strap around the front hydrostatic motor and parking brake assembly and secure the assembly to the front engine crossmember. Remove the four 16mm bolts that secure the parking brake to the front axle and pull the parking brake and motor assembly away from the front axle to disengage the spline. On a 4WD machine secure the rear motor to the frame crossmember and remove the motor in the same manner. The chipspreader should be towed to an area where it can be loaded onto a trailer. It is not recommended to tow the chipspreader for long distances. When the chipspreader is placed back in service, verify that the axle differential housings are filled with gear lube to the full level.

APPENDIX A

MAINTENANCE ADJUSTMENTS

WARNING

When two people are required to perform adjustments or maintenance operations or two people are simultaneously performing different operations, the work must be coordinated between the two people to avoid possible injuries.

WARNING

When two people are performing maintenance adjustments, do not start engine without assuring that the other person is clear of moving parts and out from under the machine. Be sure that the mode selector is in park and the control stick is in neutral before attempting to start engine.

MAINTENANCE

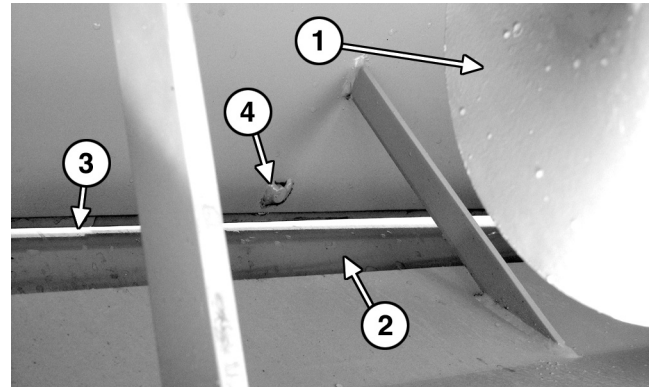

Figure 11. Spread Roll Wear Plate

(View from top of Hopper Looking Down)

- 1. Auger
- 2. Spread Roll
- 3. Spread Roll Wear Plate
- 4. Hold Down Bolts

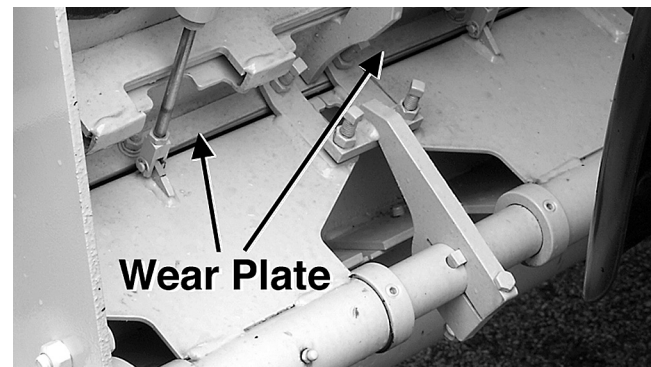

Figure 12. Hopper Gate Wear Plate

WARNING

Conveyor must be running during this procedure. To avoid personal injury, be sure to remain clear of moving belt.

Hopper Spread Roll Wear Plate Adjustment (Figure 11)

Turn the spread rolls and conveyors “off”.

1. Loosen all spread roll wear plate hold down bolts and adjust the wear plate until a nominal 1/16" clearance exists between the wear plate and the spread roll for the entire hopper width.

2. Re tighten all the hold down bolts.

3. When one side of a plate has worn excessively it is possible to turn the plate over and use the opposite side.

Hopper Gate Wear Plate Adjustment (Fig. 12)

Turn spread roll and conveyors “off”.

1. Loosen wear plate hold down bolts and extend the plate 1/32" past the gate edge along the entire gate width.

2. Tighten hold down bolts.

3. As plate wear occurs, additional adjustment will be necessary.

4. When one side of a plate has been worn away it is possible to turn the plate over and use the opposite side.

Conveyor Belt Adjustment

1. If the conveyor belt tends to move towards one side of the conveyor, tighten tail pulley adjustment on that side until the belt is running in the center.

2. Should it be impossible to obtain centered belt operation by adjusting the tail pulley (Fig. 13) it will then be necessary to adjust the head pulley as outlined below. (Fig. 14)

For the right hand conveyor:

a) Loosen the four bolts holding the right hand side head pulley bearing.

- b) Loosen adjusting bolt jam nuts.
- c) Start conveyor at this time.
- d) If belt runs to the right hand side of the conveyor, tighten the adjusting screws until the belt is centered on the head pulley.
- e) If belt runs to the left hand side of the conveyor, loosen the adjusting screws until the belt is centered on the head pulley.
- f) Re tighten adjusting screw jam nuts.
- g) Stop the conveyor belt.
- h) Tighten head pulley bearing bolts.

WARNING
Remain clear of all moving parts.

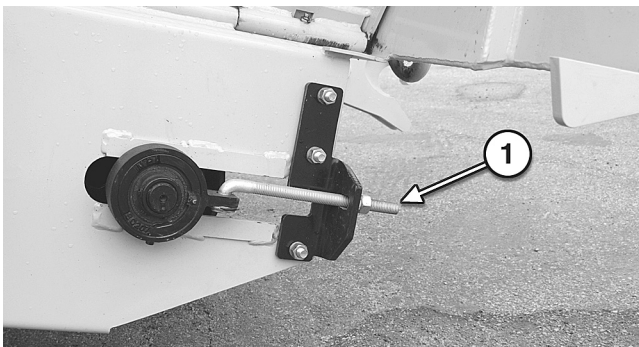

Figure 13. Conveyor Tail Pulley

1. Conveyor Belt Tail Pulley Adjustment Bolt (4 Places)

For left hand conveyor:

- a) Loosen the four bolts holding the left hand side head pulley bearing.
- b) Loosen the adjusting bolt jam nuts.
- c) Start conveyor at this time.

WARNING
Remain clear of all moving parts.

- d) If belt runs to the right side of the conveyor, loosen the adjusting screws until the belt is centered on the head pulley.
- e) If belt runs to the left side of the conveyor, tighten the adjusting screws until the belt is centered on the head pulley.
- f) Re tighten adjusting screw jam nuts.
- g) Stop the conveyor belt.
- h) Tighten head pulley bearing bolts.

NOTE: Only a small amount of head pulley adjustment should be necessary to center conveyor belts.

3. Conveyor belts should be sufficiently tight to prevent head pulley slippage when the belts are loaded and operating at full governed speed. It should be noted, however, that excessive belt tightness will result in shortened belt and pulley bearing life. It may be necessary to tighten the belts several times during the first few weeks of operation until most of the initial belt stretch has been removed. When doing so it is necessary to tighten each side equally to keep the belt running centered.

WARNING
The fuel tank is part of the crosswalk. Do not drill or weld in this area.

CAUTION
To avoid potential damage to electrical components, disconnect batteries before welding

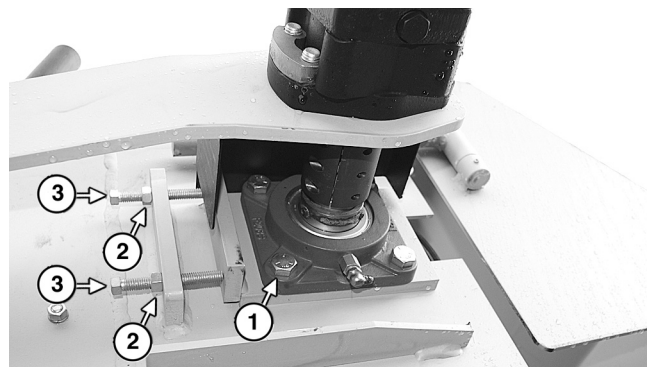

Figure 14. Conveyor Head Pulley Adjustment

(View from below, looking up)

- 1. Bearing Bolts
- 2. Jam Nut
- 3. Adjusting Screw

IMPORTANT
Do not tow the chipspreader before reading the towing instructions contained in this manual. Improper towing may damage the hydraulic motors and brakes.

APPENDIX B

COMPUTER SETUP

Computer Set Up

The computer must be set up and the various sensors calibrated for the particular Chipspreader that the computer is installed in. This is normally done at the factory, and the settings are retained in the computer's non volatile memory. Normally an entire set up does not have to be done in the field, but if a joystick or a gate transducer is replaced, that particular item would have to be re- calibrated. In the case of a gate transducer, it should be mechanically set using the procedure described under "Hopper Gate Transducer Adjustment" before re calibrating the computer. In order to do that, you must enter the set up screens and follow through the various screen as described below. If an item is already properly set, you can just scroll by it to the next item, until you get to the one that needs to be re-calibrated. If any one item is changed, you must save it using the procedure described at the end of the various screens.

Set Up Screens

The following screens are entered by holding the cal switch either up or down while turning the ignition key on.

IMPORTANT: The setup of the computer should be performed with the ignition key on, but the engine not running, except for calibrating the gates and the speed.

 CAUTION
Always place the mode selector switch in the "park" position when the chipspreader is stopped to avoid accidental movement of the machine.

These screens are used to configure the computer to the particular Chipspreader and to calibrate the speed pickup, control stick, gates, and application rate. The first screen will appear when the ignition key is released from the start position.

SETUP: FIRMWARE

Version 1.XX

This screen shows the version of firmware which is loaded in the machine. (version 1.01 for example)

Push the "scroll" switch down to move to the next screen.

SETUP: WORK MODE

This screen is used to set the machine in ship mode or work mode. In ship mode the speed setpoint is fixed at 300 FPM. Work mode allows the operator to adjust the speed setpoint in the main operator screen. Use the "cal" switch to toggle between work and ship mode. Push the "scroll" button down to move to the next screen.

SETUP: ENGINE ELECTRONIC

This screen shows how the engine communicates with the computer. With an electronic engine the computer reads the data from the engine ECU. With a mechanical engine the computer reads engine data from external sensors attached to the engine. Use the "cal" switch to toggle between electronic and mechanical engine. Push the "scroll" switch down to move to the next screen.

SETUP: DRIVE 4 WHEEL

This screen is used to set the type of drive in the machine. Either 2 wheel or 4 wheel drive. Use the "cal" switch to toggle between 2 and 4 wheel drive. Push the "scroll" switch down to move to the next screen.

SETUP: MOTOR SIZE 160 CC

This screen is used to set the motor displacement. Use the "cal" switch to set the motor displacement to 160 CC. When this has been properly set, push the "scroll" switch down to move to the next screen.

SETUP: HOPPER VARIABLE

This screen is used to set the type of hopper installed on the machine. Use the "cal" switch to toggle between fixed and variable hoppers. When this set for your machine, push the "scroll" switch down to move to the next screen.

SETUP: UNITS ENGLISH

This screen is used to set the display units to either english or metric. Use the “cal” switch to toggle between english and metric units. When this set for your machine, push the “scroll” switch down to move to the next screen.

SETUP: JOYSTICK Actual 0.0%

This screen is the entry screen for calibrating the joystick. It should say 0.0% with the stick in neutral. If the stick is pushed full forward, the reading should change to 100% and if it pulled fully back into reverse, the reading should change to -100%. If it does not at any of these positions, place the stick in neutral. Be sure it is in neutral and then push the “cal” switch. **Once you have pushed the “cal” switch you must complete the sequence or you will have lost the existing calibration of the joystick.** When you push the “cal” switch, the screen will change to

SETUP: JOYSTICK Neutral 2.4 volts

Push the “cal” switch to calibrate the neutral position. The display will change to

SETUP: JOYSTICK forward 4.4 volts

Push the stick full forward, the reading should change to approximately 4.4 volts. When you have the stick fully forward, push the “cal” switch to calibrate the full forward position of the control stick. The display will change to

SETUP: JOYSTICK reverse 0.7 volts

Pull the stick to the full reverse position, the reading should change to approximately 0.7 volts. When you have the stick fully rearward, push the “cal” switch to calibrate the full reverse position of the control stick. The display will change to

SETUP: JOYSTICK Actual 0.0%

When you have finished calibrating the joystick, push the “scroll” switch to change to the next screen.

SETUP: GATE OPENING Maximum: 4.00 inches

This screen is used to set the maximum gate opening for the front hopper. Standard machines have a 4 inch gate opening and big chippers have a 5 inch gate opening. If the maximum gate opening is set incorrectly for the machine the application rate will be off. Use the “cal” switch to toggle between 4 inch and 5 inch gate opening. When this is set for the machine, push the “scroll” switch down to move to the next screen.

SETUP: RIGHT NULL Actual: 0.00 inches

This screen is used to set the actual closed position of the right gate. Be sure that the gate is actually closed. This number should read 0.00 inches, if this number is not 0.00, set it to 0.00 using the “cal” switch. When it is set to this value, push the “scroll” switch to move to the next screen.

SETUP: RIGHT SCALE Actual: 0.00 inches

This screen is used to set the actual open position of the right gate. The number will read 0.00 inches until the right gate override is actuated. While holding the right gate override the number should read 4.00 inches. If it does not read 4.00, first visually verify that the gate is actually fully open. After verification, while holding the right gate override, press the CAL switch to set the value to 4.00 inches. When the right gate override is released, the number on the screen should go back to 0.00.

SETUP: LEFT NULL Actual: 0.00 inches

This screen is used to set the actual closed position of the left gate. Be sure that the gate is actually closed. This number should read 0.00 inches, if this number is not 0.00, set it to 0.00 using the “cal” switch. When it is set to this value, push the “scroll” switch to move to the next screen.

SETUP: LEFT SCALE Actual: 0.00 inches

This screen is used to set the actual open position of the left gate. The number will read 0.00 inches until the left gate override is actuated. While holding the left gate override the number should read 4.00 inches. If it does not read 4.00, first visually verify that the gate is

actually fully open. After verification, while holding the left gate override, press the CAL switch to set the value to 4.00 inches. When the left gate override is released, the number on the screen should go back to 0.00.

 WARNING
<p>Never put hands in between gate and spread roll or gate and rear of hopper to clear obstruction. The gate could move at any time and cause severe injury.</p>

SETUP: RIGHT OPEN

0.900 amps

Use the “cal” switch to adjust the current up or down to increase or decrease the speed at which the right gate opens. Adjusting this value to high will cause the gates to hunt around the desired gate opening. Adjusting this value to low will cause a delay of the gate opening.

SETUP: RIGHT CLOSE

0.950 amps

Use the “cal” switch to adjust the current up or down to increase or decrease the speed at which the right gate closes. Adjusting this value to high will cause the gates to hunt around the desired gate opening. Adjusting this value to low will cause a delay of the gate closing.

SETUP: LEFT OPEN

0.900 amps

Use the “cal” switch to adjust the current up or down to increase or decrease the speed at which the left gate opens. Adjusting this value to high will cause the gates to hunt around the desired gate opening. Adjusting this value to low will cause a delay of the gate opening.

SETUP: LEFT CLOSE

0.950 amps

Use the “cal” switch to adjust the current up or down to increase or decrease the speed at which the left gate closes. Adjusting this value to high will cause the gates to hunt around the desired gate opening. Adjusting this value to low will cause a delay of the gate closing.

SETUP: GATE OPEN HOLD

DISTANCE: 18.0 inches

This screen is used to set the delay of the right gate on a variable hopper. This value should be set to 18.0. The computer would wait until the chipspreader travels an additional 18 inches before the right gate will open. The left gate is not affected by changing this number. Use the "Cal" switch to adjust the delay to achieve a straight starting line. The right spread roll delay will adjust with the gate hold settings.

SETUP: GATE SHUT HOLD

DISTANCE: 18.0 inches

This screen is used to set the delay of the right gate on a variable hopper. This value should be set to 18.0. The computer would wait until the chipspreader travels an additional 18 inches before the right gate will close. The left gate is not affected by this number. Use the "Cal" switch to adjust the delay to achieve a straight starting line. The right spread roll delay will adjust with the gate hold settings.

SETUP: SAVE AND EXIT

Press Save to Exit

Press the “Save” button to save any changes that were made or press the “Scroll” switch down to exit without saving.

APPENDIX C

COMPUTER SERVICE SCREENS

Service Screens

The service screens are entered by holding the “scroll” switch either up or down while turning the ignition key on. The first four screens are the same as the “Operator Screens” described under “OPERATOR SCREENS” but will be repeated here.

CAUTION: When in the service screens, all interlocks are disabled and it is possible to open the gates in the manual mode while standing still.

20.0	3/8	400
lb/yd²	Chip	fpm

This screen shows the application rate set point, aggregate preset and the speed set point when standing still.

This is the screen that will come up when the ignition is turned on and the engine is started, while holding the “scroll” switch either up or down. To move to the next screen, push the scroll switch down.

100°F	60 PSI	15%
WATER	OIL	FUEL

This screen shows the engine coolant temperature on the left, the engine oil pressure in the center, and the fuel remaining in the fuel tank on the right. To move to the next screen, push the scroll switch down.

100°F	2200 RPM	13.8 V
HYD OIL	ENGINE	BATTERY

This screen shows the hydraulic oil temperature on the left, the engine rpm in the center, and the system voltage on the right side. To move to the next screen, push the scroll switch down.

120.8	7550 FT
ENGINE	CHIPPED

This screen shows the hours on the machine on the left side, and the feet chipped on the right side. To move to the next screen, push the scroll switch down to move to the first real service screen

SERVICE: RIGHT NULL
Actual: 0.0 inches

This screen shows the actual position of the right gate. Push the scroll switch down to move to the next screen.

SERVICE: LEFT NULL
Actual: 0.0 inches

This screen shows the actual position of the left gate. Push the scroll switch down to move to the next screen.

SERVICE: Aggre. Last
Status: De-activated

This screen shows the position of the “Size” switch. Push the “Size” switch down and the display should change to Activated until the switch is released. Push the scroll switch down to move to the next screen.

SERVICE: Aggre. Next
Status: De-activated

This screen shows the position of the “Size” switch. Push the “Size” switch up and the display should change to Activated until the switch is released. Push the scroll switch down to move to the next screen.

SERVICE: Appl Rate-
Status: De-activated

This screen shows the position of the “Rate” switch. Push the “Rate” switch down and the display should change to Activated until the switch is released. Push the scroll switch down to move to the next screen.

SERVICE: Appl Rate+
Status: De-activated

This screen shows the position of the “Rate” switch. Push the “Rate” switch up and the display should change to Activated until the switch is released. Push the scroll switch down to move to the next screen.

SERVICE: Cal Rate-
Status: De-activated

This screen shows the position of the “Cal” switch. Push the “Cal” switch down and the display should change to Activated until the switch is released. Push the scroll switch down to move to the next screen.

SERVICE: Cal Rate+
Status: De-activated

This screen shows the position of the “Cal” switch. Push the “Cal” switch up and the display should change to Activated until the switch is released. Push the scroll switch down to move to the next screen.

Be sure the “Park /Drive” Mode Switch is in the park position before performing the next sequence of checks.

SERVICE: L.GATE SEL
Status: De-activated

This screen shows the position of the “Left Gate Selector” switch to the computer. Put the “Left Gate Power” switch up, and depress the “Thumb” switch. The display should change to Activated. Check that it is deactivated with each of the following scenarios. Depress the “Thumb” switch to turn the “Gates Active” light off. The display should become deactivated. Turn the “Thumb” switch back on. Push the “Left Gate Power” switch down and the display should change to deactivated. Push the scroll switch down to move to the next screen.

SERVICE: L.GATE OVER
Status: De-activated

This screen shows the position of the “Left Gate Override” switch. Push the left gate override button down and the display should change to activated as long as the button is held down and return to deactivated when the button is released. Push the scroll switch down to move to the next screen.

SERVICE: R.GATE SEL
Status: De-activated

This screen shows the position of the “Right Gate Selector” switch to the computer. Put the “Right Gate Power” switch up, and depress the “Thumb” switch. The display should change to Activated. Check that

it is deactivated with each of the following scenarios. Depress the “Thumb” switch to turn the “Gates Active” light off. The display should become deactivated. Turn the “Thumb” switch back on. Push the “Right Gate Power” switch down and the display should change to deactivated. Push the scroll switch down to move to the next screen.

SERVICE: R.GATE OVER
Status: De-activated

This screen shows the position of the “Right Gate Override” switch. Push the “Right Gate Override” button down and the display should change to activated as long as the button is held down and return to deactivated when the button is released. Push the scroll switch down to move to the next screen.

SERVICE: BRAKE INPUT
Status: De-activated

This screen shows the position of the “Service Brake” pedal. Push the “Service Brake” pedal down and the display should change to “Activated” as long as the pedal is held down. Push the scroll switch down to move to the next screen.

SERVICE: Save
Status: De-activated

This screen shows the position of the “Save” Button. Push the “Save” button down and the display should change to Activated as long as the button is held down. Push the scroll switch down to move to the next screen.

SERVICE: Setup #1
Status: De-activated

This screen shows the position of the “Memory 1” Button. Push the “Memory 1” button down and the display should change to Activated as long as the button is held down. Push the scroll switch down to move to the next screen.

SERVICE: Setup #2
Status: De-activated

This screen shows the position of the “Memory 2” Button. Push the “Memory 2” button down and the display should change to Activated as long as the button is held down. Push the scroll switch down to move to the next screen.

SERVICE: Setup #3**Status: De-activated**

This screen shows the position of the “Memory 3” Button. Push the “Memory 3” button down and the display should change to Activated as long as the button is held down. Push the scroll switch down to move to the next screen.

SERVICE: Setup #4**Status: De-activated**

This screen shows the position of the “Memory 4” Button. Push the “Memory 2” button down and the display should change to Activated as long as the button is held down. Push the scroll switch down to move to the next screen.

SERVICE: Setup #5**Status: De-activated**

This screen shows the position of the “Memory 5” Button. Push the “Memory 5” button down and the display should change to Activated as long as the button is held down. Push the scroll switch down to move to the next screen.

SERVICE: VEH. SPEED -**Status: De-activated**

This screen shows the position of the “Speed” Switch. Push the “Speed” switch down and the display should change to Activated as long as the switch is held down. Push the scroll switch down to move to the next screen.

SERVICE: VEH. SPEED +**Status: De-activated**

This screen shows the position of the “Speed” Switch. Push the “Speed” switch up and the display should change to Activated as long as the switch is held up. Push the scroll switch down to move to the next screen.

SERVICE: RELEASE**Status: De-activated**

This screen shows the position of the “Brake Release” Switch. With the “Park/Drive” Mode selector in the park position and the engine not running, push the control stick out of neutral. The display should change to activated until the control stick is returned to neutral. Push the scroll switch down to move to the next screen.

SERVICE: BATTERY**Status: 12.3 volts**

This screen shows the condition of the battery and charging system. With the engine not running the battery voltage will be displayed. When the engine is running, the display will show the output voltage of the alternator. Push the scroll switch down to move to the next screen.

SERVICE: Front Speed**Status: 0 Hertz**

This screen shows the frequency being measured in the front motor speed feedback circuit. Push the scroll switch down to move to the next screen.

SERVICE: Left Gate**Status: 0.00 Volts**

This screen shows the voltage being measured in the left gate feedback circuit. Push the scroll switch down to move to the next screen.

SERVICE: Right Gate**Status: 0.00 Volts**

This screen shows the voltage being measured in the right gate feedback circuit. Push the scroll switch down to move to the next screen.

SERVICE: Joystick**Status: 0.00 Volts**

This screen shows the voltage being measured in the joystick circuit. 0.0 volts is the neutral position with +4.8 volts and -4.8 volts being the full forward and full reverse positions respectively. Push the scroll switch down to move to the next screen.

SERVICE: Forward**Status: 0.00 Amps**

This screen shows the current to the forward solenoid of the pump. Push the scroll switch down to move to the next screen.

SERVICE: Reverse**Status: 0.00 Amps**

This screen shows the current to the reverse solenoid of the pump. Push the scroll switch down to move to the next screen.

SERVICE: Front Motor

Status: 0.00 Amps

This screen shows the current to the front motor in either a 2WD or a 4WD machine. Push the scroll switch down to move to the next screen.

SERVICE: Rear Motor

Status: 0.00 Amps

This screen shows the current to the rear motor in a 4WD machine. Push the scroll switch down to move to the next screen.

SERVICE: Left Close

Status: 0.00 Amps

This screen shows the current to the left gate closing solenoid. Push the scroll switch down to move to the next screen.

SERVICE: Left Open

Status: 0.00 Amps

This screen shows the current to the left gate open solenoid. Push the scroll switch down to move to the next screen.

SERVICE: Right Close

Status: 0.00 Amps

This screen shows the current to the right gate closing solenoid. Push the scroll switch down to move to the next screen.

SERVICE: Right Open

Status: 0.00 Amps

This screen shows the current to the right gate open solenoid. Push the scroll switch down to move to the next screen.

2 hrs

0 ft

ENGINE

CHIPPED

From this screen, scrolling down will bring you back into the service screens, while scrolling up 3 times will take you back to the top operating screen.

APPENDIX D

SYSTEMS STARTUP AND ADJUSTMENTS

Hydrostatic System Startup

After any work has been done on the hydrostatic ground drive system which involved opening up the circuit in any way, the following startup procedure should be used.

1. Jack the machine up and securely support on stands with all four wheels off the ground.
2. Disconnect the 50 pin connector at the engine, so that the engine can only be cranked and cannot be started. (Fig. 16)
3. Disconnect pump stroker at the pump.

! WARNING

Be certain that machine is securely supported on stands. Wheels will be rotating under power & if they contact the ground or debris becomes lodged between the wheels & ground, the chippers could drive off the stands.

4. Insert a 600 psi gage (with a size 10 male boss end) in port "G" on the drive pump (Fig. 24).

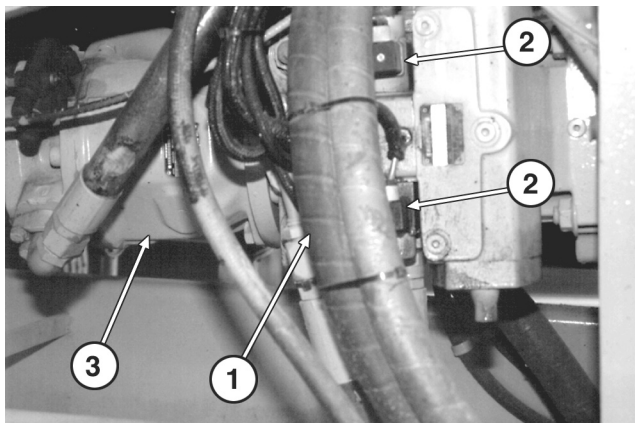

Figure 15. Hydrostatic Pump

1. Hydrostatic Pump
2. Fwd & Rev Solenoids
3. 1st Implement Pump

5. Make sure the gate valve, (Fig 17) in the suction tube is turned fully open (counterclockwise) with sleeve and handle installed. Do not attempt to start the engine with the gate valve closed. This will block the flow to the pumps and cause cavitation.

! CAUTION

Do not crank engine with gate valve closed. Doing so will cause damage to the hydraulic pumps.

6. Turn ignition key "on" and place the throttle switch in the "idle" position. Turn key to "start" and crank engine with starter until seeing at least 40 to 60 psi on the charge pressure gage.

DO NOT CRANK FOR MORE THAN 30 SECONDS.

Wait at least 2 minutes before cranking again. If no pressure reading can be obtained after 2 or 3 attempts, the starter may not be cranking the engine fast enough to develop charge pressure.

7. Hook up the 50 pin connector.
8. Turn ignition key to "start" and release, letting engine run at idle. Observe the charge pressure for a reading within 30 seconds. Once a reading is seen, allow the engine to idle for about 10 minutes.

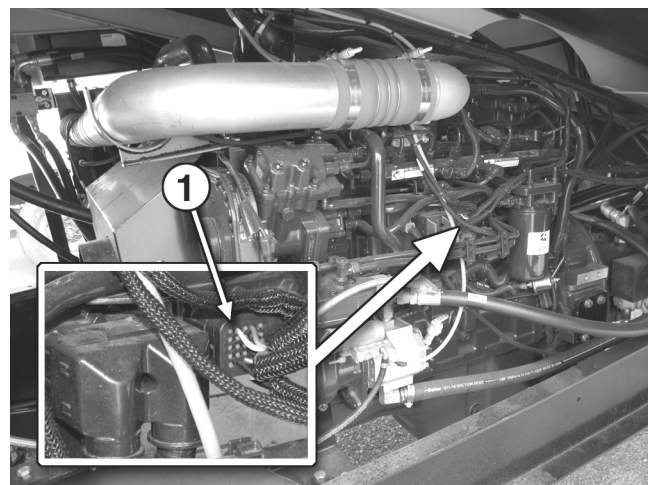

Figure 16. Engine Left Side

1. 50 Pin Connector

During filling of all lines and components, the charge pressure can surge between 50 and 500 psi. As the system fills, surging will decrease and the charge pressure should settle down to a steady reading.

WARNING

Be certain that machine is securely supported on stands. Wheels will be rotating under power.

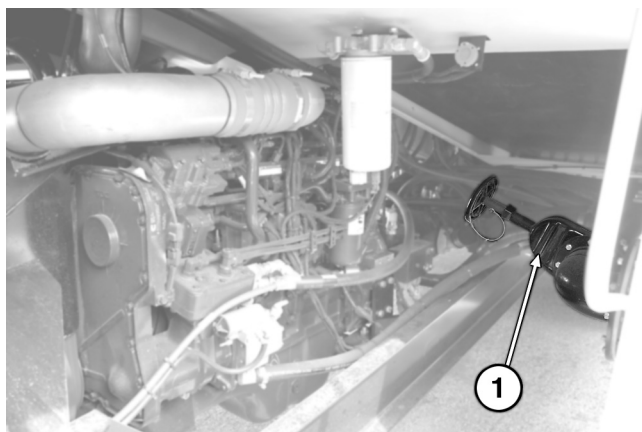

Figure 17. Gate Valve

1. Gate Valve

9. Shut down engine, remove all gages and replace all plugs or caps. Recheck fluid levels after 15 minutes and add as necessary to bring to level of the sight eye in the tank.

Gate Transducer Adjustment

1. Place the Drive/Park selector in “PARK”
2. Hold the CAL switch down and start the engine. Release the CAL switch once the computer beeps three times. This will access the computer set up screens.
3. Scroll down until the display reads RIGHT GATE NULL. This value should be around 0.0. If it is not, verify that the right gate is closed. There should be 1/16” between each gate and the spreadroll. If necessary, disconnect the connectors from the right gate valve and power the gate shut using the manual override. Once the gate is shut, press the CAL switch down to set the closed value (null).
4. Once the null is set, scroll down to the next screen, RIGHT GATE SCALE. Hold the right gate override pushbutton down and monitor the display. The display should show 4.00” while the override is activated. If it does not, verify that the gate is fully open. Once the gate is fully opened, press the CAL switch down while holding the override to set the opening to 4.00” When the gate override is released, the display should go back to 0.00”
5. Scroll down to the next screen, LEFT GATE NULL. Follow the procedure outlined above to set the null and the scale for the left gate.

6. Once both gates have been set, scroll down to the last screen of the set up screens and press the save pushbutton to save any changes that were made.

It is recommended to try and set the gates using the computer set up screens prior to physically making any adjustments to the potentiometer itself. If the gates cannot be set using the set up screens, or a new gate potentiometer is to be installed, the following procedure should be used. Refer to Figs 18,19 & 20.

1. Place the Drive/Park selector in “PARK”.
 2. Start the engine and run it at about 1000 rpm.
 3. Extend both hoppers approximately 2 feet each and shut the engine off.
 4. To insure that the gates are fully closed, swap the connectors on the open and close solenoid valve (Fig 19) and restart the engine. Depress the gate override button which will fully close the gates. While holding the override button down, shut the engine off. There should be 1/16” between each gate and its spread roll.
 5. Return the connectors to their correct positions.
 6. Enter the Set up access screens by holding the “Cal” switch down while turning the key on. Do not start the engine. Scroll down to the left gate null setting, and set the null to zero by depressing the “Cal” switch. The screen should change to 0.0. Then scroll down to the save screen and save the value.
 7. Using needle probes on a digital voltmeter, measure the voltage between the red and black wires at the gate transducer (Fig 20). The value should be 5.0 volts DC. Next, check the voltage between the blue and black wires. This value should be between 0.5 and 1.5 volts DC.
 8. If the value measured in step 7 is not within the specified tolerance, remove the transducer cover on the hopper.
 9. Loosen the transducer mounting bolts and rotate the transducer as necessary to get the 0.5-1.5 volt DC reading.
 10. Retighten the mounting bolts.
 11. Recheck the reading.
 12. Start the engine and depress the gate override button to fully open the gates. While depressing the override button, shut the engine off. The gates should remain fully open. Turn the key back on and measure the voltage between the blue and black wires. The voltage should be 3.5 to 4.5 volts DC. Restart the engine and let the gates close and recheck that the closed value is still within the specified range of 0.5 -1.5 volts.
- If it is, enter the set up screens while starting the engine and scroll down to the appropriate gate scale screen.

13. Depress the override button to fully open the gates and then depress the cal switch. The reading should change to 4.00.

14. Release the override button and scroll up to the appropriate "Gate Null" screen to check the reading. If it is no longer at "0", depress the override button and scroll down to the appropriate "Gate Scale" screen. Depress the override button and while depressing the override button, depress the "Cal" button to set the scale.

15. Repeat these two steps as required until the readings get to "0" and "4" or until they no longer change.

16. Upon completion, scroll to the save screen and exit set up by depressing the "Save" button.

17. Repeat this procedure for the other gate, if its transducer has also been changed.

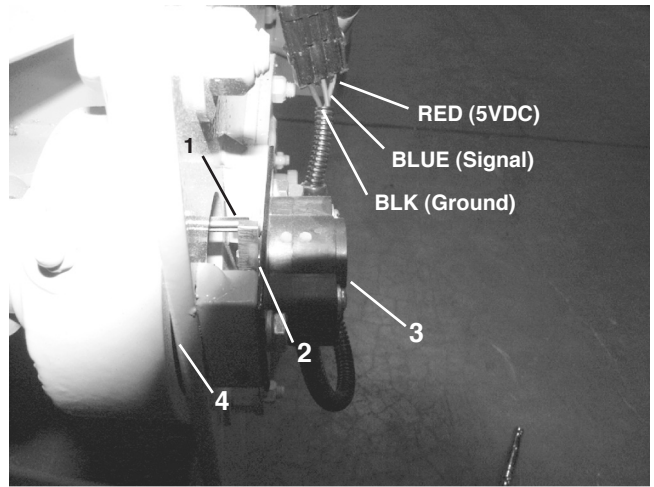

Figure 20. Left Hopper Transducer

- 1. Drive Pin
- 2. Lever Arm
- 3. Transducer
- 4. Bearing

! WARNING

Never put hands in between gate and spread roll or gate and rear of hopper to clear an obstruction. The gate could move at any time and cause severe injury.

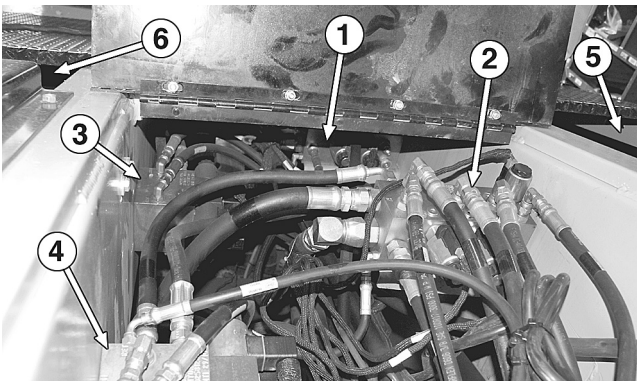

Figure 18. Gate/Hopper/Conveyor/Auger/Spreadroll Manifolds

- 1. Left Conveyor/Auger/Spreadroll
- 2. Right Conveyor/Auger/Spreadroll
- 3. Left Gate/Hopper Manifold
- 4. Right Gate/Hopper Manifold
- 5. Left Conveyor
- 6. Right Conveyor

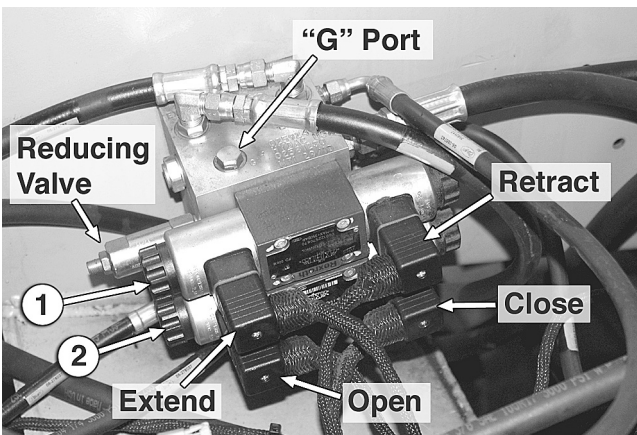

Figure 19. Right Gate Solenoid

- 1. Hopper Solenoid
- 2. Gate Solenoid Valve

Air Pressure Adjustments

1. Set the main pressure regulator at 80 psi. (Fig 21)

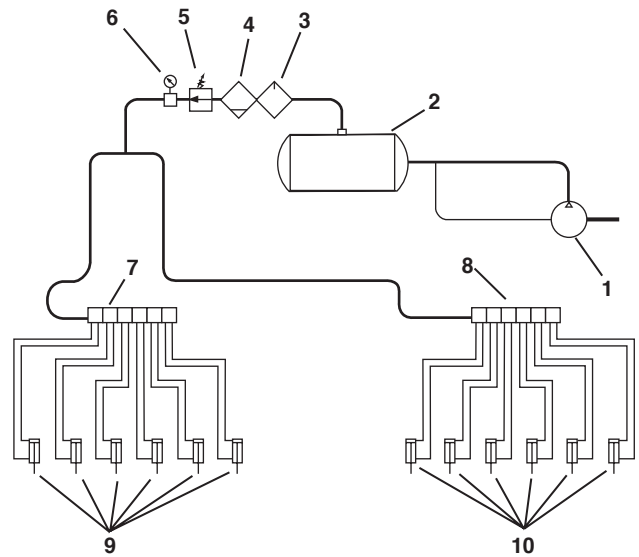

Figure 21. Air System

- 1. Compressor
- 2. Reservoir
- 3. Air Oiler
- 4. Water Separator
- 5. Main Regulator
- 6. Main Pressure Gage
- 7. Left Valve Bank
- 8. Right Valve Bank
- 9. Left 1 FT Gate Cylinders
- 10. Rt 1 FT Gate Cylinders

Pressure Adjustments

Pressure Settings For Hydrostatic Drive Pump (Rexroth AA4VG125 Pump)

The pressure settings consist of two (2) high pressure cross port relief valves (forward and reverse) and the pressure override for the AA4VG125 pump. The adjustment procedure is as follows:

1) Install 10,000 psi pressure gages in ports M_A and M_B located on the top side of the pump. These ports are -04 SAE O-ring. The pressure gages should be installed with enough hose to see the gage without getting under the machine.

 WARNING
<p>Do not go under the machine while the engine is running. The machine could move causing severe injury or death.</p>

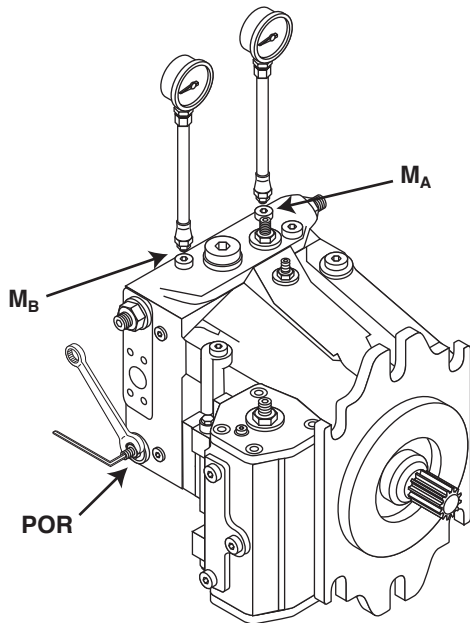

Figure 22. POR Setting

2) The pressure override (POR) should be turned all the way **IN** to be able to obtain the highest possible pressure cutoff setting. Turn screw in (clockwise) until resistance is encountered. Do not force the adjustment past this point. The POR adjustment is located below the curb side high pressure port. The adjustment will require a 4mm allen wrench and a 13mm box wrench. The protective plastic cover may have to be removed to gain access to the POR adjustment.

3) Set the forward and reverse high pressure cross-port relief valves (Relief valves A & B) to approximately 7,000 psi. To do this, first disable the parking brake release circuit by disconnecting the Weatherpack connector at the parking brake release solenoid. This solenoid is located on the hydraulic manifold under the center deck cover below the operator's station. The brake release solenoid is the forward most coil towards the curbside of the machine. Disabling this circuit will insure the chipperspreader will not move while checking pressures. On 4WD units, the rear hoses must be capped

to prevent the rear wheels from turning. Disconnect the two rear drive hoses at the drive pump and install 16MB caps on the adapters and 16MB plugs in the hose ends. Once the parking brake release has been disabled, unhook the brake pressure switch, if equipped. The switch is located on the hose coming from the foot pedal. Apply foot pedal brake and push joystick forward developing maximum system pressure. Check reading on gage in port M_A for forward high pressure. Should the pressure need adjusting, you may have to remove the protective plastic cover located above the high pressure port on the street side of the pump. Turn adjusting screw in (clockwise) to increase relief setting. This adjustment requires a 5mm allen wrench and a 17mm box wrench. Once forward cross-port relief valve (relief valve A) has been set to 7000 psi, repeat above procedure for reverse (relief valve B). Adjustment for this relief is located above the curb side high pressure port.

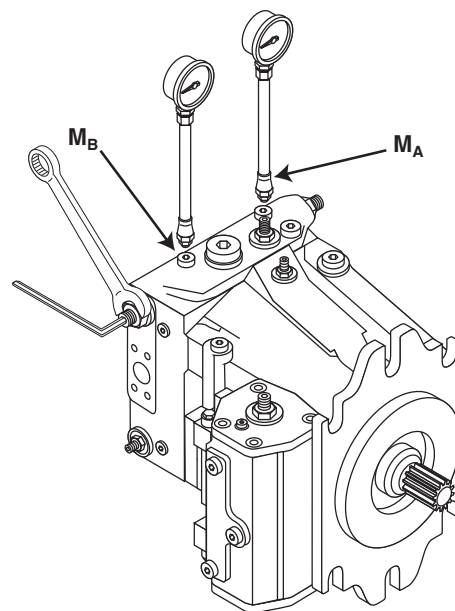



Figure 23. High Pressure Relief Setting

 CAUTION
<p>When setting the two high pressure cross-port relief valves DO NOT leave the pump on stroke for more than a few seconds at a time. The flow is being short circuited from the pump inlet and a lot of heat is being generated.</p>

The Correct procedure is to:

Put the pump on stroke and see where the relief valve pressure setting is at but not leaving the pump on stroke for more than a few seconds

Put the pump to neutral

Make an adjustment to the relief valve

Put the pump on stroke again and see where the pressure level is at.

Repeat the above process as many times as necessary until the correct pressure level is obtained.

4) Once the two high pressure relief valves set correctly for forward and reverse, set the Pressure Override Valve to 6500 psi. To do this, adjust the POR screw out (counter clockwise) until the high pressure reads 6500 psi. The POR adjustment is the same screw that was turned in full in step 2. There is only one setting for this relief that controls forward and reverse.



CAUTION

When making the pressure override adjustment, the pump should be put on stroke only for a few seconds at a time until you are sure that the pressure cutoff setting is **Below** the setting of the two high pressure cross-port relief valves.

Once the pressure override setting is below that of the two high pressure cross-port relief valves, the pump can be left on stroke without any problems as there will be no flow across the high pressure cross-port relief valves.

Remove the gages.

Setting the Charge Pressure

1) Install 600 PSI gage in “G” port on the drive pump (Fig. 24). The gage will require a size 10 male boss end to plumb to the gage port. With engine at low idle, the charge pressure should read 400 psi.

2) If the pressure is below 380 or above 420, an adjustment should be made to the charge pressure relief valve. To access the relief valve adjustment, you may have to remove the protective plastic cap located on the top side of the pump beside the port marked “G”. Using a 17mm box wrench with a 5mm allen wrench, loosen the jam nut and turn set screw clockwise if the pressure is low. If the pressure is high, loosen the jam nut and turn set screw counterclockwise. One turn is equal to 55 psi.

Remove the gage.

Pressure Settings For Auxiliary Pumps (Rexroth A10VO74 and AA10VO100D)

The variable hopper chipspreader utilizes two variable displacement pumps to supply flow to hydraulic functions. These pumps are mounted piggyback on the through drive of the hydrostatic drive pump. Flow for the right conveyor, right auger, right spreadroll, the right gate cylinder and the right hopper extend/retract cylinder is supplied by the front pump. Flow for the left functions and the hitch functions is supplied by the rear pump. The pumps each have an internal high pressure relief setting and a standby or margin pressure setting. The high pressure relief should be set to 3000 psi on both pumps. The standby pressure should be set to 400 PSI on both pumps.

Relief Valve Settings

Setting the Front Pump

1) Install a 1000 psi gage, with a shutoff valve in the port marked “G” on the right gate manifold located between the conveyors (Fig 25). This port is SAE 04 and requires a 9/16" wrench to remove the plug.

2) Disconnect the electrical connectors from the gate valves (Fig 27). Make sure that all conveyor, auger and spreadroll switches are all in the “off” position before starting the engine. Make sure the shutoff valve is shut. Failure to do so could result in a blown gage. back the standby pressure relief valve out 2 turns. Start the engine and run it at low idle. Open the shutoff and monitor the gage pressure.

3) To make an adjustment, use a 17mm wrench to remove protective cap from set screw located to the rear of each pump on the curbside of the chipspreader. The standby pressure adjustment is the higher of the two adjustments at the rear of the pump (Fig 26 Ref 4).

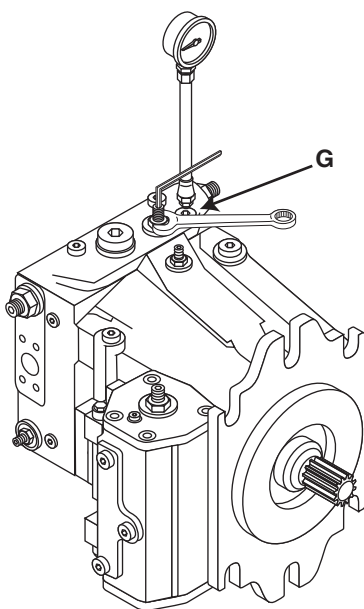

Figure 24. Charge Pressure Adjustment

4) Loosen the jam nut on the front pump and turn the set screw until the pressure reads 400 psi on the gage. Tighten the jam nut. Shut the engine off.

5) Install a 5000 psi gage in the port marked “G” on the right gate manifold (Fig 27) located between the conveyors. On the front pump back the high pressure relief valve out about 2 turns.

6) With the engine running at half throttle, press the right hopper retract switch to retract the hopper until it hits the stop. While holding the switch to the “IN” position monitor the gage pressure.

7) To make an adjustment, use a 17mm wrench to remove protective cap from relief set screw located to the rear and curbside of the pump. Of the two adjustments at this location, the high pressure relief is the lower one of the two (Fig 26 Ref 1).

8) Loosen the jam nut and turn the set screw clockwise using a 5mm allen wrench until the pressure reads 3000 psi on the gage. Tighten the jam nut and replace protective cover once the pressure is set. shut off engine.

9) Remove gage and reinstall the 1000 psi gage with the shutoff closed. Restart engine and let it idle. Open the shutoff valve and verify that the standby pressure is still at 400 psi and adjust if necessary.

10) Reconnect the electrical connectors from the gate valves (Fig 27).

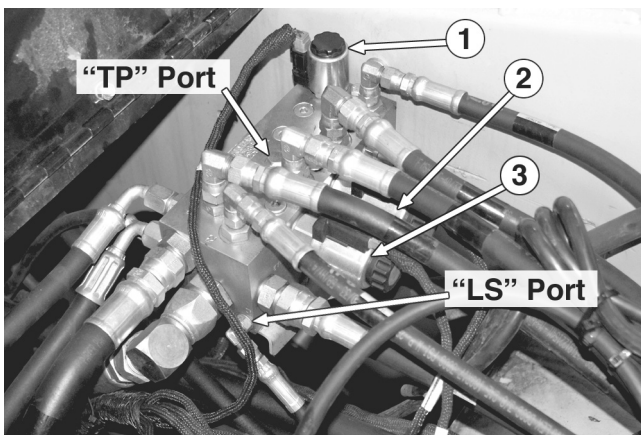

Figure 25. Conveyor/Auger/Spreadroll Manifold

- 1. Spreadroll Valve
- 2. Auger Valve
- 3. Conveyor Valve

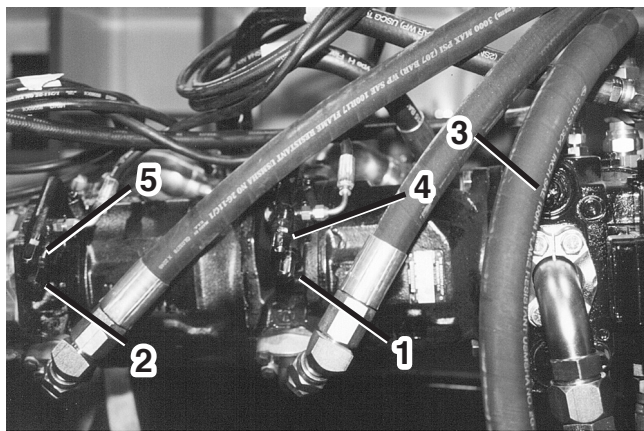

Figure 26. Pumps

- 1. Front Pump Relief Valve
- 2. Rear Pump Relief Valve
- 3. Main Hydrostatic Pump
- 4. Front Standby Pressure
- 5. Rear Standby Pressure

⚠ CAUTION

Do not set pressure above 3100 psi. The hydraulic components are rated for 3100 psi. Failure of these components could occur at system pressures above 3100 psi.

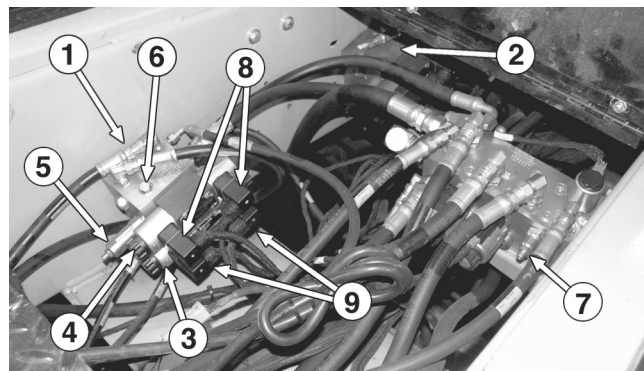

Figure 27. Gate/Hopper Manifolds

- 1. Right Gate/Hopper Manifold
- 2. Left Gate/Hopper Manifold
- 3. Gate Valve
- 4. Hopper Valve
- 5. Reducing valve
- 6. "G" Port
- 7. Spreadroll Speed Adjust
- 8. Elect Connectors - Hopper Vlv
- 9. Elect Connectors - Gate Valve

Setting the Rear Pump

1) Install a 1000 psi gage, with a shutoff valve in the port marked “G” on the left gate manifold (Fig 27) located between the conveyors. This port is SAE 04 and requires a 9/16" wrench to remove the plug.

2) Make sure that all of the conveyor, auger and spreadroll switches are all in the “OFF” position before starting the engine. Make sure the shutoff valve is shut. Failure to do so could result in a blown gage. Back the standby pressure relief valve on the pump out 2 turns.

Start the engine and run it at low idle. Open the shutoff and monitor the gage pressure.

3) To make an adjustment, use a 17mm wrench to remove protective cap from set screw located to the rear of the pump on the curbside of the chipsreader. The standby pressure adjustment is the higher of the two adjustments at the rear of the pump (Fig 26, Ref 4)

4) Loosen the jam nut on the rear pump and turn the set screw until the pressure reads 400 psi on the gage. Tighten the jam nut. Shut the engine off.

5) Install a 5000 psi gage in the port marked “G” on the left gate manifold (Fig 27) located between the conveyors. On the rear pump back the high pressure relief valve out about 2 turns.

6) With the engine running at half throttle, press the left hopper retract switch and monitor the gage.

7) To make an adjustment, use a 17mm wrench to remove protective cap from relief set screw located to the rear and curbside of the pump. Of the two adjustments at this location, the high pressure relief is the lower one of the two (Fig 26, Ref 1).

8) Loosen the jam nut and turn the set screw clockwise using a 5mm allen wrench until the pressure reads 3000 psi on the gage. Tighten the jam nut and replace protective cover once the pressure is set. Shut off engine.

9) Remove gage and reinstall the 1000 psi gage with the shutoff closed. Restart engine and let it idle. Open the shutoff valve and verify that the standby pressure is still at 400 psi and adjust if necessary.

10) Remove gage and reinstall conveyor hose in A1 port of conveyor manifold.

Pressure/Flow Settings For Actuator Valving

(Functions supplied by pressure compensating auxiliary pump)

Note: Other than individual circuits which require reduced pressure for mechanical purposes, the main system relief is set at the pump.

Hopper Reducing Valves

The relief setting for the hopper reducing valves (left and right) should be set to 1300 psi.

1) Install 2000 psi gage in “G” port of hopper manifold (Fig 29) located between the conveyors (Fig 28). This port is SAE 04 MB and requires a 3/16 allen wrench to remove the plug.

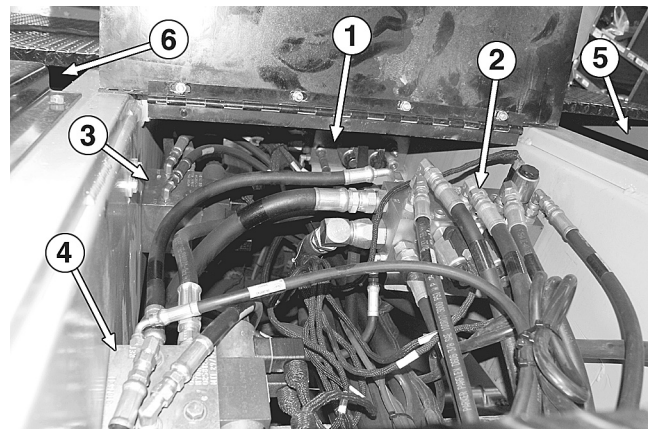

Figure 28.
Gate/Hopper/Conveyor/Auger/Spreadroll Manifolds

- | | |
|---------------------------------------|-------------------------------|
| 1. Left
Conveyor/Auger/Spreadroll | 3. Left Gate/Hopper Manifold |
| 2. Right
Conveyor/Auger/Spreadroll | 4. Right Gate/Hopper Manifold |
| | 5. Left Conveyor |
| | 6. Right Conveyor |

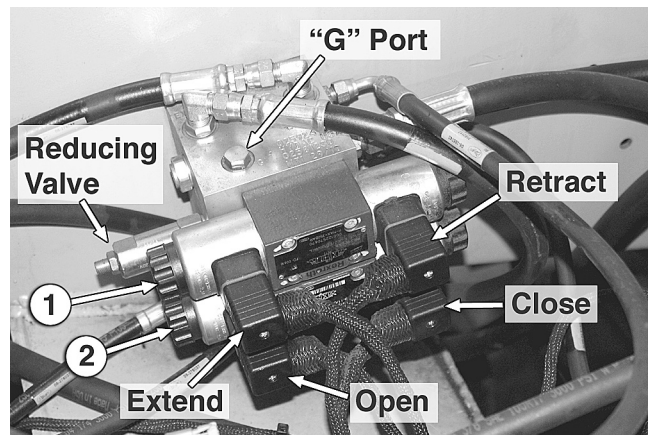

Figure 29. Hopper/Gate Manifold

- | | |
|--------------------------|------------------------|
| 1. Hopper Solenoid Valve | 2. Gate Solenoid Valve |
|--------------------------|------------------------|

2) With engine at high idle, depress and hold the left gate override push-button and monitor pressure. If pressure is below 1200 or above 1400, an adjustment should be made.

3) To adjust pressure, use 3/4” box wrench to loosen jam nut on set screw located on the reducing valve (Fig 29) mounted between the conveyors (Fig 28). If pressure is low, turn set screw clockwise. If pressure is high, turn set screw counterclockwise. Retighten jam nut.

4) Repeat above procedure for the right gate reducing valve (Figs 28 & 29).

Spreadroll Speed Adjustment

The spreadrolls are each to be set at 96 rpm.

Right Spreadroll

1) Insure park/drive switch is in the park position and the right gate and right spreadroll power switches are on. With engine at high idle, push joystick slightly out of neutral and depress right side of thumb switch engaging the right gate/spreadroll circuit. Time the spreadroll with a stopwatch or a low speed tachometer to determine the revolutions per minute.



Figure 30. Conveyor/Auger/Spreadroll Manifold
Spreadroll Flow Control Valve

2) To adjust the speed, loosen the jam wheel on the spreadroll flow control valve (Fig 30) located between the conveyors (Fig 31). Turn the adjusting knob clockwise to decrease the speed of the spreadroll, or counterclockwise to increase the speed. Retighten the jam wheel.

Left Spreadroll

1) Insure park/drive switch is in the park position and the left gate and left spreadroll power switches are on. With engine at high idle, push joystick slightly out of neutral and depress right side of thumb switch engaging the left gate/spreadroll circuit. Time the spreadroll with a stopwatch or a low speed tachometer to determine the revolutions per minute.

2) To adjust the speed, loosen the jam wheel on the spreadroll flow control valve (Fig 30) located between the conveyors (Fig 31). Turn the adjuster knob clockwise to decrease the speed of the spreadroll, or counterclockwise to increase the speed.

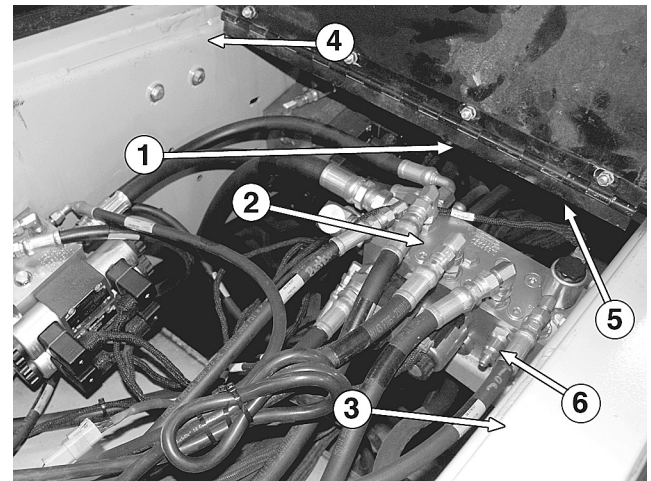

Figure 31. Spreadroll Speed Adjustment

1. Lt. Conveyor/Auger/Spreadroll
2. Rt. Conveyor/Auger/Spreadroll
3. Left Conveyor
4. Right Conveyor
5. Left Spreadroll Flow Control Valve
6. Right Spreadroll Flow Control Valve

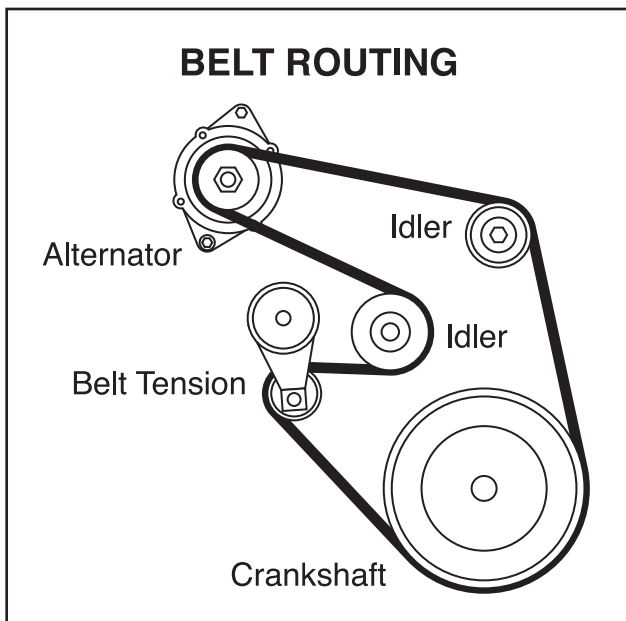

Figure 36. Engine Belt Routing

Fixed Displacement Auxiliary Pump

The fixed displacement pump (gear pump) is mounted to the back of the pressure compensating auxiliary pump. This pump supplies flow for the power steering and fan. The gear pump does not have an internal relief and relies on external valving to govern relief pressure.

Pressure Settings For Actuator Valving Supplied By Rear Auxiliary Pump

Main Relief Pressure (MPT)

The main relief pressure should be set to 1200 psi. The steering motor operates at this pressure.

1) Install 3000 psi gage in port marked “MPT” on hitch manifold located under center deck cover below operators station. This port is SAE 04 MB and requires a 1/4” allen wrench to remove plug.

2) With engine at or above 1000 rpm, press the batwing lower switch until it hits the stop. While holding the switch in the "lower" position, monitor the gage pressure.

Note: Engine must not be running to adjust set screw. When cap is removed, oil will flow through valve and spray out top of valve. Shut the engine off before proceeding to make any adjustment.

3) If the pressure is low, remove cap from top of relief valve using vise grips (Figure 33 Ref 3) and adjust set screw clockwise using a 1/4” allen wrench. If pressure is high, adjust set screw counterclockwise.

Pilot Pressure (PP)

The pilot pressure should be set to 250 psi. The hitch raise/lower function operates at this pressure.

1) Install 600 psi gage in port marked “PP” on steering/hitch manifold. This port is SAE 04 MB and requires a 1/4” allen wrench to remove plug.

2) With engine at or above 1000 rpm, monitor pressure.

Note: Engine must not be running to adjust set screw. When cap is removed, oil will flow through valve and spray out top of valve. Shut the engine off before proceeding to make any adjustment.

3) If the pressure is low, remove cap from top of relief valve using vise grips (Figure 33 Ref 4) and adjust set screw clockwise using a 1/4” allen wrench. If pressure is high, adjust set screw counterclockwise.

4) Remove gauge.

Fan Valve Pressure Setting

The fan valve relief should be set to 2000 psi. The fan motor operates at this pressure.

1) Remove hose from “M” port on the fan valve located behind the cooler (Fig 34). Cap the end of the hose and install a 3000 psi gage into port “M” on the fan valve. This port is an SAE 16 and requires a 1 1/2” wrench for the hose and cap.

2) With engine at high idle, unplug connector at the fan valve, monitor pressure. If the pressure is below 1900 psi an adjustment should be made.

3) To adjust the pressure turn off engine and adjust relief set screw on fan valve. A 9/16” box wrench is required to loosen the jam nut and a 5/32” allen wrench is required to adjust the set screw. If the pressure is low turn the set screw clockwise. If pressure is high turn the setscrew counterclockwise.

4) Restart the engine and monitor pressure. Repeat step 3 as necessary to adjust the pressure in the range of 1900 psi to 2100 psi.

5) Shut engine off. Remove gage, reinstall hose and reconnect electrical connection on fan valve.

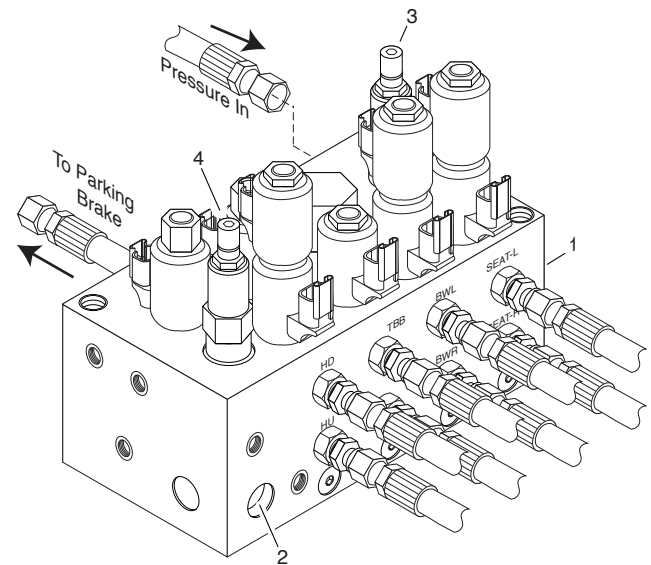

Figure 33. Hydraulic Control Assembly

- | | |
|------------------------------|--------------------------------|
| 1. Main Pressure Check Port | 3. Main Pressure Relief Valve |
| 2. Pilot Pressure Check Port | 4. Pilot Pressure Relief Valve |

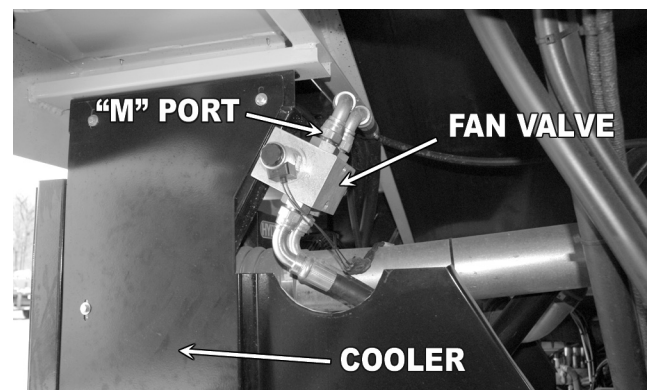

Figure 34. Fan Valve

TRUCK HITCH ARRANGEMENT

1. Trucks ranging in size from four to ten yards are handled easily by an ETNYRE Chip-Spreader.

2. An apron on the rear of each truck will be quite helpful.

3. For truck hitch arrangement, see truck hitch tow bar illustration below.

Truck Hitch Tow Bar Illustration

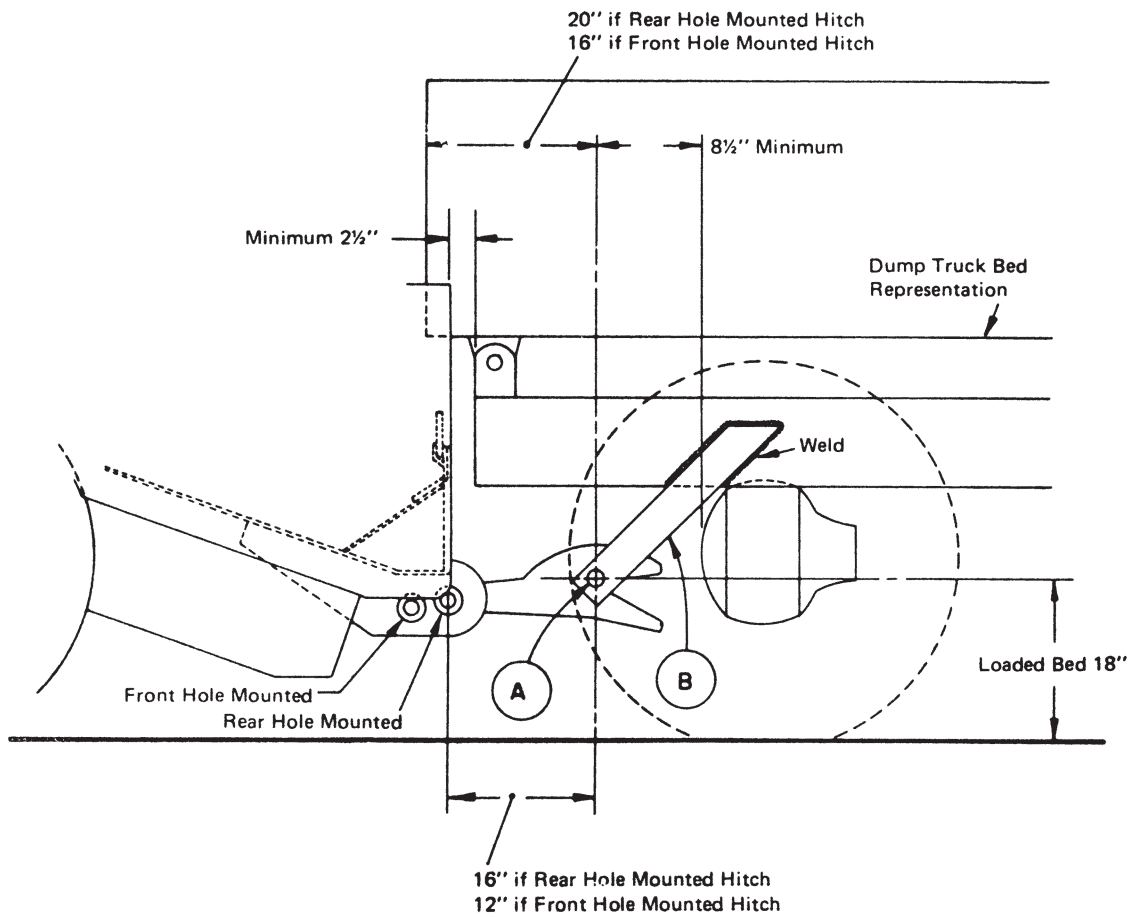

A. 3390451-Cold Rolled Round 1 3/4" dia. x 36" long

B. 3390450-Hot Rolled Flat 1/2" x 4" x 18" long (2) Req'd

LUBRICATION

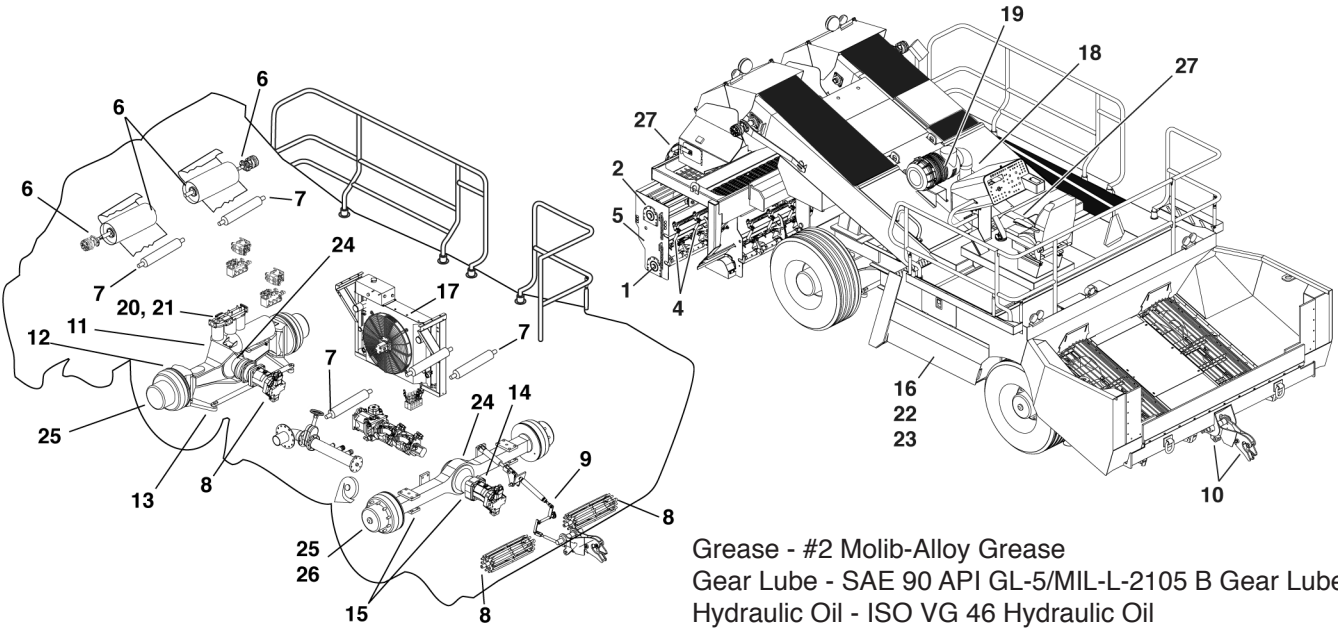

Grease - #2 Molib-Alloy Grease
 Gear Lube - SAE 90 API GL-5/MIL-L-2105 B Gear Lube
 Hydraulic Oil - ISO VG 46 Hydraulic Oil
 Lube Oil - #10 Non-Detergent Oil

MAINTENANCE

Interval	Point	Identification	No. of Points	Lubricant	Quantity
Weekly	1	Bearing-Spreadroll (Both Ends)	4	Grease	Sparingly
	2	Bearing-Auger (Both Ends)	4	Grease	Sparingly
	3	Bearing-Hopper Gate (Both Ends)	4	Grease	Sparingly
	4	Bearing-Individual Gates	A/R	Grease	Sparingly
	6	Flange Bearing-Conveyors	4	Grease	Sparingly
	7	Flange Bearing-Return Idler	12	Grease	Sparingly
	8	Bearing-Tail Pulley	4	Grease	Sparingly
	9	Bearing-Hitch Levers	4	Grease	Sparingly
	10	Shaft-Truck Hitch	4	Grease	Sparingly
	11	Shaft-Front Axle Pivot	2	Grease	Sparingly
	12	Spindle-Front Axle	4	Grease	Sparingly
	13	Tie Rod-Front Axle	6	Grease	Sparingly
	14	Bearing-Slack Adjuster (2wd only)	2	Grease	Sparingly
	15	Bearing-Camshaft (2wd only)	4	Grease	Sparingly
	16	Hydraulic Reservoir	-	Hydraulic Oil	Add When Low
	17	Hydraulic Oil Cooler	-	-	Clean A/R
	18	Engine Oil Fill	1	Engine Original	Engine Manual
	When Indicator Turns Red	19	Filter-Engine Air Intake	1	-
Yearly	20	Filter-Return*	2	-	Filter Element
	21	Filter-Suction*	2	-	Filter Element
	22	Magnet-Hydraulic Reservoir (In Tank) 1 - Clean A/R			
	23	Breather-Hydraulic Reservoir	1	-	Filter Element
	24	Differential Housing**	1 - 2wd 2 - 4wd	Gear Lube	Fill
	25	Planetary Wheel End**	2 - 2wd 4 - 4wd	Gear Lube	Fill
	26	Hub-Rear Axle (2wd only)**	2	Gear Lube	Fill
	27	Roller Chain-Power Seat (Optional)	2	Lube Oil	Sparingly

* On new machines change filter elements after first two weeks of operation. After initial change (two weeks) replace elements on an annual basis unless hydraulic system has been worked on and contamination introduced into the system. Change elements anytime it is possible that contamination has been introduced to the system.

** On new machines drain lubricant from axles after first 50 hours of operation and fill with SAE 90 API GL-5/MIL-L-2105 B gear lube. After initial change (50 hours) change lube on an annual basis.

CAUTION AND INSTRUCTION PLATES

MAINTENANCE

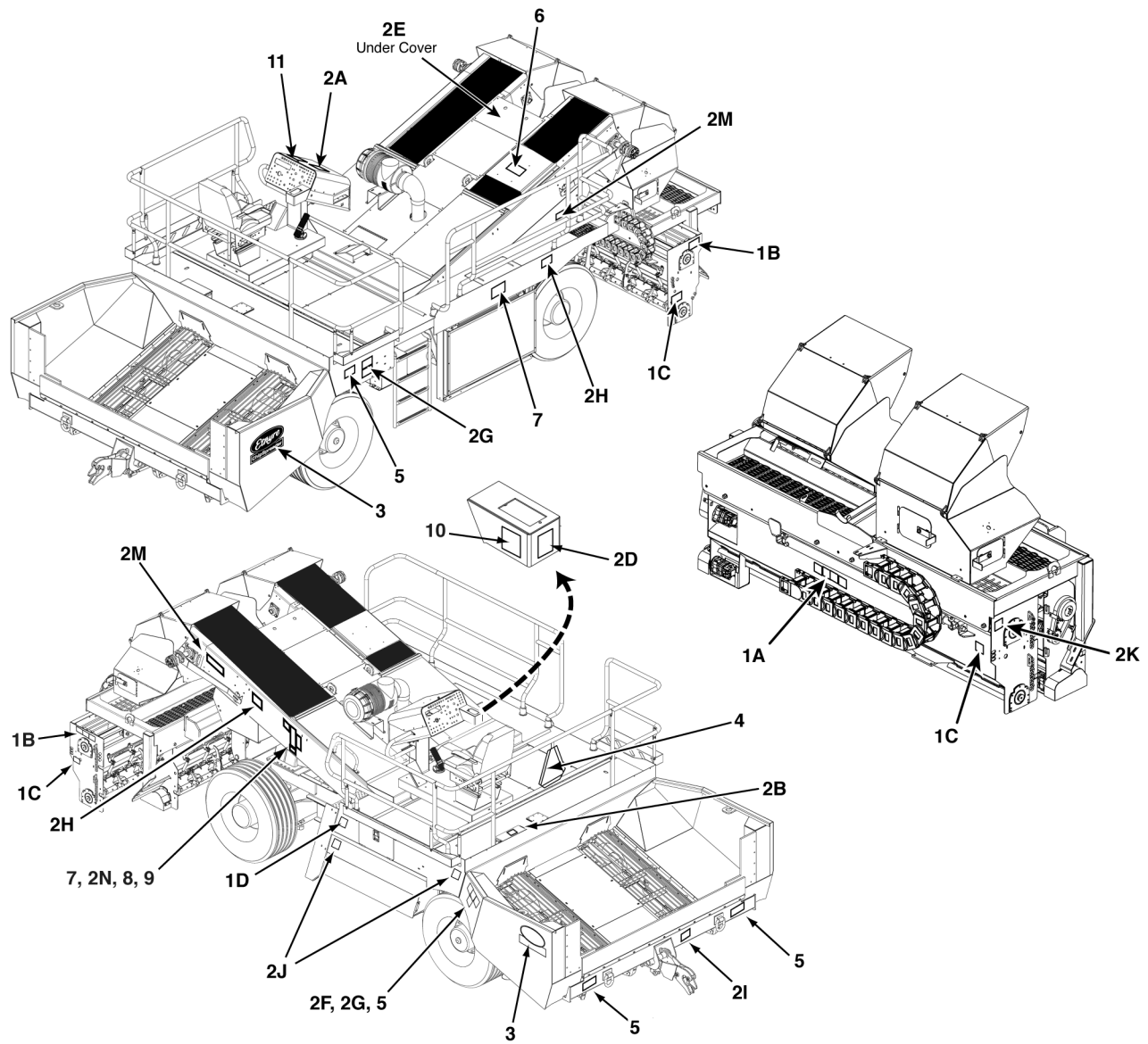

REF	PART NO.	QTY	DESCRIPTION	REF	PART NO.	QTY	DESCRIPTION
1	3102067	1	Decal Set, Chips Hopper Var.		3102065-K	1	Warning: Clear, Caution: Shields
	3102067-A	1	Warning: Auger,read,Caution: Shield		3102065-L	1	Caution: Towing
	3102067-B	2	Warning: Auger, Clear, Caution: Shields		3102065-M	2	Grease Daily
	3102067-C	6	Warning: Auger		3102065-N	1	Caution: Valve
	3102067-D	1	Lubrication Chart	3	3101999	2	Decal-Chipsreader, Fwd
2	3102065	1	Decal Set, Chipsreader Body		3102000	2	Decal-Chipsreader, Quad
	3102065-A	1	Warning: Injury, Read, Brake	4	6000758	1	Emblem-Vehicle, Slow Moving
	3102065-B	1	Warning: Fuel Tank, Fill	5	3102176	4	Decal-Warning, Pinch Point
	3102065-C	1	Warning: No Drill	6	3101717	1	Warning-Hoppers,Stay Off
	3102065-D	1	Warning: No Shift	7	3102205	2	Warning-No Passengers, No Handrails
	3102065-E	1	Anti-Freeze	8	3102346	1	Important-Hydraulic Bleed Valve
	3102065-F	1	Proposition 65 Warning	9	3103230	1	Notice-Emission Control Information
	3102065-G	2	Warning: No Drill, Caution: Towing	10	3102268	1	Warning-Ignition Switch
	3102065-H	2	Warning: Clear, Caution: Towing	11	3190516	1	Caution-Traction Boost
	3102065-J	2	Warning: Hydraulic Tank				



Something Wrong with this manual?

If you find inaccurate or confusing information in this manual, or just have a suggestion for improvement, please let us know.

Email this form to us at: sales@etnyre.com • www.etnyre.com

Mail or FAX this form to us at: E. D. ETNYRE & CO. 1333 S. Daysville Rd. Oregon, Illinois 61061 • Fax: 800-521-1107 • www.etnyre.com

Attn: Service Manager

Recommended changes from: _____

Address _____

City, State, Zip _____

Phone _____

Date Sent _____

Manual Number (upper right corner of front cover) _____

Manual Title _____

Explain the problem in the space below.

Page Number	Reference Number	Paragraph Number	Figure Number	Problem (please be specific)

COMMENT FORM