

FEATURE	DESCRIPTION	SPECIFICATION
Capacity	Tilt Out Bag Cage	8 cu.ft. 60 US Gallons (225L)
	Poly Bag	2.5 mil 30 x 38 (760 x 965)
Construction	Housing	12 Ga. (2.6) Galvanneal Steel
	Lid	14 Ga. (1.9) Galvanneal Steel
	User Door	14 Ga. (1.9) Galvanneal Steel
	Side Hinged Unloading Door	14 Ga. (1.9) Galvanneal Steel
	Hinges and Latches	Stainless Steel
	Paint	Powder Coat
Weights	Standard Mini Hid-A-Bag II	240lbs (109kg)
	(Optional) Pre-Cast Mounting Pad (HBG-3702)	395lbs (180kg) 30 x 40 x 4 (760 x 1015 x 102)

ALL SPECIFICATIONS SUBJECT TO CHANGE WITHOUT NOTICE

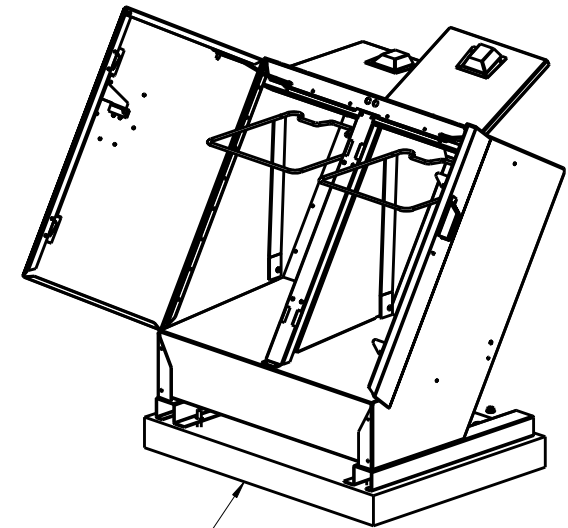

MOUNTING PAD (OPTIONAL)

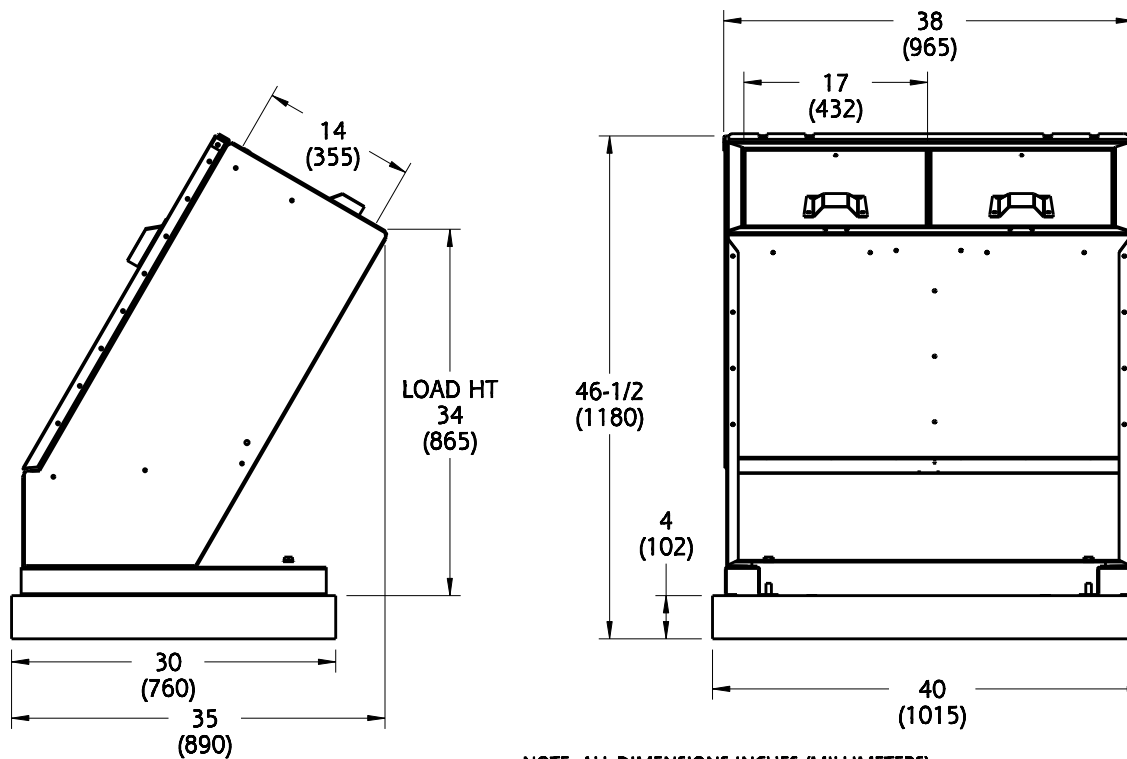
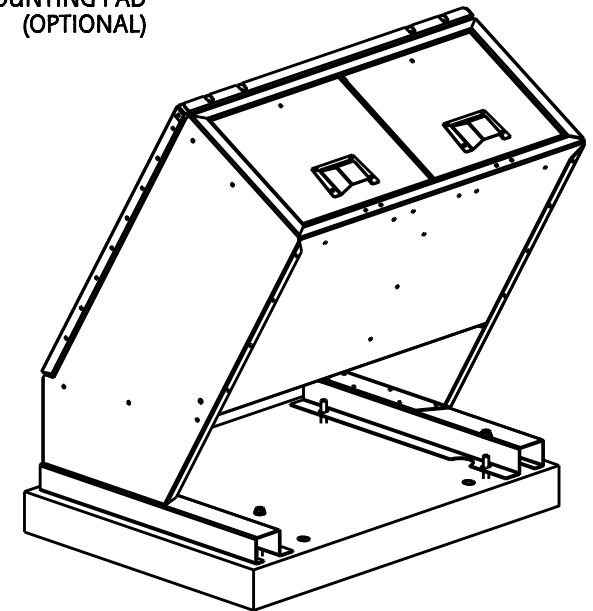

NOTE: ALL DIMENSIONS INCHES (MILLIMETERS)

TRAILER SIZE	QTY	HAUL-ALL EQUIPMENT LTD. reserves proprietary rights on this drawing or any part of the information contained thereon. This drawing shall be considered confidential material and is not to be used for competitive bidding nor for use in any procurements other than from Haul-All Equipment Ltd.	NAME HBIIM CONTAINER (STANDARD)		
8-1/2ft x 45ft	36		PART NUMBER	SP-HBIIM-N	DRAWN BY PS
8-1/2ft x 53ft	42		DATE	AUGUST 24, 2016	REVISION 1
B-Train 8-1/2ft x 28ft & 32ft	46				
Double Decker Van 8-1/2ft x 48ft	76				



FEATURE	DESCRIPTION	SPECIFICATION
Capacity	Tilt Out Bag Cage	8 cu.ft. 60 US Gallons (225L)
	Poly Bag	2.5 mil 30 x 38 (760 x 965)
Construction	Housing	12 Ga. (2.6) Galvanneal Steel
	Lid	14 Ga. (1.9) Galvanneal Steel
	User Door	14 Ga. (1.9) Galvanneal Steel
	Side Hinged Unloading Door	14 Ga. (1.9) Galvanneal Steel
	Hinges and Latches	Stainless Steel
	Paint	Powder Coat
Weights	Standard Mini Hid-A-Bag II	240lbs (109kg)
	(Optional) Pre-Cast Mounting Pad (HBG-3702)	395lbs (180kg) 30 x 40 x 4 (760 x 1015 x 102)

ALL SPECIFICATIONS SUBJECT TO CHANGE WITHOUT NOTICE

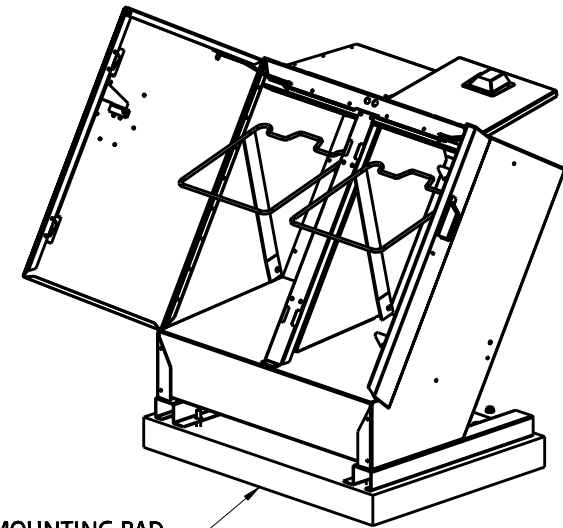

MOUNTING PAD (OPTIONAL)

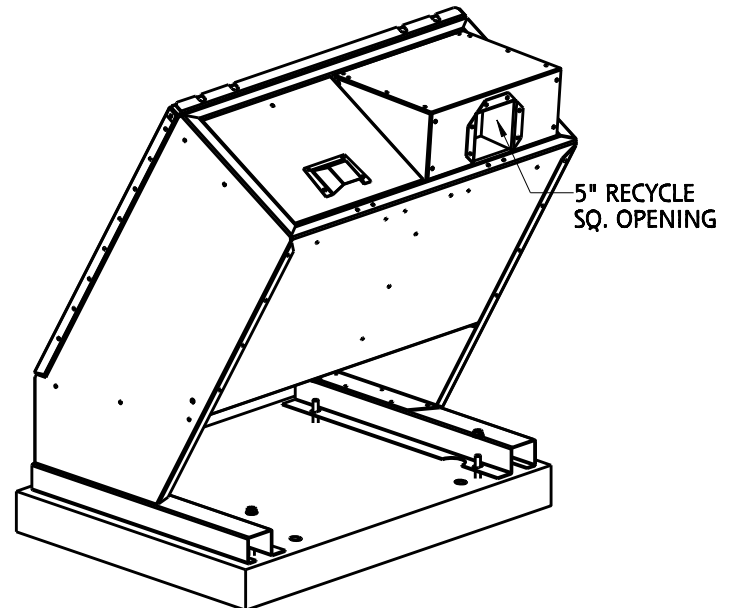

5" RECYCLE SQ. OPENING

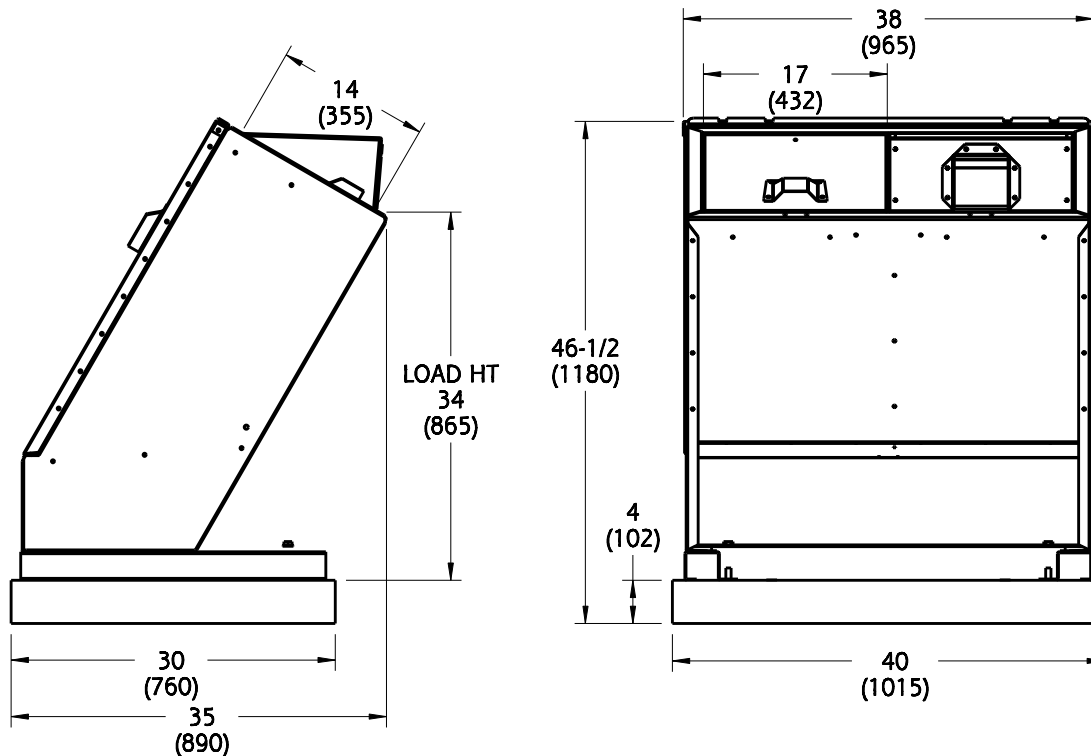

NOTE: ALL DIMENSIONS INCHES (MILLIMETERS)

TRAILER SIZE	QTY	HAUL-ALL EQUIPMENT LTD. reserves proprietary rights on this drawing or any part of the information contained thereon. This drawing shall be considered confidential material and is not to be used for competitive bidding nor for use in any procurements other than from Haul-All Equipment Ltd.	NAME HBIIM WASTE/RECY. CONTAINER			
8-1/2ft x 45ft	36			PART NUMBER	SP-HBIIM-NY	DRAWN BY PS
8-1/2ft x 53ft	42			DATE	AUGUST 23, 2016	REVISION 1
B-Train 8-1/2ft x 28ft & 32ft	46					
Double Decker Van 8-1/2ft x 48ft	76					

FEATURE	DESCRIPTION	SPECIFICATION
Capacity	Tilt Out Bag Cage	8 cu.ft. 60 US Gallons (225L)
	Poly Bag	2.5 mil 30 x 38 (760 x 965)
Construction	Housing	12 Ga. (2.6) Galvanneal Steel
	Lid	14 Ga. (1.9) Galvanneal Steel
	User Door	14 Ga. (1.9) Galvanneal Steel
	Side Hinged Unloading Door	14 Ga. (1.9) Galvanneal Steel
	Hinges and Latches	Stainless Steel
	Paint	Powder Coat
Weights	Standard Mini Hid-A-Bag II	250lbs (114kg)
	(Optional) Pre-Cast Mounting Pad (HBG-3702)	395lbs (180kg) 30 x 40 x 4 (760 x 1015 x 102)

ALL SPECIFICATIONS SUBJECT TO CHANGE WITHOUT NOTICE

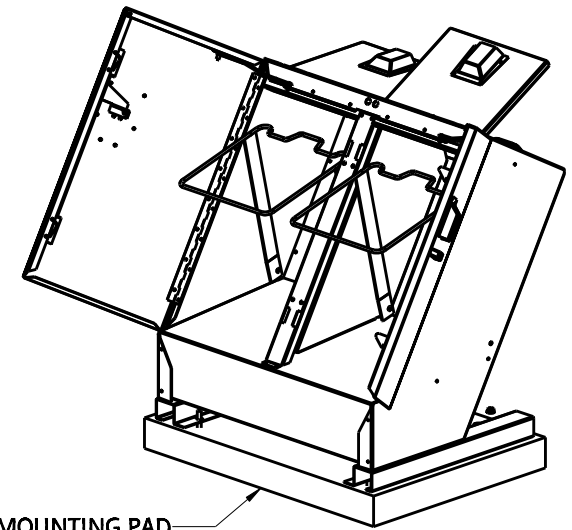

MOUNTING PAD
(OPTIONAL)

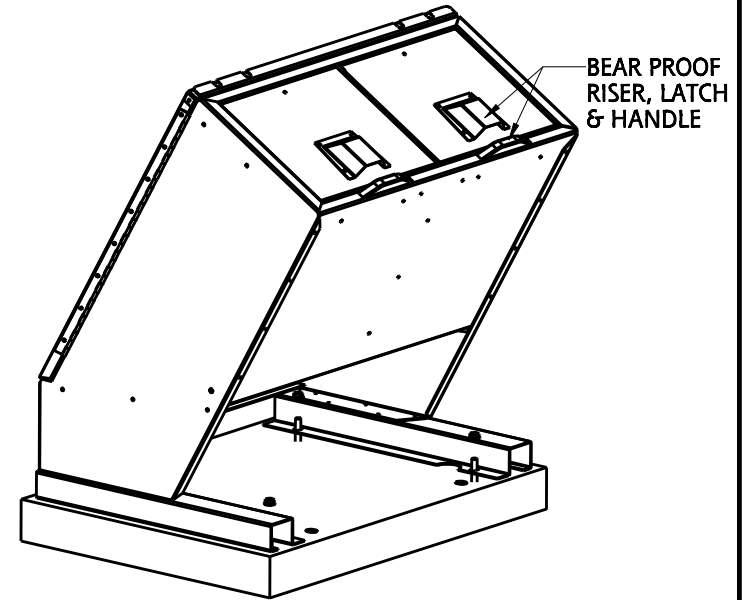

BEAR PROOF
RISER, LATCH
& HANDLE

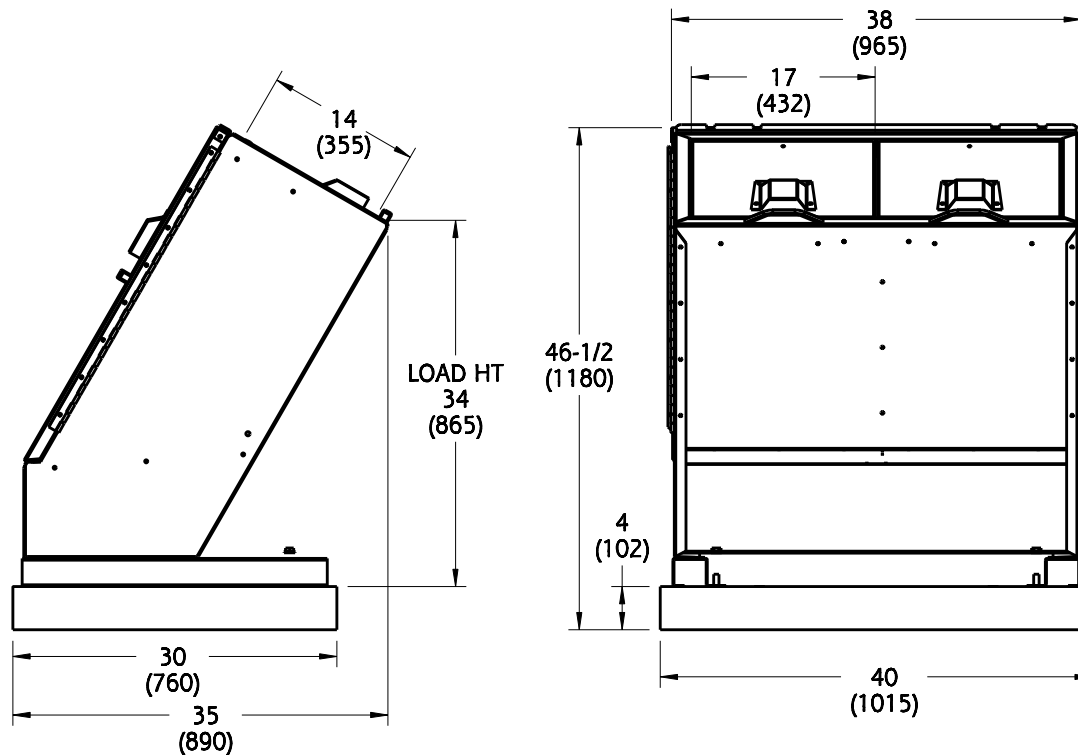

NOTE: ALL DIMENSIONS INCHES (MILLIMETERS)

TRAILER SIZE	QTY	HAUL-ALL EQUIPMENT LTD. reserves proprietary rights on this drawing or any part of the information contained thereon. This drawing shall be considered confidential material and is not to be used for competitive bidding nor for use in any procurements other than from Haul-All Equipment Ltd.	NAME HBIIM BEAR PROOF CONTAINER	
8-1/2ft x 45ft	36		PART NUMBER SP-HBIIM-P	DRAWN BY PS
8-1/2ft x 53ft	42		DATE AUGUST 23, 2016	REVISION 1
B-Train 8-1/2ft x 28ft & 32ft	46			
Double Decker Van 8-1/2ft x 48ft	76			



FEATURE	DESCRIPTION	SPECIFICATION
Capacity	Tilt Out Bag Cage	8 cu.ft. 60 US Gallons (225L)
	Poly Bag	2.5 mil 30 x 38 (760 x 965)
Construction	Housing	12 Ga. (2.6) Galvanneal Steel
	Lid	14 Ga. (1.9) Galvanneal Steel
	User Door	14 Ga. (1.9) Galvanneal Steel
	Side Hinged Unloading Door	14 Ga. (1.9) Galvanneal Steel
	Hinges and Latches	Stainless Steel
	Paint	Powder Coat
Weights	Standard Mini Hid-A-Bag II	240lbs (109kg)
	(Optional) Pre-Cast Mounting Pad (HBG-3702)	395lbs (180kg) 30 x 40 x 4 (760 x 1015 x 102)

ALL SPECIFICATIONS SUBJECT TO CHANGE WITHOUT NOTICE

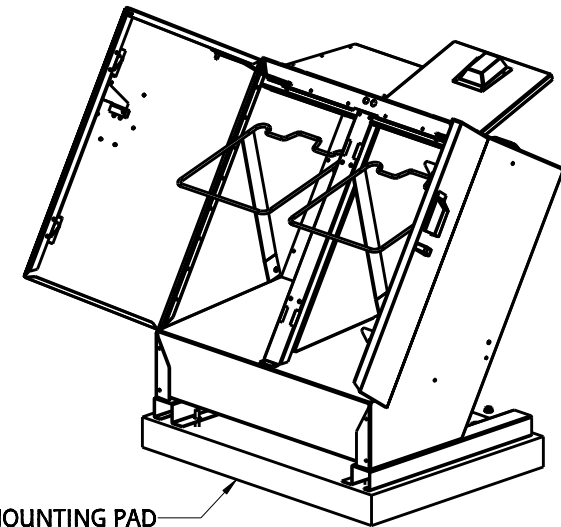

MOUNTING PAD (OPTIONAL)

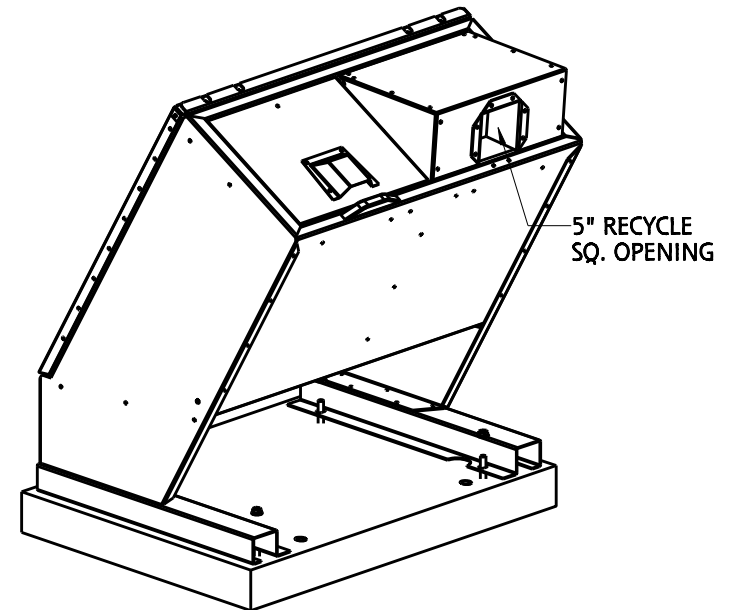

5" RECYCLE SQ. OPENING

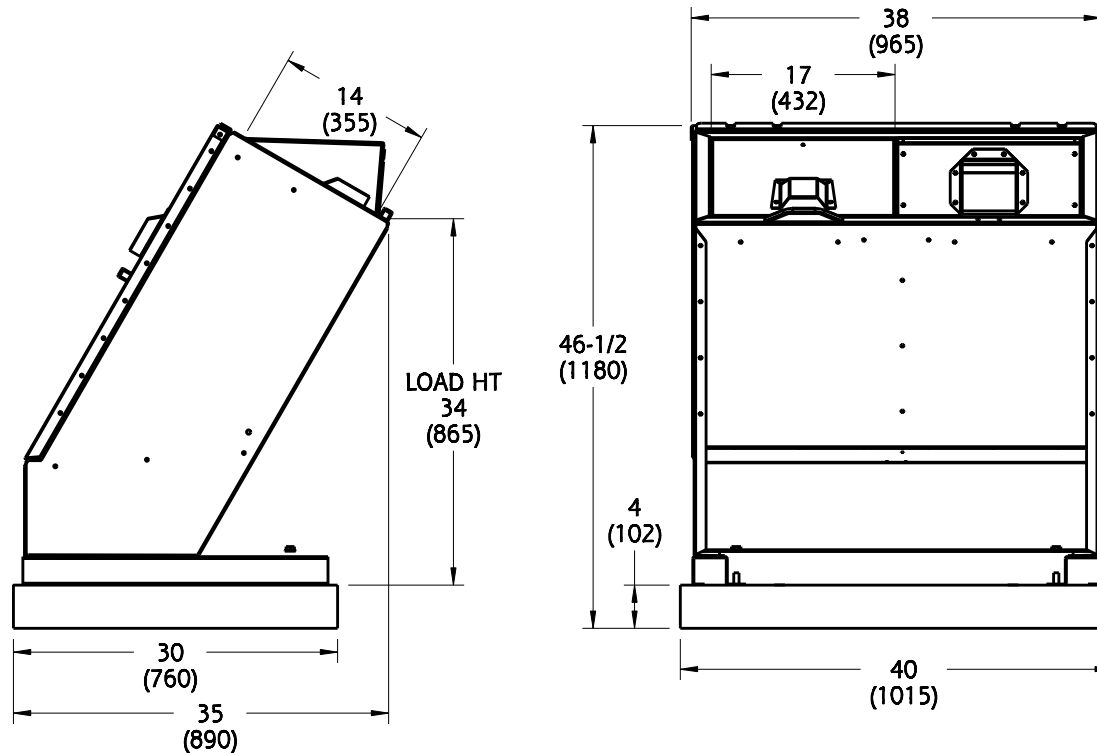

NOTE: ALL DIMENSIONS INCHES (MILLIMETERS)

TRAILER SIZE	QTY	HAUL-ALL EQUIPMENT LTD. reserves proprietary rights on this drawing or any part of the information contained thereon. This drawing shall be considered confidential material and is not to be used for competitive bidding nor for use in any procurements other than from Haul-All Equipment Ltd.	NAME HBIIM WASTE/RECY. BP CONTAINER		
8-1/2ft x 45ft	36		PART NUMBER	SP-HBIIM-PY	DRAWN BY PS
8-1/2ft x 53ft	42		DATE	AUGUST 23, 2016	REVISION 1
B-Train 8-1/2ft x 28ft & 32ft	46				
Double Decker Van 8-1/2ft x 48ft	76				



FEATURE	DESCRIPTION	SPECIFICATION
Capacity	Tilt Out Bag Cage	8 cu.ft. 60 US Gallons (225L)
	Poly Bag	2.5 mil 30 x 38 (760 x 965)
Construction	Housing	12 Ga. (2.6) Galvanneal Steel
	Lid	14 Ga. (1.9) Galvanneal Steel
	User Door	14 Ga. (1.9) Galvanneal Steel
	Side Hinged Unloading Door	14 Ga. (1.9) Galvanneal Steel
	Hinges and Latches	Stainless Steel
	Paint	Powder Coat
Weights	Standard Mini Hid-A-Bag II	240lbs (110kg)
	(Optional) Pre-Cast Mounting Pad (HBG-3702)	395lbs (180kg) 30 x 40 x 4 (760 x 1015 x 102)

ALL SPECIFICATIONS SUBJECT TO CHANGE WITHOUT NOTICE

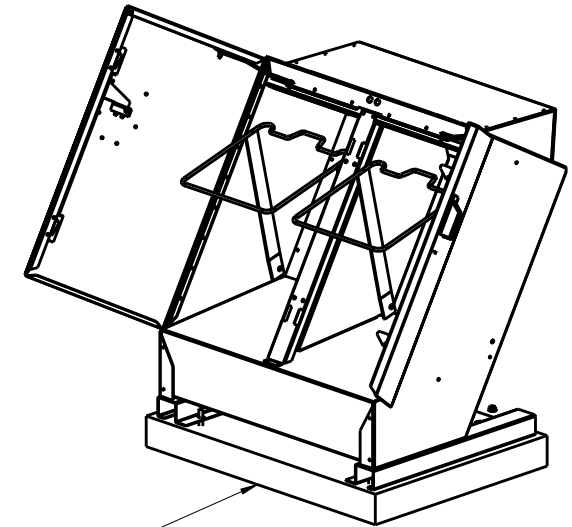

MOUNTING PAD (OPTIONAL)

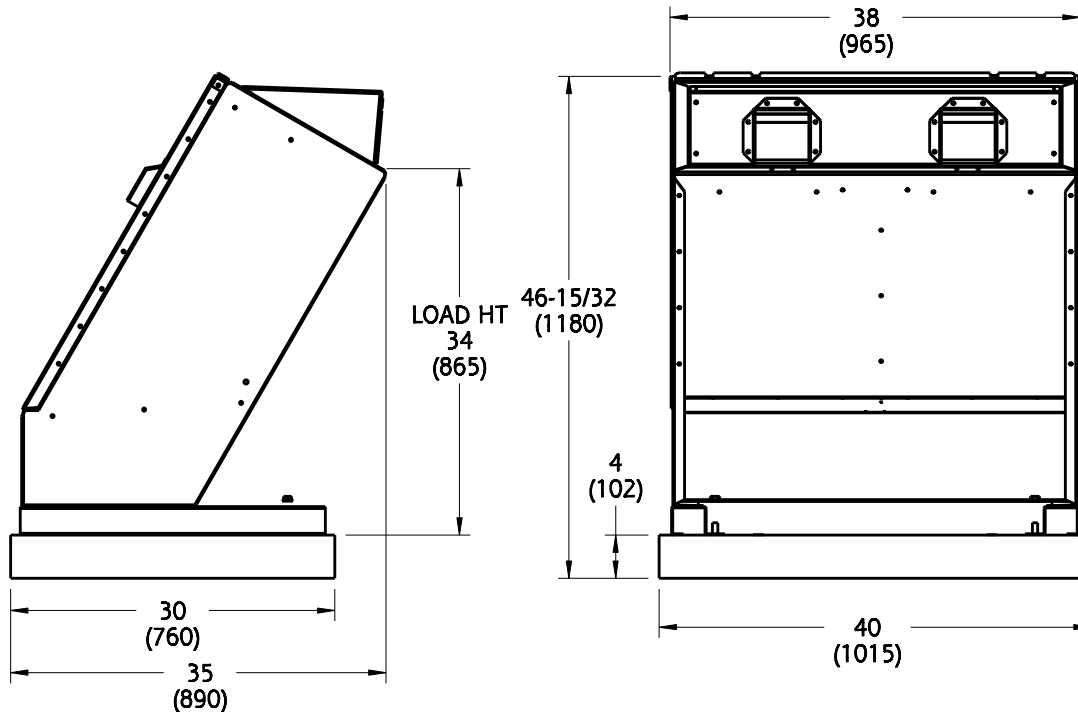
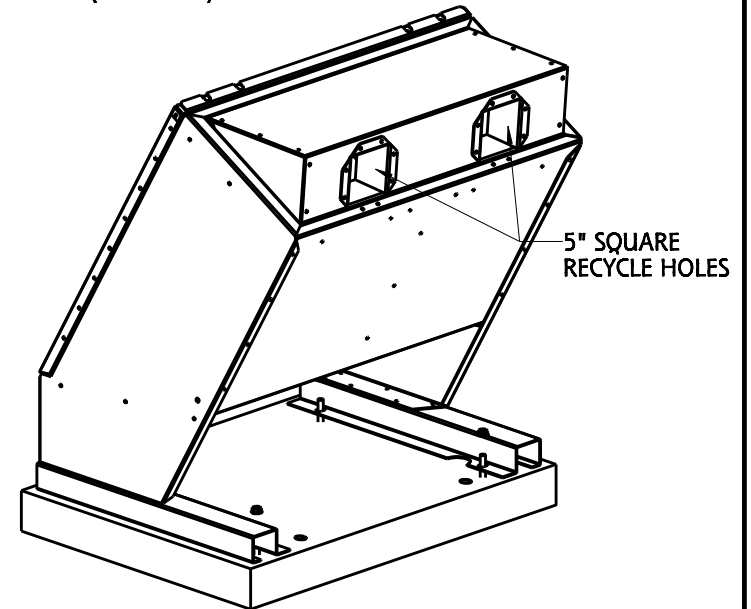

NOTE: ALL DIMENSIONS INCHES (MILLIMETERS)

TRAILER SIZE	QTY	HAUL-ALL EQUIPMENT LTD. reserves proprietary rights on this drawing or any part of the information contained thereon. This drawing shall be considered confidential material and is not to be used for competitive bidding nor for use in any procurements other than from Haul-All Equipment Ltd.	NAME HBIIM SQ. RECYCLE CONTAINER	
8-1/2ft x 45ft	36		PART NUMBER SP-HBIIM-Y	DRAWN BY PS
8-1/2ft x 53ft	42		DATE AUGUST 22, 2016	REVISION 1
B-Train 8-1/2ft x 28ft & 32ft	46			
Double Decker Van 8-1/2ft x 48ft	76			



FEATURE	DESCRIPTION	SPECIFICATION
Capacity	Tilt Out Bag Cage	8 cu.ft. 60 US Gallons (225L)
	Poly Bag	2.5 mil 30 x 38 (760 x 965)
Construction	Housing	12 Ga. (2.6) Galvanneal Steel
	Lid	14 Ga. (1.9) Galvanneal Steel
	User Door	14 Ga. (1.9) Galvanneal Steel
	Side Hinged Unloading Door	14 Ga. (1.9) Galvanneal Steel
	Hinges and Latches	Stainless Steel
	Paint	Powder Coat
Weights	Standard Mini Hid-A-Bag II	240lbs (109kg)
	(Optional) Pre-Cast Mounting Pad (HBG-3702)	395lbs (180kg) 30 x 40 x 4 (760 x 1015 x 102)

ALL SPECIFICATIONS SUBJECT TO CHANGE WITHOUT NOTICE

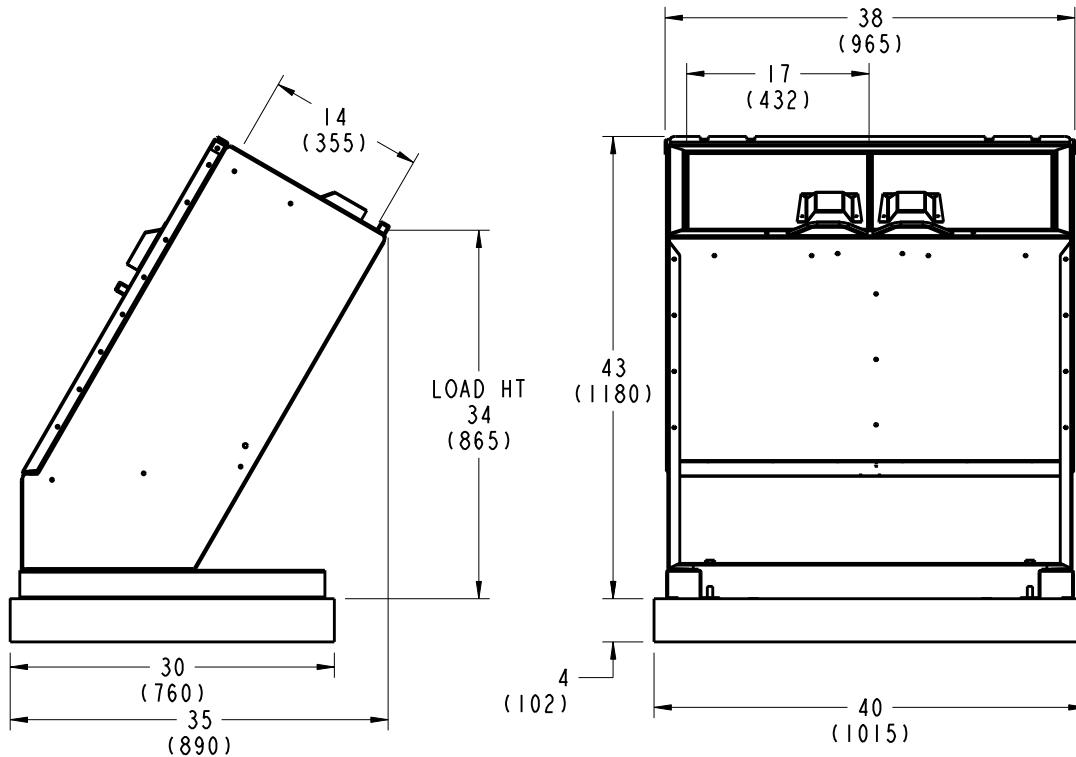
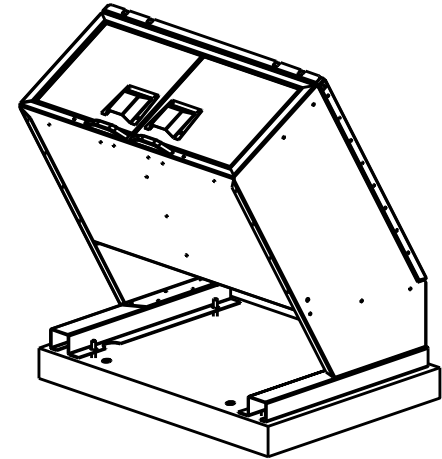
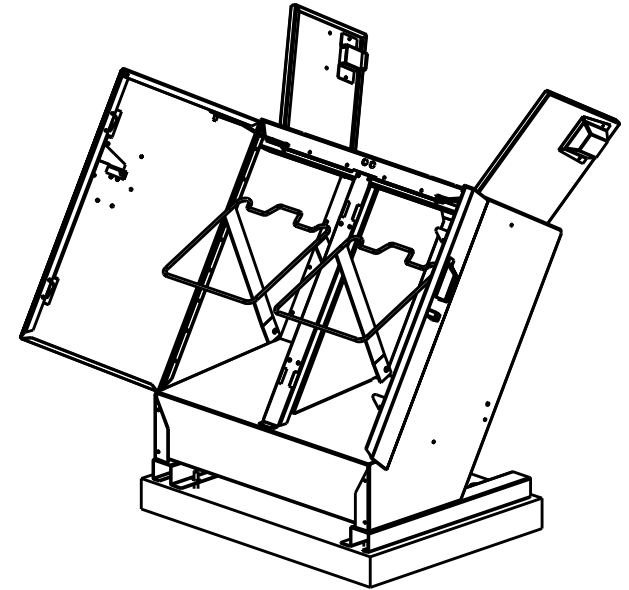

NOTE: ALL DIMENSIONS INCHES (MILLIMETERS)

TRAILER SIZE	QTY
8-1/2ft x 45ft	36
8-1/2ft x 53ft	42
B-Train 8-1/2ft x 28ft & 32ft	46
Double Decker Van 8-1/2ft x 48ft	76

HAUL-ALL EQUIPMENT LTD. reserves proprietary rights on this drawing or any part of the information contained thereon. This drawing shall be considered confidential material and is not to be used for competitive bidding nor for use in any procurements other than from Haul-All Equipment Ltd.



NAME HBIIA BP SIDE LOAD DOOR CONT.		
PART NUMBER	SP-HBIIA-P	DRAWN BY PS
DATE	AUGUST 25, 2016	REVISION 1