

FEATURE	DESCRIPTION	SPECIFICATION
Capacity	Tilt Out Bag Cage	17-1/2 cu.ft. 130 US Gallons (500L)
	2-Poly Bags	2.5 mil 42 x 50 (1070 x 1270)
Construction	Housing	12 Ga. (2.6) Galvanneal Steel
	Lid	14 Ga. (1.9) Galvanneal Steel
	User Door	14 Ga. (1.9) Galvanneal Steel
	Side Hinged Unloading Door	14 Ga. (1.9) Galvanneal Steel
	Hinges and Latches	Stainless Steel
	Paint	Powder Coat
Weights	Standard Hid-A-Bag II	325lbs (150kg)
	(Optional) Pre-Cast Mounting Pad (HBII-572)	595lbs (270kg) 48 x 36 x 4 (1220 x 915 x 102)

ALL SPECIFICATIONS SUBJECT TO CHANGE WITHOUT NOTICE

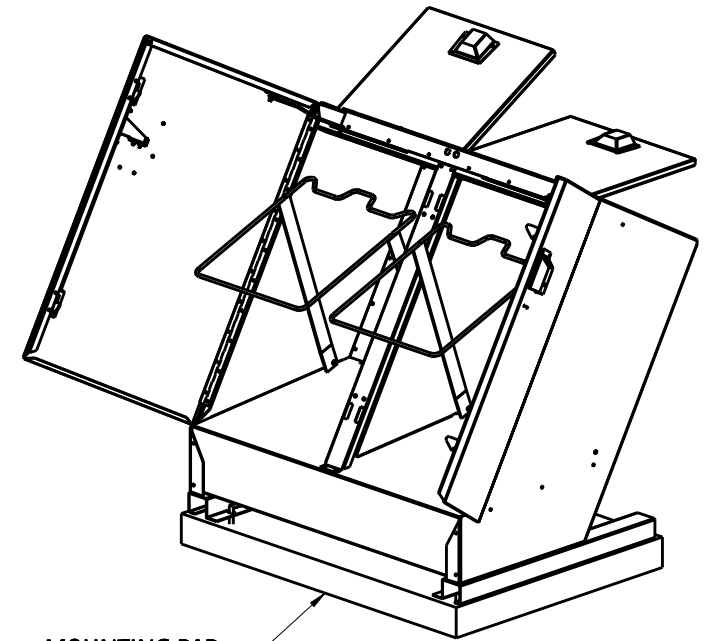

MOUNTING PAD
(OPTIONAL)

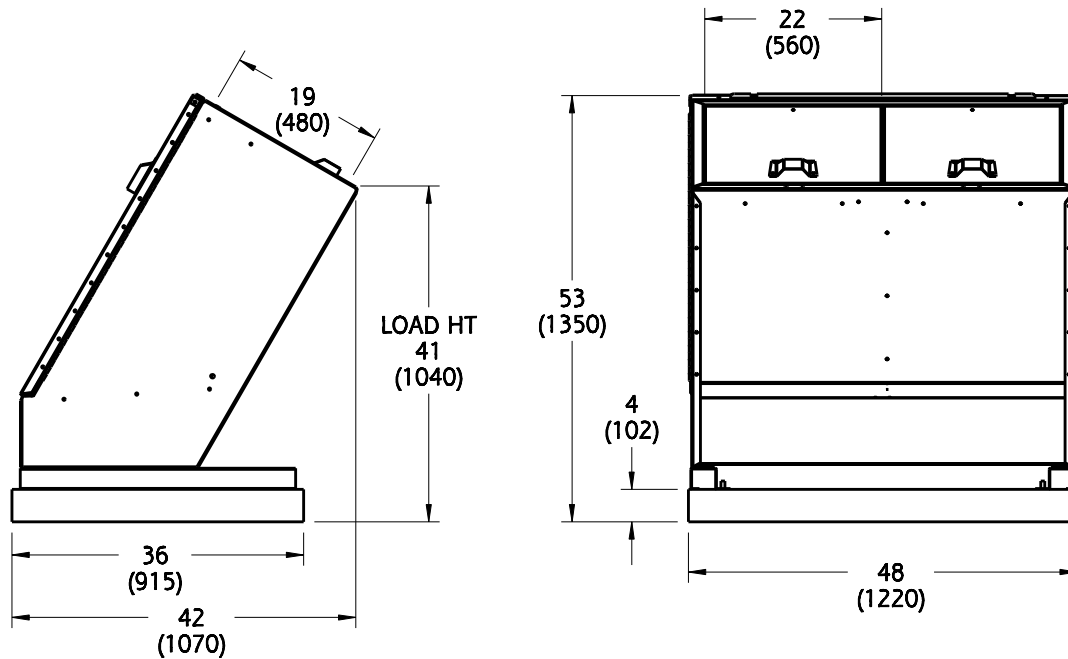
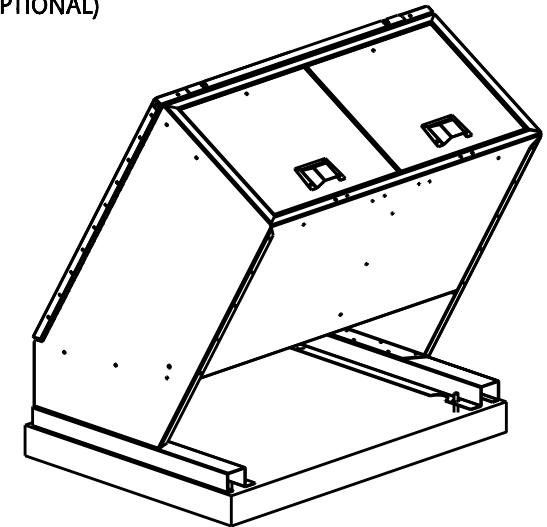

NOTE: ALL DIMENSIONS INCHES (MILLIMETERS)

TRAILER SIZE	QTY	<p>HAUL-ALL EQUIPMENT LTD. reserves proprietary rights on this drawing or any part of the information contained thereon. This drawing shall be considered confidential material and is not to be used for competitive bidding nor for use in any procurements other than from Haul-All Equipment Ltd.</p> 	NAME HBIIS STANDARD CONTAINER	
8-1/2ft x 45ft	30		PART NUMBER SP-HBIIS-N	DRAWN BY PS
8-1/2ft x 53ft	36		DATE AUGUST 17, 2016	REVISION 1
B-Train 8-1/2ft x 28ft & 32ft	36			
Double Decker Van 8-1/2ft x 48ft	64			

FEATURE	DESCRIPTION	SPECIFICATION
Capacity	Tilt Out Bag Cage	17-1/2 cu.ft. 130 US Gallons (500L)
	2-Poly Bags	2.5 mil 42 x 50 (1070 x 1270)
Construction	Housing	12 Ga. (2.6) Galvanneal Steel
	Lid	14 Ga. (1.9) Galvanneal Steel
	User Door	14 Ga. (1.9) Galvanneal Steel
	Side Hinged Unloading Door	14 Ga. (1.9) Galvanneal Steel
	Hinges and Latches	Stainless Steel
	Paint	Powder Coat
Weights	Standard Hid-A-Bag II	325lbs (150kg)
(Optional)	Pre-Cast Mounting Pad (HBII-572)	595lbs (270kg) 48 x 36 x 4 (1220 x 915 x 102)

ALL SPECIFICATIONS SUBJECT TO CHANGE WITHOUT NOTICE

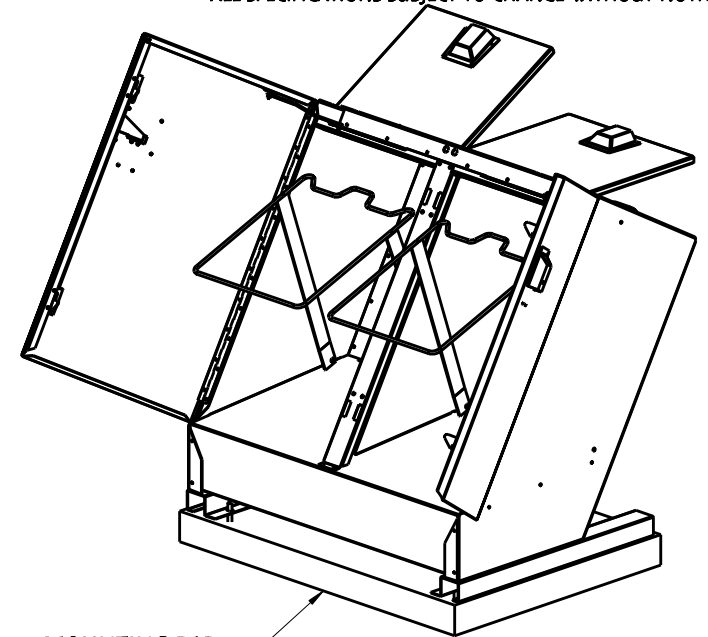

MOUNTING PAD
(OPTIONAL)

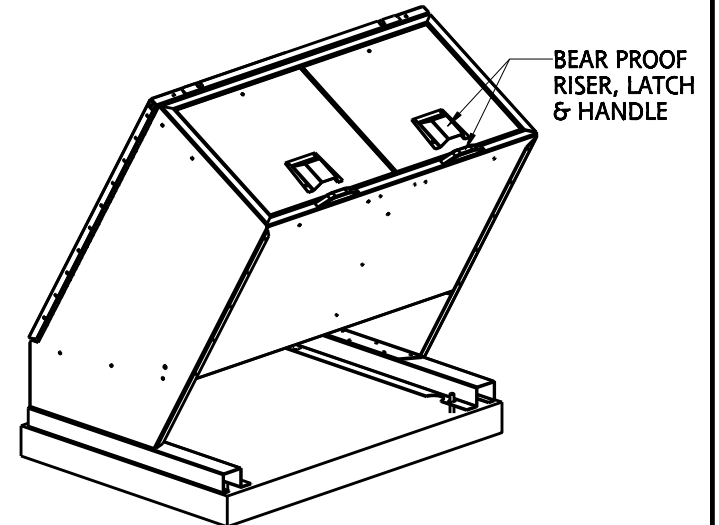

BEAR PROOF
RISER, LATCH
& HANDLE

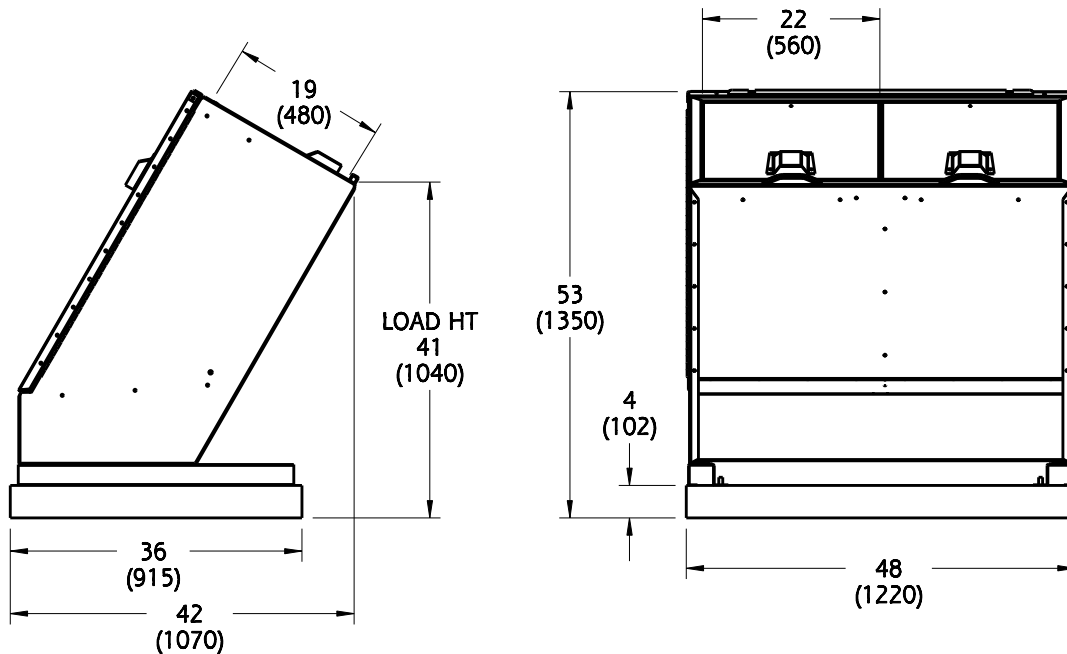

NOTE: ALL DIMENSIONS INCHES (MILLIMETERS)

TRAILER SIZE	QTY	<p>HAUL-ALL EQUIPMENT LTD. reserves proprietary rights on this drawing or any part of the information contained thereon. This drawing shall be considered confidential material and is not to be used for competitive bidding nor for use in any procurements other than from Haul-All Equipment Ltd.</p> 	NAME HBIIS STANDARD BP CONTAINER		
8-1/2ft x 45ft Long	30		PART NUMBER SP-HBIIS-P	DRAWN BY PS	
8-1/2ft x 53ft Long	36		DATE AUGUST 17, 2016	REVISION 1	
B-Train	36				
Double Decker Van 8-1/2ft x 48ft	64				

FEATURE	DESCRIPTION	SPECIFICATION
Capacity	Tilt Out Bag Cage	17-1/2 cu.ft. 130 US Gallons (500L)
	2-Poly Bags	2.5 mil 42 x 50 (1070 x 1270)
Construction	Housing	12 Ga. (2.6) Galvanneal Steel
	Lid	14 Ga. (1.9) Galvanneal Steel
	User Door	14 Ga. (1.9) Galvanneal Steel
	Side Hinged Unloading Door	14 Ga. (1.9) Galvanneal Steel
	Hinges and Latches	Stainless Steel
	Paint	Powder Coat
Weights	Standard Hid-A-Bag II	325lbs (150kg)
(Optional)	Pre-Cast Mounting Pad (HBII-572)	595lbs (270kg) 48 x 36 x 4 (1220 x 915 x 102)

ALL SPECIFICATIONS SUBJECT TO CHANGE WITHOUT NOTICE

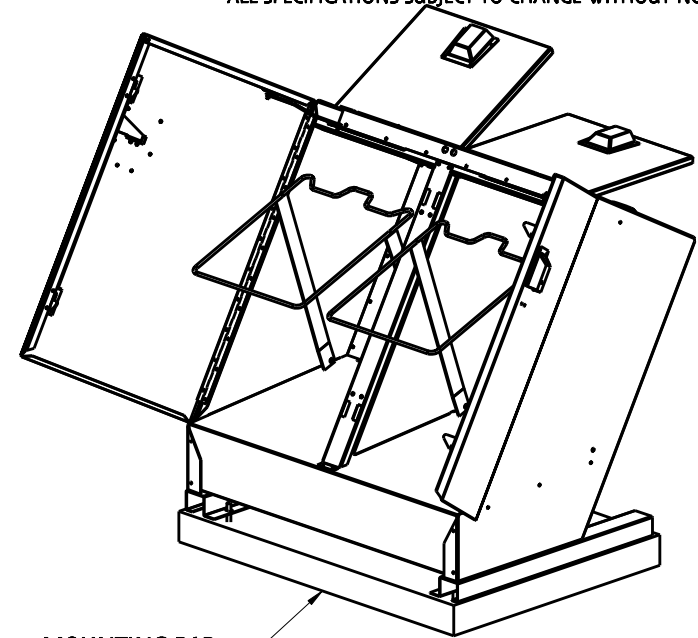

MOUNTING PAD (OPTIONAL)

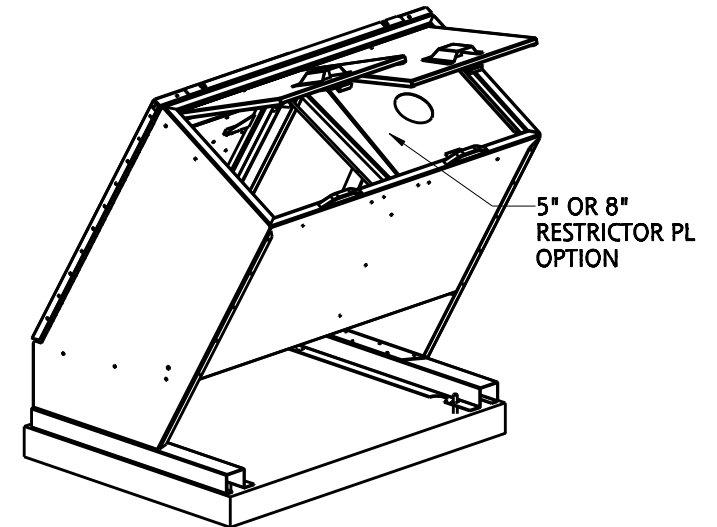

5" OR 8" RESTRICTOR PL OPTION

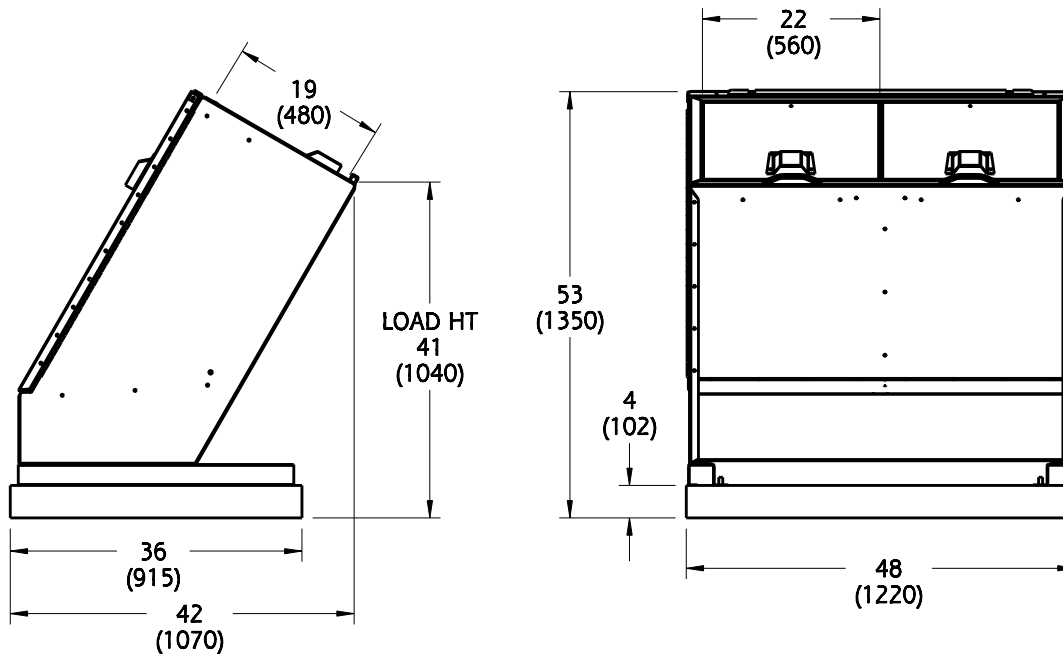

NOTE: ALL DIMENSIONS INCHES (MILLIMETERS)

TRAILER SIZE	QTY
8-1/2ft x 45ft Long	30
8-1/2ft x 53ft Long	36
B-Train	36
Double Decker Van 8-1/2ft x 48ft	64

HAUL-ALL EQUIPMENT LTD. reserves proprietary rights on this drawing or any part of the information contained thereon. This drawing shall be considered confidential material and is not to be used for competitive bidding nor for use in any procurements other than from Haul-All Equipment Ltd.



NAME	
HBIIS WASTE/RESTRICT BP CONTAINER	
PART NUMBER	SP-HBIIS-PR
DATE	AUGUST 17, 2016
DRAWN BY	PS
REVISION	1

FEATURE	DESCRIPTION	SPECIFICATION
Capacity	Tilt Out Bag Cage	17-1/2 cu.ft. 130 US Gallons (500L)
	2-Poly Bags	2.5 mil 42 x 50 (1070 x 1270)
Construction	Housing	12 Ga. (2.6) Galvanneal Steel
	Lid	14 Ga. (1.9) Galvanneal Steel
	User Door	14 Ga. (1.9) Galvanneal Steel
	Side Hinged Unloading Door	14 Ga. (1.9) Galvanneal Steel
	Hinges and Latches	Stainless Steel
	Paint	Powder Coat
Weights	Standard Hid-A-Bag II	325lbs (150kg)
(Optional)	Pre-Cast Mounting Pad (HBII-572)	595lbs (270kg) 48 x 36 x 4 (1220 x 915 x 102)

ALL SPECIFICATIONS SUBJECT TO CHANGE WITHOUT NOTICE

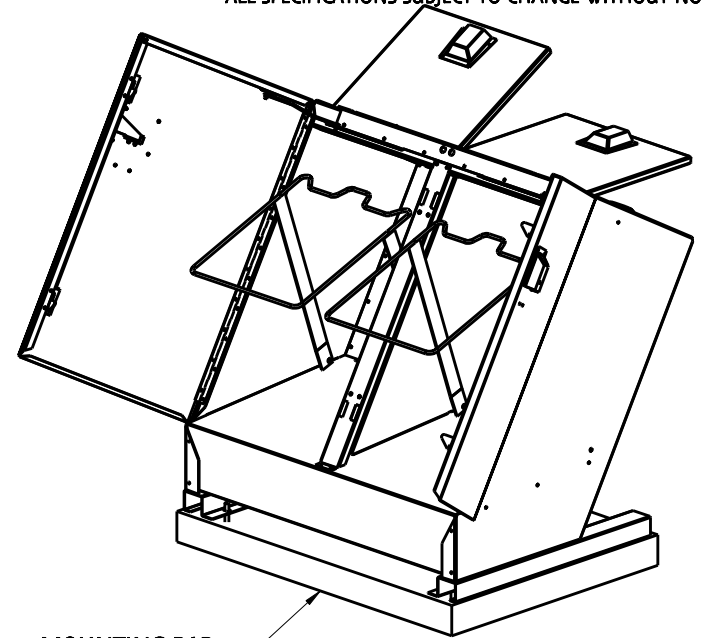

MOUNTING PAD
(OPTIONAL)

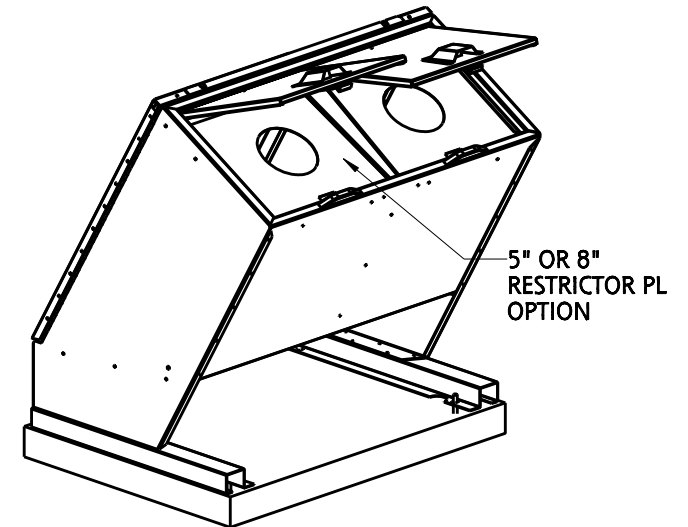

5" OR 8"
RESTRICTOR PL
OPTION

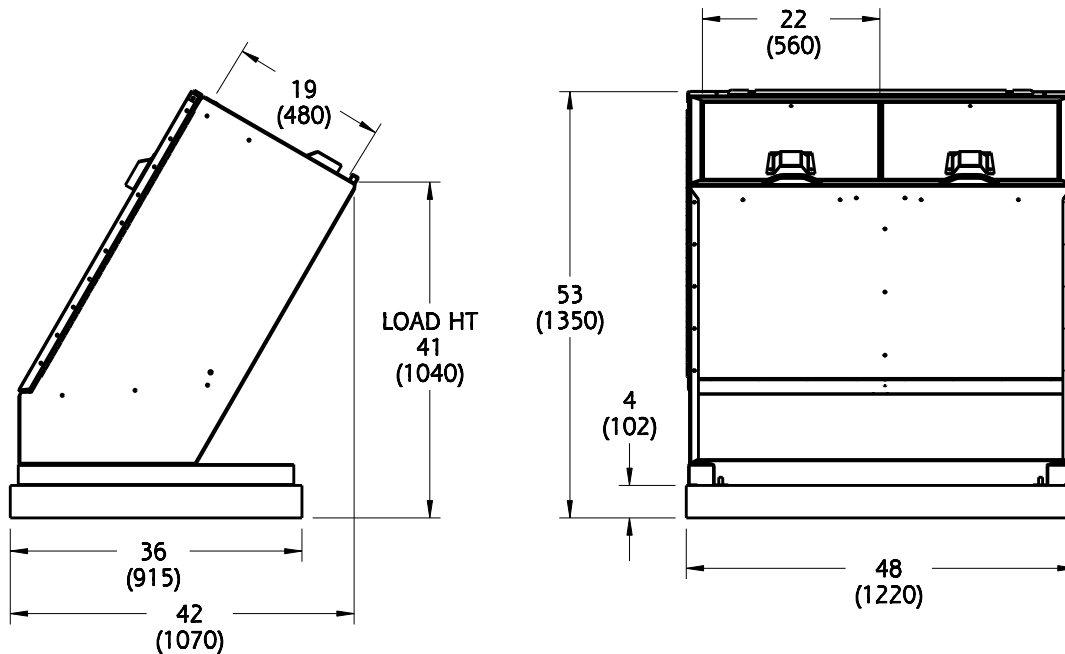

NOTE: ALL DIMENSIONS INCHES (MILLIMETERS)

TRAILER SIZE	QTY	<p>HAUL-ALL EQUIPMENT LTD. reserves proprietary rights on this drawing or any part of the information contained thereon. This drawing shall be considered confidential material and is not to be used for competitive bidding nor for use in any procurements other than from Haul-All Equipment Ltd.</p> 	NAME HBIIIS RESTRICTOR PL BP CONTAINER	
8-1/2ft x 45ft Long	30		PART NUMBER SP-HBIIS-PRB	DRAWN BY PS
8-1/2ft x 53ft Long	36		DATE AUGUST 17, 2016	REVISION 1
B-Train	36			
Double Decker Van 8-1/2ft x 48ft	64			

FEATURE	DESCRIPTION	SPECIFICATION
Capacity	Tilt Out Bag Cage 2-Poly Bags	17-1/2 cu.ft. 130 US Gallons (500L) 2.5 mil 42 x 50 (1070 x 1270)
Construction	Housing	12 Ga. (2.6) Galvanneal Steel
	Lid	14 Ga. (1.9) Galvanneal Steel
	User Door	14 Ga. (1.9) Galvanneal Steel
	Side Hinged Unloading Door	14 Ga. (1.9) Galvanneal Steel
	Hinges and Latches	Stainless Steel
	Paint	Powder Coat
Weights	Standard Hid-A-Bag II	325lbs (150kg)
(Optional)	Pre-Cast Mounting Pad (HBII-572)	595lbs (270kg) 48 x 36 x 4 (1220 x 915 x 102)

ALL SPECIFICATIONS SUBJECT TO CHANGE WITHOUT NOTICE

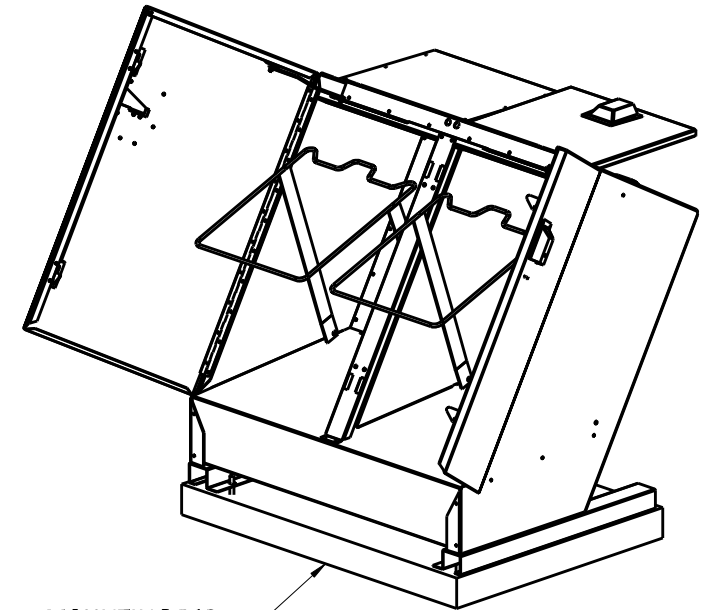

MOUNTING PAD (OPTIONAL)

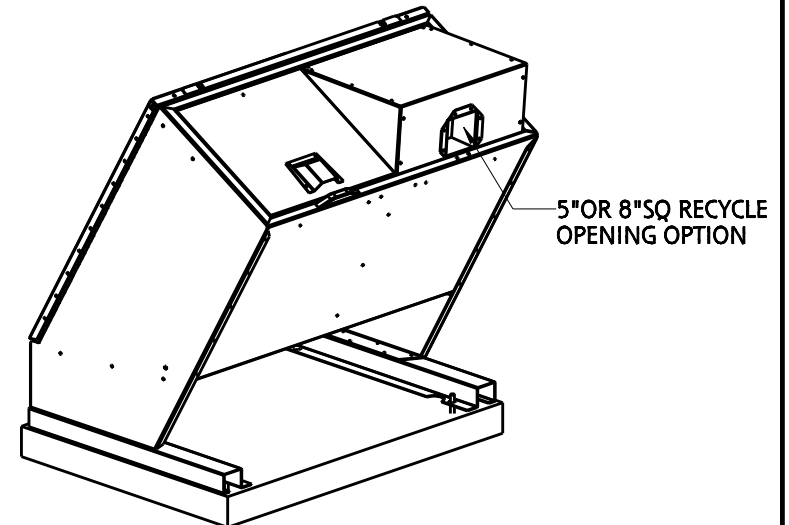

5" OR 8" SQ RECYCLE OPENING OPTION

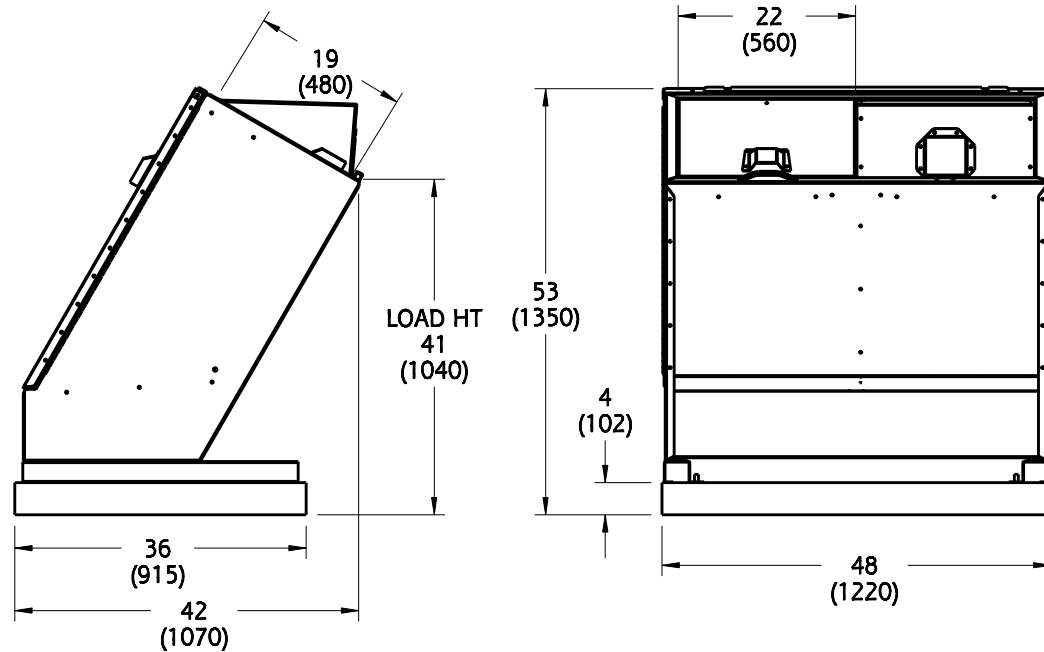

NOTE: ALL DIMENSIONS INCHES (MILLIMETERS)

TRAILER SIZE	QTY
8-1/2ft x 45ft Long	30
8-1/2ft x 53ft Long	36
B-Train	36
Double Decker Van 8-1/2ft x 48ft	64

HAUL-ALL EQUIPMENT LTD. reserves proprietary rights on this drawing or any part of the information contained thereon. This drawing shall be considered confidential material and is not to be used for competitive bidding nor for use in any procurements other than from Haul-All Equipment Ltd.



NAME HBIIS WASTE/RECY. BP CONTAINER	
PART NUMBER SP-HBIIS-PY	DRAWN BY PS
DATE AUGUST 17, 2016	REVISION 1

FEATURE	DESCRIPTION	SPECIFICATION
Capacity	Tilt Out Bag Cage	17-1/2 cu.ft. 130 US Gallons (500L)
	2-Poly Bags	2.5 mil 42 x 50 (1070 x 1270)
Construction	Housing	12 Ga. (2.6) Galvanneal Steel
	Lid	14 Ga. (1.9) Galvanneal Steel
	User Door	14 Ga. (1.9) Galvanneal Steel
	Side Hinged Unloading Door	14 Ga. (1.9) Galvanneal Steel
	Hinges and Latches	Stainless Steel
	Paint	Powder Coat
Weights	Standard Hid-A-Bag II	325lbs (150kg)
(Optional)	Pre-Cast Mounting Pad (HBII-572)	595lbs (270kg) 48 x 36 x 4 (1220 x 915 x 102)

ALL SPECIFICATIONS SUBJECT TO CHANGE WITHOUT NOTICE

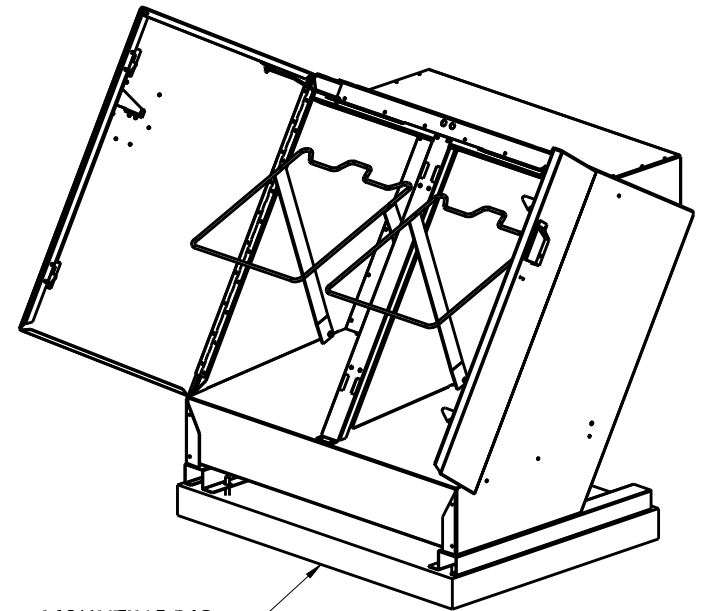

MOUNTING PAD
(OPTIONAL)

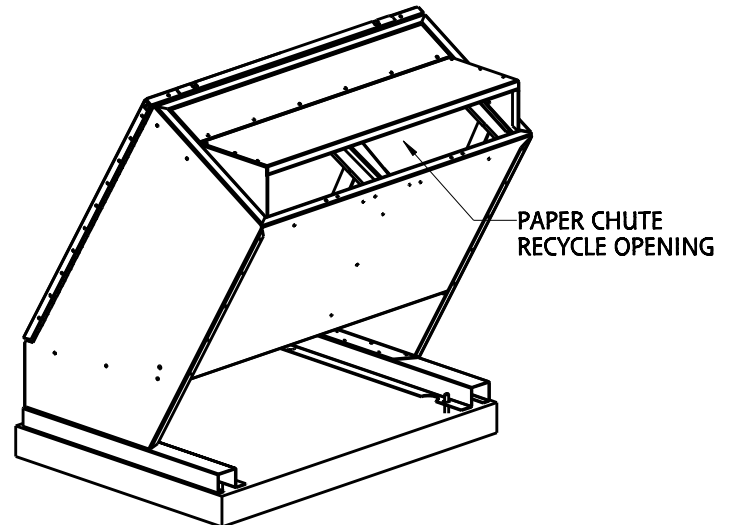

PAPER CHUTE
RECYCLE OPENING

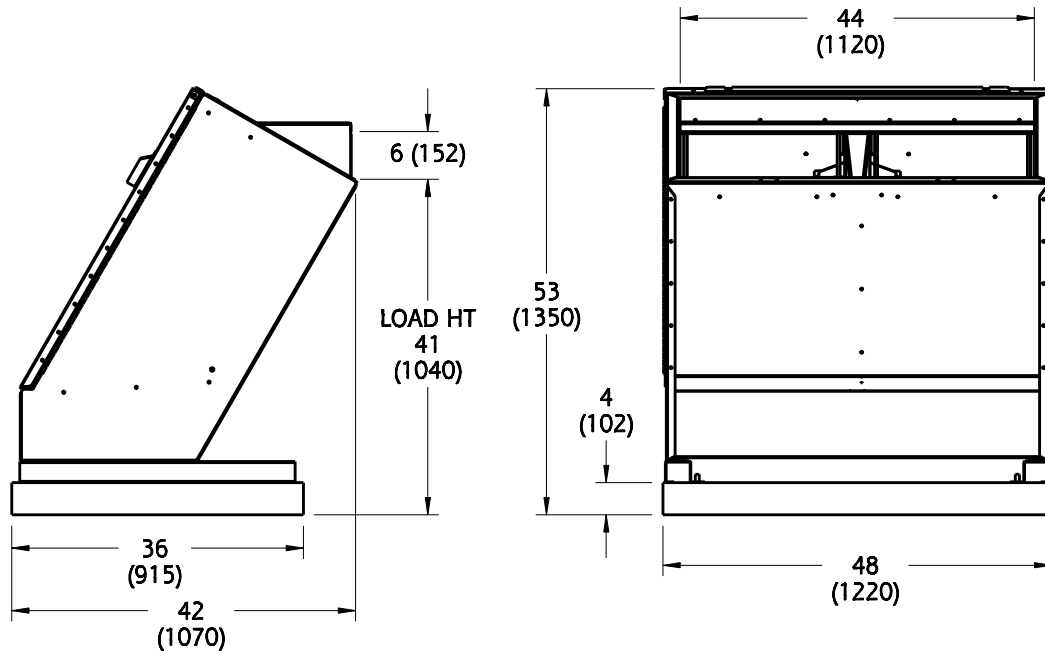

NOTE: ALL DIMENSIONS INCHES (MILLIMETERS)

TRAILER SIZE	QTY
8-1/2ft x 45ft Long	30
8-1/2ft x 53ft Long	36
B-Train	36
Double Decker Van 8-1/2ft x 48ft	64

HAUL-ALL EQUIPMENT LTD. reserves proprietary rights on this drawing or any part of the information contained thereon. This drawing shall be considered confidential material and is not to be used for competitive bidding nor for use in any procurements other than from Haul-All Equipment Ltd.



NAME HBIIS PAPER RECYCLER CONTAINER		
PART NUMBER	SP-HBIIS-U	DRAWN BY PS
DATE	AUGUST 17, 2016	REVISION 1

FEATURE	DESCRIPTION	SPECIFICATION
Capacity	Tilt Out Bag Cage 2-Poly Bags	17-1/2 cu.ft. 130 US Gallons (500L) 2.5 mil 42 x 50 (1070 x 1270)
Construction	Housing	12 Ga. (2.6) Galvanneal Steel
	Lid	14 Ga. (1.9) Galvanneal Steel
	User Door	14 Ga. (1.9) Galvanneal Steel
	Side Hinged Unloading Door	14 Ga. (1.9) Galvanneal Steel
	Hinges and Latches	Stainless Steel
	Paint	Powder Coat
Weights	Standard Hid-A-Bag II	325lbs (150kg)
(Optional)	Pre-Cast Mounting Pad (HBII-572)	595lbs (270kg) 48 x 36 x 4 (1220 x 915 x 102)

ALL SPECIFICATIONS SUBJECT TO CHANGE WITHOUT NOTICE

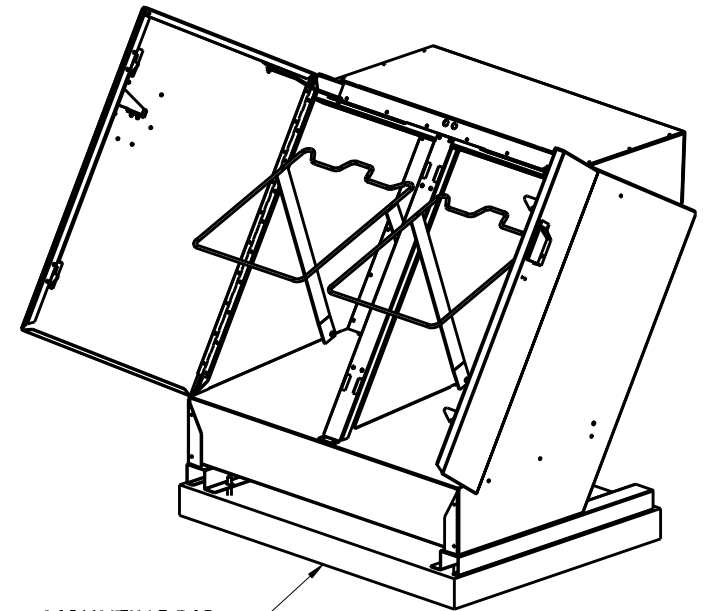

MOUNTING PAD
(OPTIONAL)

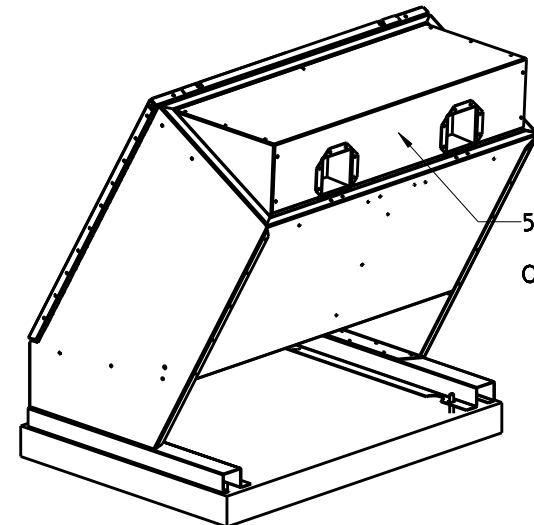

5",8" OR 10"
RECYCLE
OPENING OPTIONS

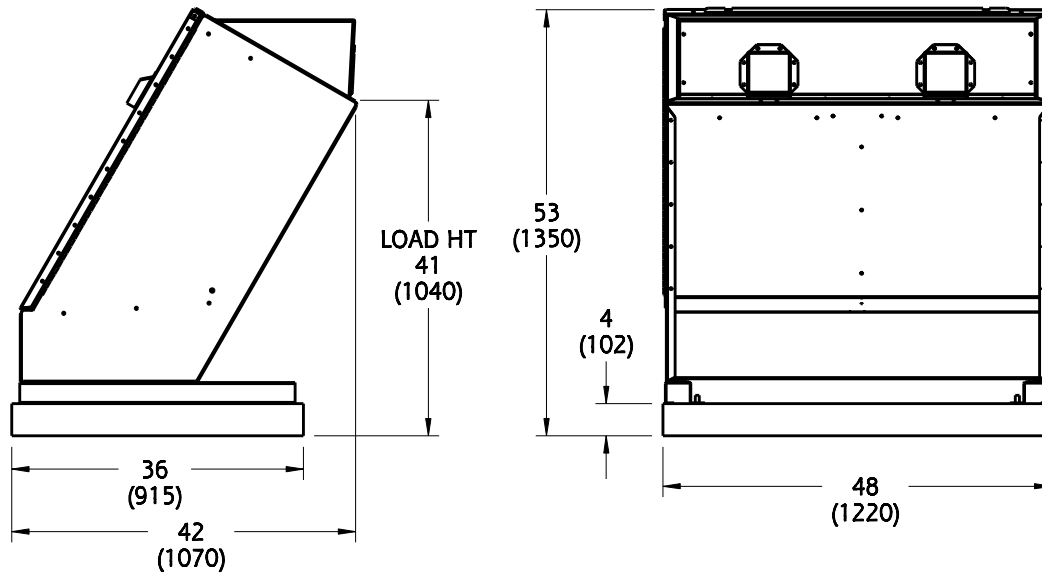

NOTE: ALL DIMENSIONS INCHES (MILLIMETERS)

TRAILER SIZE	QTY
8-1/2ft x 45ft Long	30
8-1/2ft x 53ft Long	36
B-Train	36
Double Decker Van 8-1/2ft x 48ft	64

HAUL-ALL EQUIPMENT LTD. reserves proprietary rights on this drawing or any part of the information contained thereon. This drawing shall be considered confidential material and is not to be used for competitive bidding nor for use in any procurements other than from Haul-All Equipment Ltd.



NAME HBIIS RECYCLING CONTAINER	
PART NUMBER SP-HBIIS-Y	DRAWN BY PS
DATE AUGUST 17, 2016	REVISION 1

FEATURE	DESCRIPTION	SPECIFICATION
Capacity	Tilt Out Bag Cage 2-Poly Bags	17-1/2 cu.ft. 130 US Gallons (500L) 2.5 mil 42 x 50 (1070 x 1270)
Construction	Housing	12 Ga. (2.6) Galvanneal Steel
	Lid	14 Ga. (1.9) Galvanneal Steel
	User Door	14 Ga. (1.9) Galvanneal Steel
	Side Hinged Unloading Door	14 Ga. (1.9) Galvanneal Steel
	Hinges and Latches	Stainless Steel
	Paint	Powder Coat
Weights	Standard Hid-A-Bag II	325lbs (150kg)
(Optional)	Pre-Cast Mounting Pad (HBII-572)	595lbs (270kg) 48 x 36 x 4 (1220 x 915 x 102)

ALL SPECIFICATIONS SUBJECT TO CHANGE WITHOUT NOTICE

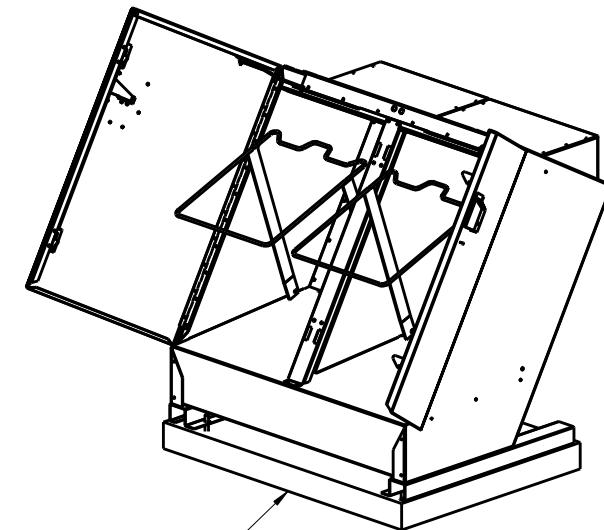

MOUNTING PAD
(OPTIONAL)

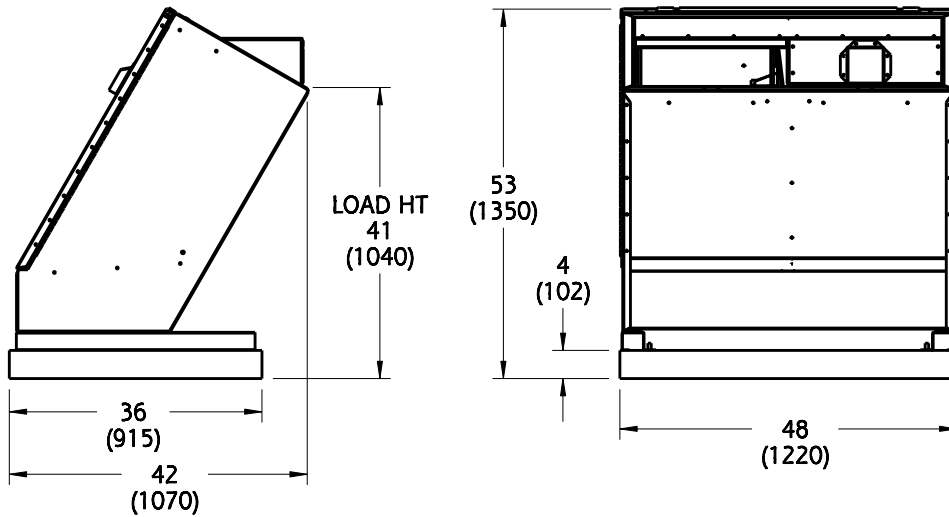
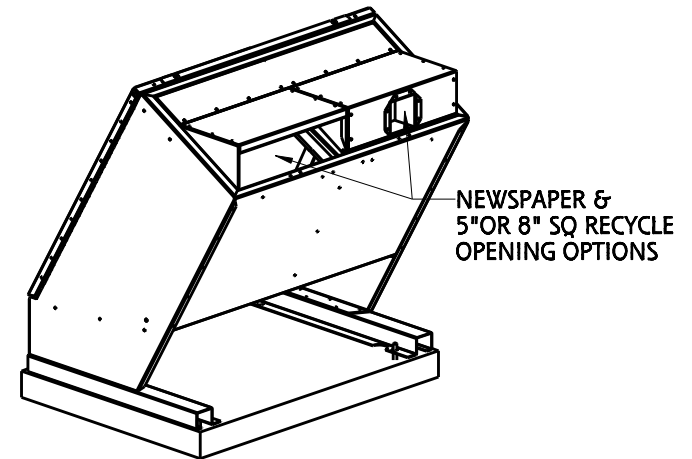

NOTE: ALL DIMENSIONS INCHES (MILLIMETERS)

TRAILER SIZE	QTY	<p>HAUL-ALL EQUIPMENT LTD. reserves proprietary rights on this drawing or any part of the information contained thereon. This drawing shall be considered confidential material and is not to be used for competitive bidding nor for use in any procurements other than from Haul-All Equipment Ltd.</p> 	NAME HBIIS PAPER/RECYCLE CONTAINER		
8-1/2ft x 45ft Long	30		PART NUMBER	SP-HBIIS-YU	DRAWN BY PS
8-1/2ft x 53ft Long	36		DATE	AUGUST 18, 2016	REVISION 1
B-Train	36				
Double Decker Van 8-1/2ft x 48ft	64				