

| FEATURE      | DESCRIPTION                                | SPECIFICATION                         |
|--------------|--------------------------------------------|---------------------------------------|
| Capacity     | Tilt Out Bag Cages                         | 9-1/2 cu.ft. 70 US Gallons (265L)     |
|              | Poly Bag                                   | 2.5 mil 30 x 38 (760 x 965)           |
| Construction | Housing                                    | 16 Ga. (1.6) Galvanneal or SS Steel   |
|              | Lid                                        | 16 Ga. (1.6) Galvanneal or SS Steel   |
|              | Floor                                      | 12 Ga. (2.6) Galvanneal or SS Steel   |
|              | Bottom Hinged User Doors                   | 14 Ga. (1.9) Galvanneal or SS Steel   |
|              | Side Hinged Unloading Doors                | 14 Ga. (1.9) Galvanneal or SS Steel   |
|              | Hinges and Latches                         | Stainless Steel                       |
|              | Paint                                      | Powder Coat                           |
| Weights      | Sentinal 70 Container                      | 285lbs (130kg)                        |
|              | (Optional) Pre-Cast Mounting Pad (OB-1703) | 540lbs (245kg) 48x32x4 (1220x815x102) |

ALL SPECIFICATIONS SUBJECT TO CHANGE WITHOUT NOTICE

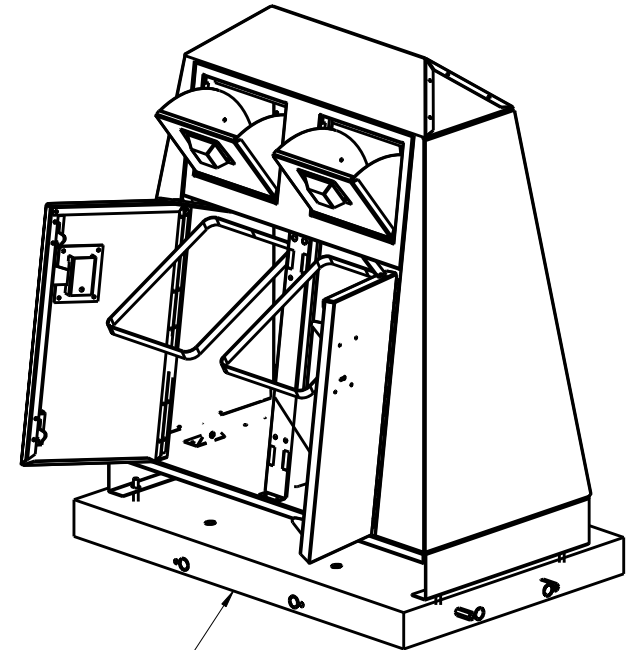

MOUNTING PAD (OPTIONAL)

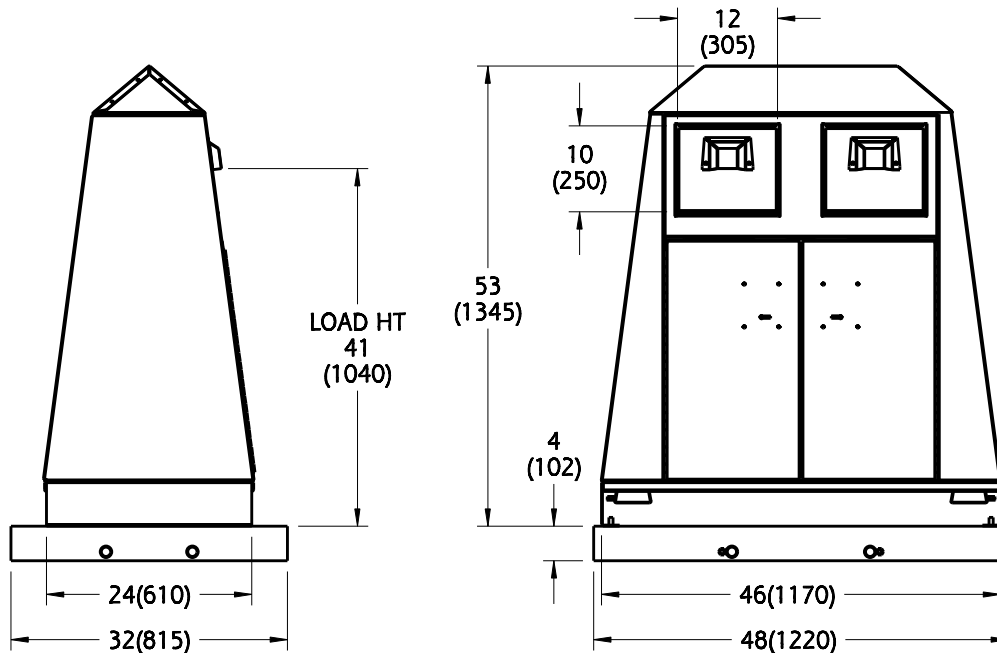
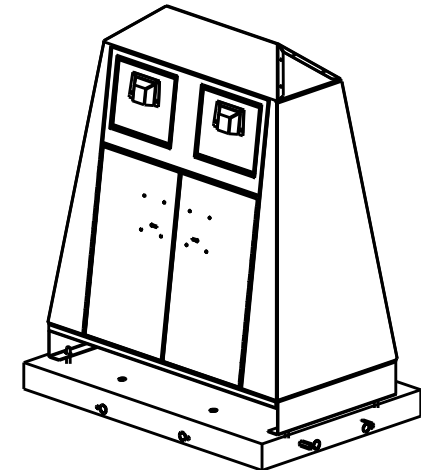

NOTE: ALL DIMENSIONS INCHES (MILLIMETERS)

| TRAILER SIZE                     | QTY | <p>HAUL-ALL EQUIPMENT LTD. reserves proprietary rights on this drawing or any part of the information contained thereon. This drawing shall be considered confidential material and is not to be used for competitive bidding nor for use in any procurements other than from Haul-All Equipment Ltd.</p>  | NAME                  |                 |          |    |
|----------------------------------|-----|-------------------------------------------------------------------------------------------------------------------------------------------------------------------------------------------------------------------------------------------------------------------------------------------------------------------------------------------------------------------------------------------------|-----------------------|-----------------|----------|----|
| 8-1/2ft x 45ft                   | 33  |                                                                                                                                                                                                                                                                                                                                                                                                 | SENTINAL 70 CONTAINER |                 |          |    |
| 8-1/2ft x 53ft                   | 39  |                                                                                                                                                                                                                                                                                                                                                                                                 | PART NUMBER           | SP-OB70         | DRAWN BY | PS |
| B-Train 8-1/2ft x 28ft & 32ft    | 45  |                                                                                                                                                                                                                                                                                                                                                                                                 | DATE                  | AUGUST 25, 2016 | REVISION | 1  |
| Double Decker Van 8-1/2ft x 48ft | 72  |                                                                                                                                                                                                                                                                                                                                                                                                 |                       |                 |          |    |

| FEATURE      | DESCRIPTION                                | SPECIFICATION                         |
|--------------|--------------------------------------------|---------------------------------------|
| Capacity     | Tilt Out Bag Cages                         | 9-1/2 cu.ft. 70 US Gallons (265L)     |
|              | Poly Bag                                   | 2.5 mil 30 x 38 (760 x 965)           |
| Construction | Housing                                    | 16 Ga. (1.6) Galvanneal or SS Steel   |
|              | Lid                                        | 16 Ga. (1.6) Galvanneal or SS Steel   |
|              | Floor                                      | 12 Ga. (2.6) Galvanneal or SS Steel   |
|              | Bottom Hinged User Doors                   | 14 Ga. (1.9) Galvanneal or SS Steel   |
|              | Side Hinged Unloading Doors                | 14 Ga. (1.9) Galvanneal or SS Steel   |
|              | Hinges and Latches                         | Stainless Steel                       |
|              | Paint                                      | Powder Coat                           |
| Weights      | Sentinal 70 Container                      | 285lbs (130kg)                        |
|              | (Optional) Pre-Cast Mounting Pad (OB-1703) | 540lbs (245kg) 48x32x4 (1220x815x102) |

ALL SPECIFICATIONS SUBJECT TO CHANGE WITHOUT NOTICE

5" DIAMETER  
RESTRICTOR PLATE

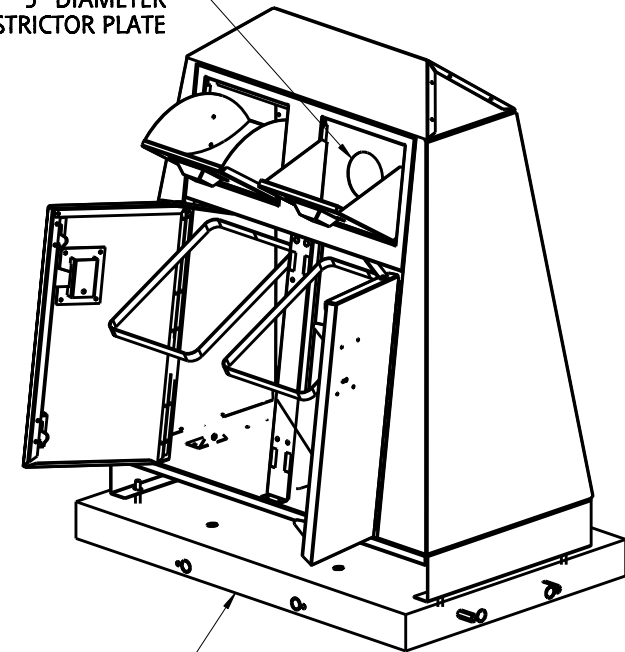

MOUNTING PAD  
(OPTIONAL)

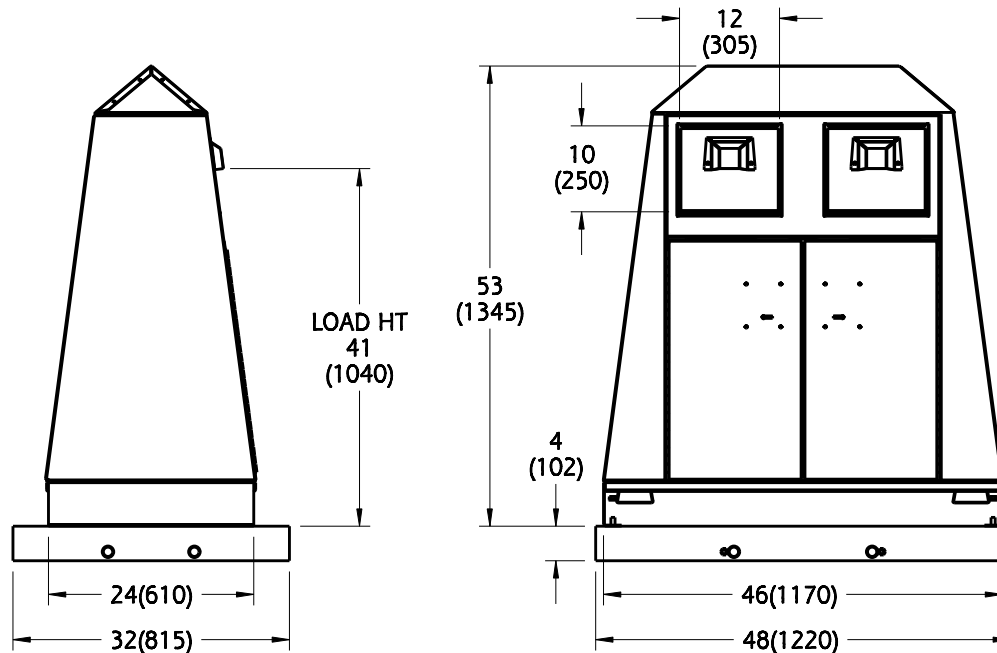
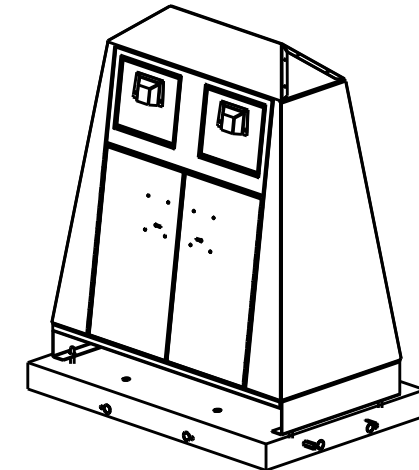

NOTE: ALL DIMENSIONS INCHES (MILLIMETERS)

| TRAILER SIZE                     | QTY | HAUL-ALL EQUIPMENT LTD. reserves proprietary rights on this drawing or any part of the information contained thereon. This drawing shall be considered confidential material and is not to be used for competitive bidding nor for use in any procurements other than from Haul-All Equipment Ltd. | NAME                  |                 |                |
|----------------------------------|-----|----------------------------------------------------------------------------------------------------------------------------------------------------------------------------------------------------------------------------------------------------------------------------------------------------|-----------------------|-----------------|----------------|
| 8-1/2ft x 45ft                   | 33  |                                                                                                                                                                                                                                                                                                    | SENTINAL 70 CONTAINER |                 |                |
| 8-1/2ft x 53ft                   | 39  |                                                                                                                                                                                                                                                                                                    | PART NUMBER           | SP-OB70R        | DRAWN BY<br>PS |
| B-Train 8-1/2ft x 28ft & 32ft    | 45  |                                                                                                                                                                                                                                                                                                    | DATE                  | AUGUST 25, 2016 | REVISION<br>1  |
| Double Decker Van 8-1/2ft x 48ft | 72  |                                                                                                                                                                                                               |                       |                 |                |